



StowAway Table Installation Guide



FOLLOW INSTRUCTIONS CAREFULLY TO AVOID ANY DAMAGE TO YOUR SMARTCAP PRODUCT OR YOUR VEHICLE

IF YOU HAVE QUESTIONS OR CONCERNS, PLEASE DO NOT HESITATE TO CONTACT US AT:

SUPPORT.NA@RSISMARTCAP.COM - NORTH AMERICA

SUPPORT.SA@SMARTCAP.COM - INTERNATIONAL/SOUTH AFRICA



COMPONENTS

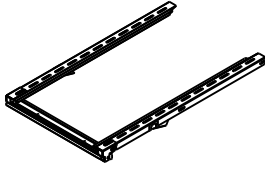

1X TABLE
BRACKET

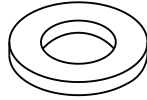

8X M8 X 20
FENDER WASHERS

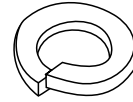

8X M8
SPRING WASHER

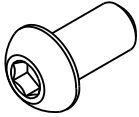

8X M8 X 20
BUTTON HEAD SCREWS

REQUIRED TOOLS

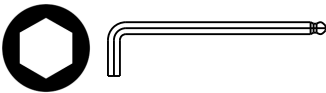

**ALLEN KEY SET
4MM**

WARNING

2



- ONLY USE THE RECOMMENDED TOOLS AS INDICATED IN THE INSTALLATION GUIDE ABOVE.
- ONLY USE THE HARDWARE PROVIDED IN THE FITMENT KIT OUTLINED ABOVE.
- HANDLE ALL RSI COMPONENTS WITH CARE UPON UNPACKING.
- IT IS RECOMMENDED THAT THE MINIMUM OF TWO PEOPLE LIFT THE RSI PRODUCT.
- NEVER USE ACETONE ON PAINTWORK

FITMENT OF THE STOWAWAY TABLE

STEP ONE

1. UNPACK ALL COMPONENTS & THE HARDWARE KIT FROM PACKAGING; ENSURE THAT EVERYTHING IS ACCOUNTED FOR AS INDICATED ON PAGE BEFORE.
2. PLACE ALL COMPONENTS DOWN ON A PROTECTED SURFACE TO PREVENT DAMAGE.

STEP TWO

1. PICK UP THE ROOF MOUNTED TABLE BRACKET AND POSITION IN PLACE, A MINIMUM OF 2 PEOPLE ARE RECOMMENDED FOR THE INSTALLATION.
2. MAKE SURE THE DROP DOWN SIDE IS FACING THE REAR OF THE SMARTCAP.
3. USE CAUTION WHEN WORKING TO AVOID ANY DAMAGES.

DROP DOWN TO FACE REAR DOOR

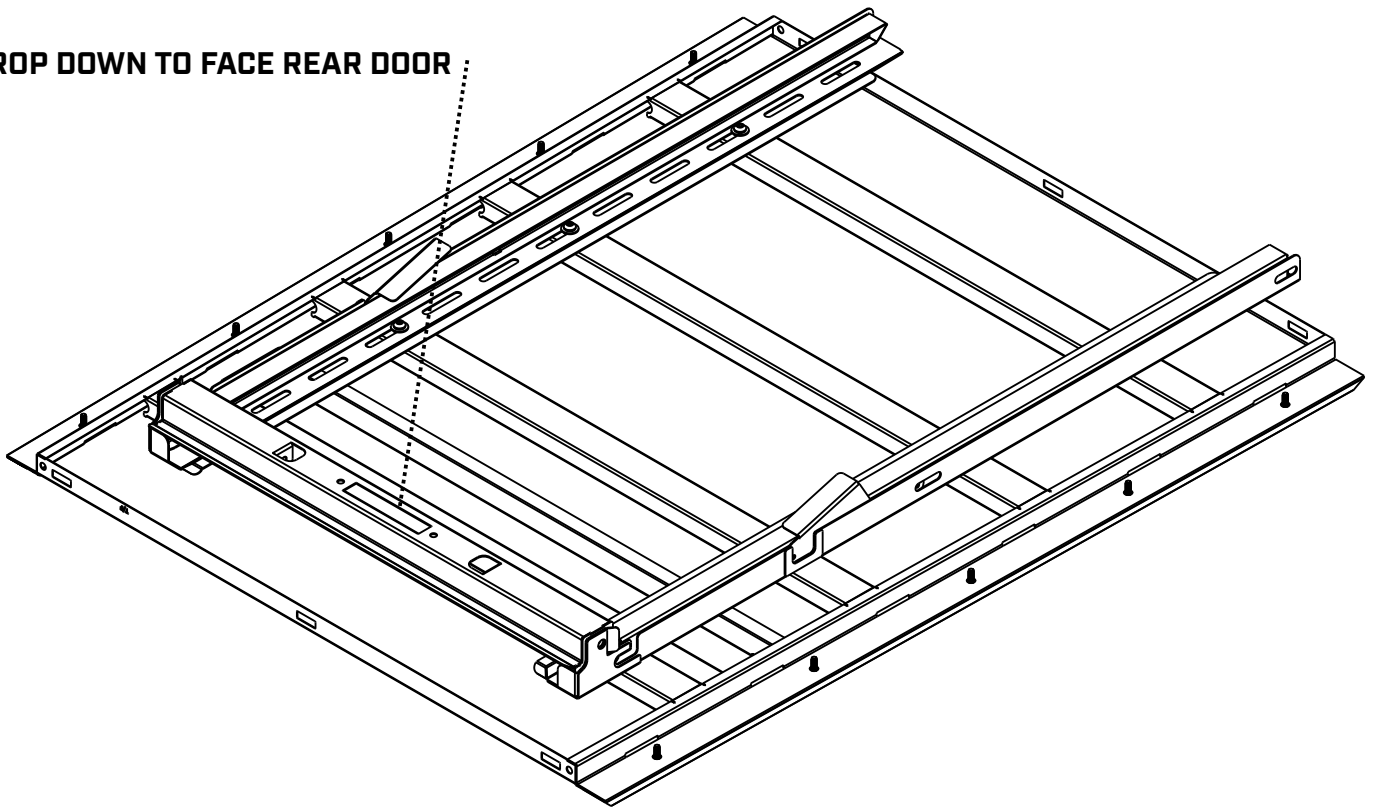

STEP THREE

1. ALIGN THE FIRST SLOT OF THE TABLE BRACKET WITH THE FIRST RIV NUT INSTALLED IN THE ROOF OF THE SMARTCAP.
2. USE THE HARDWARE DEPICTED BELOW TO FASTEN THE ROOF MOUNTED TABLE IN PLACE.
3. HAND FASTEN THE HARDWARE FIRST.
4. ONCE THE FIRST SLOT IS HAND FASTENED WITH ITS HARDWARE, HAND FASTEN ALL THE OTHER FASTENING POINTS THAT LINE UP.
5. THERE SHOULD BE A TOTAL OF 8 FASTENING POINTS, 4 X LEFT AND 4 X RIGHT.
6. ONCE ALL FASTENING POINTS ARE HAND FASTENED WITH THE DEPICTED HARDWARE, SLIDE THE ROOF MOUNTED TABLE BRACKET AS FAR BACK AS POSSIBLE BEFORE FASTENING THE HARDWARE.[SLIDE TOWARD THE REAR OF THE SMARTCAP.]
7. DO NOT OVER TIGHTEN THE HARDWARE.
8. PLEASE USE CAUTION WHEN WORKING TO AVOID ANY UNNECESSARY FORMS OF DAMAGE.

FITMENT OF THE STOWAWAY TABLE

M8 X 20 FENDER WASHER

M8 SPRING WASHER

M8 X 20 BUTTON HEAD SCREW

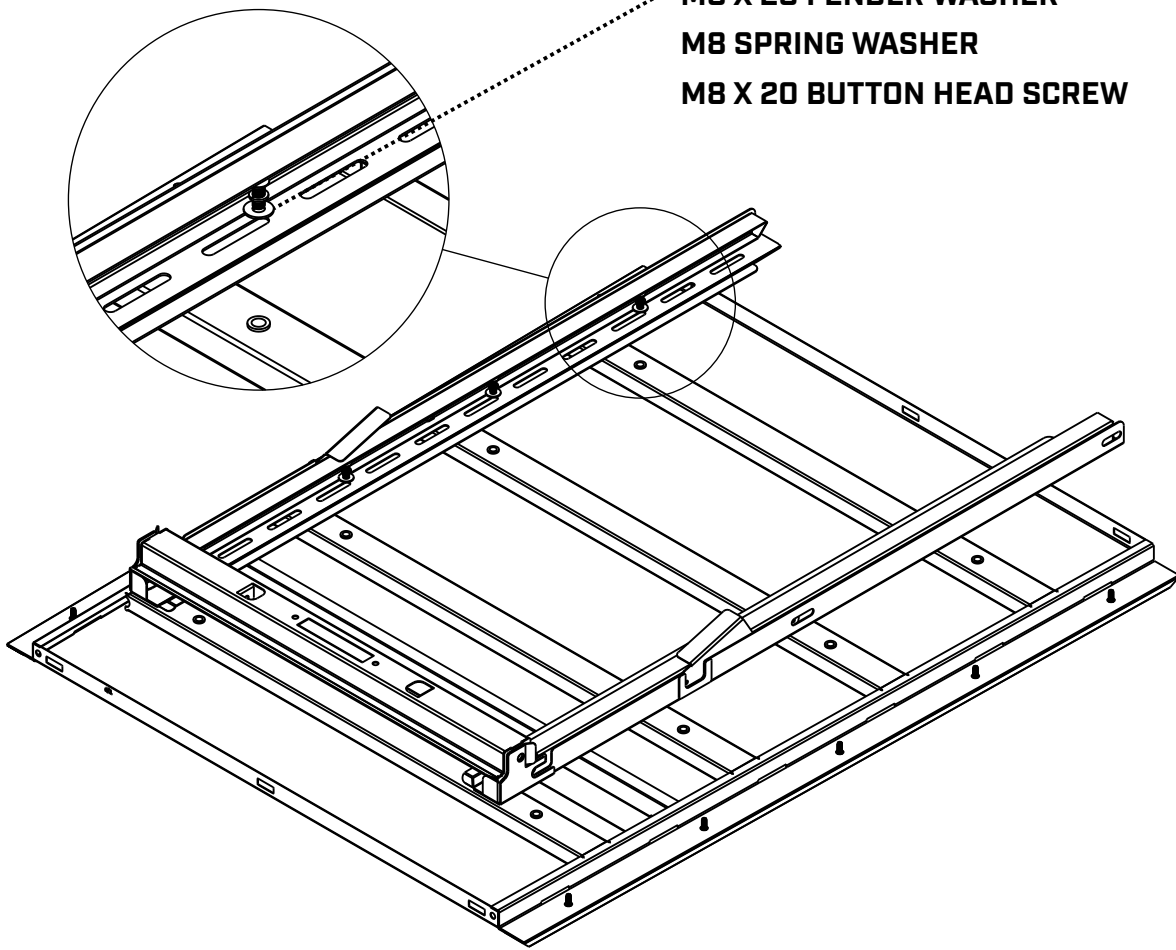

**FIRST SLOT ALIGNED WITH FIRST
RIV NUT ON ROOF PANEL.**

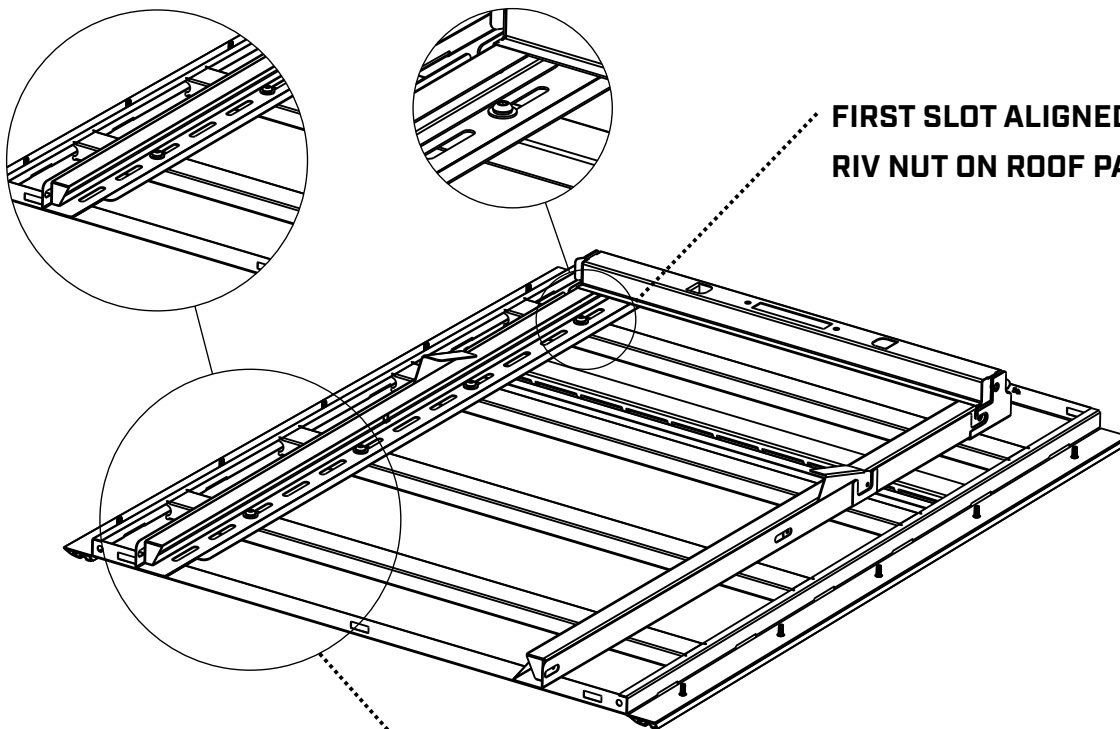

**ALIGN ALL OTHER FASTENING POINTS
AND FASTEN SUFFICIENTLY.**

FITMENT OF THE STOWAWAY TABLE

STEP FOUR

1. ONCE THE ROOF TABLE BRACKET IS SECURED TO THE ROOF OF THE SMARTCAP, SLIDE THE SMARTCAP STOW AWAY TABLE INTO THE ROOF MOUNTED BRACKET.
2. THE FLAT SIDE OF THE TABLE HAS TO BE FACING DOWN. (SEE IMAGE DEPICTED BELOW.)
3. USE CAUTION WHEN SLIDING THE SMARTCAP STOW AWAY TABLE INTO THE ROOF MOUNTED TABLE BRACKET.

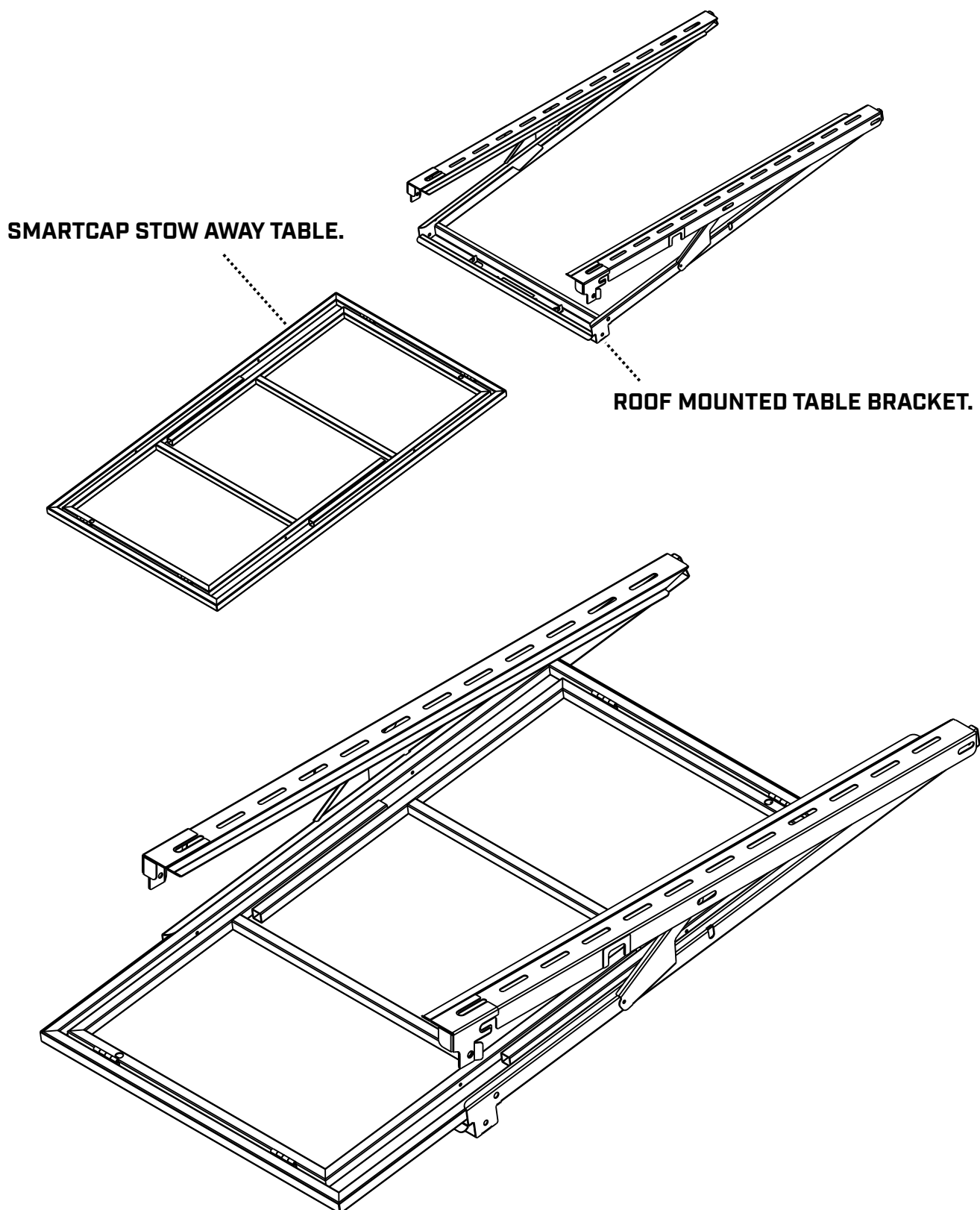

FITMENT OF THE STOWAWAY TABLE

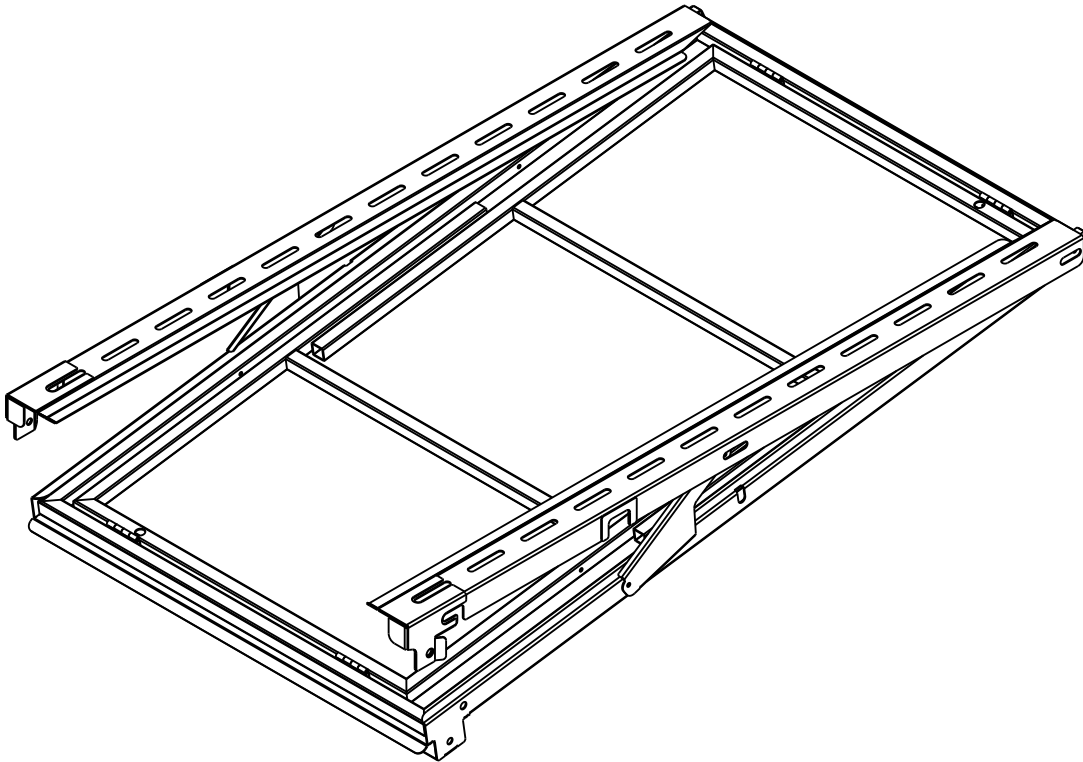

STEP FIVE

1. ONCE THE SMARTCAP STOW AWAY TABLE IS SLID INTO THE ROOF MOUNTED TABLE BRACKET, CLOSE AND LOCK THE TABLE BRACKET INTO ITS CLOSED POSITION.
2. USE CAUTION WHEN CLOSING THE ROOF MOUNTED TABLE BRACKET.

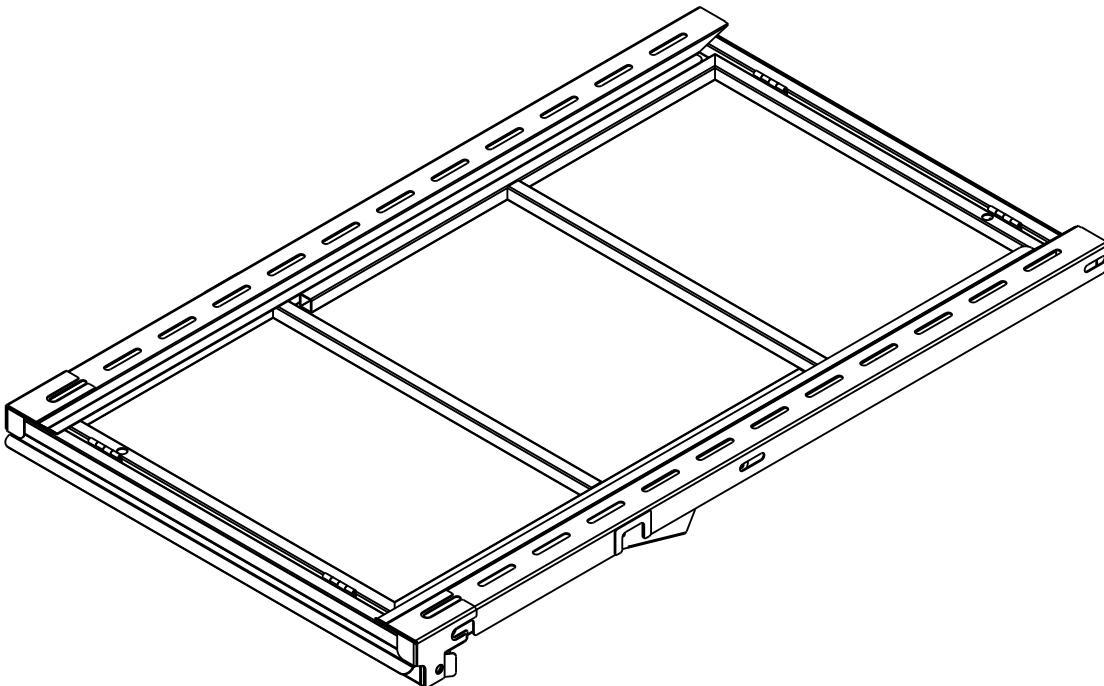

SMARTCAP.COM