

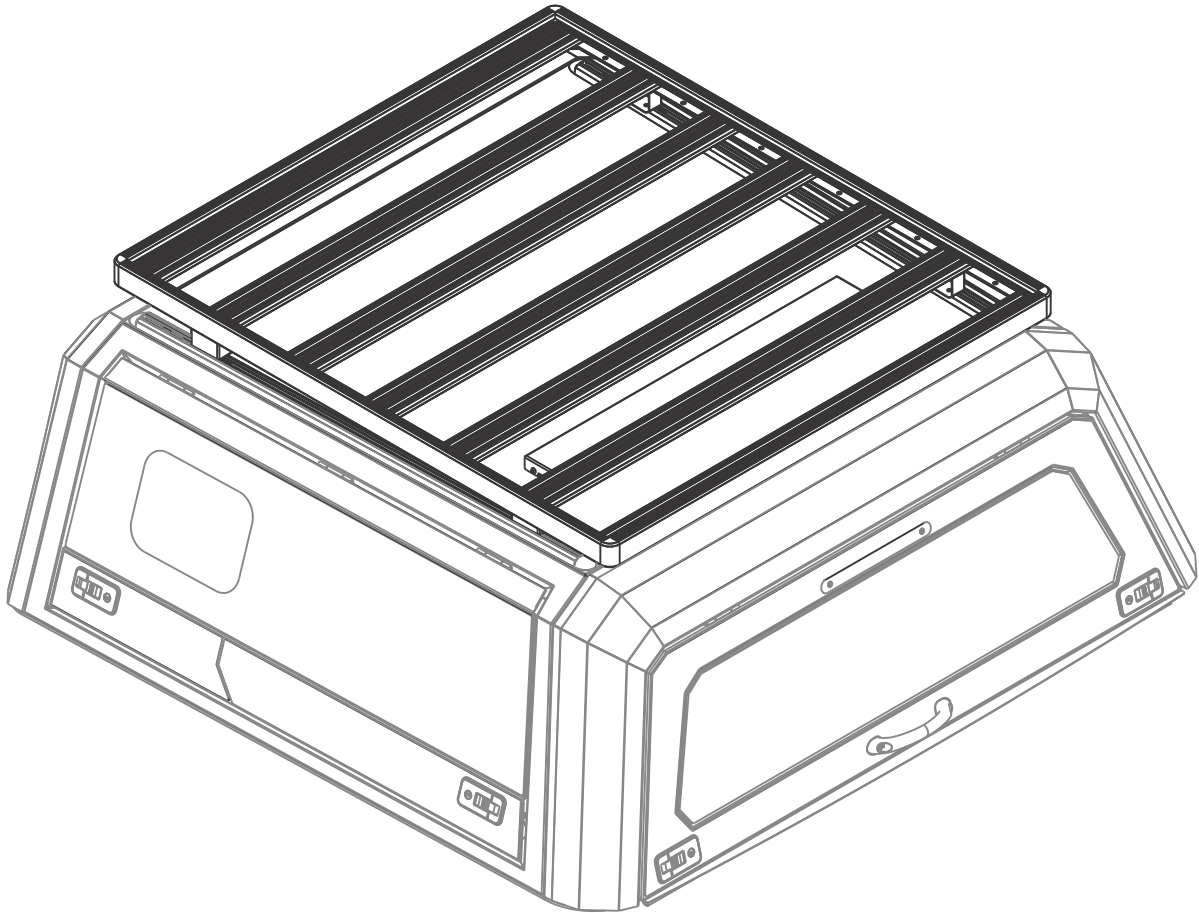

## Platform Rack Installation Guide



**FOLLOW INSTRUCTIONS CAREFULLY TO AVOID ANY DAMAGE TO YOUR SMARTCAP PRODUCT OR YOUR VEHICLE**

**IF YOU HAVE QUESTIONS OR CONCERNS, PLEASE DO NOT HESITATE TO CONTACT US AT:**

SUPPORT.NA@RSISMARTCAP.COM - NORTH AMERICA

[SUPPORT.SA@SMARTCAP.COM](mailto:SUPPORT.SA@SMARTCAP.COM) - INTERNATIONAL/SOUTH AFRICA



# TABLE OF CONTENTS

REQUIRED TOOLS .....	2
HARDWARE .....	3
ASSEMBLY INSTRUCTIONS .....	4-7
FITMENT INSTRUCTIONS .....	8
SUPPORT DETAILS .....	8

## REQUIRED TOOLS

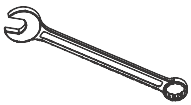

Spanner Set  
13mm Flat

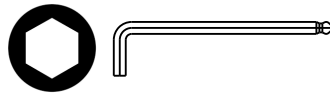

Allen Key Set  
5mm & 2.5mm



Tape  
Measure



### WARNING

- USE ONLY THE TOOLS RECOMMENDED IN THIS GUIDE
- USE ONLY THE HARDWARE THAT HAS BEEN PROVIDED
- HANDLE ALL COMPONENTS WITH CARE
- NEVER USE ACETONE ON THE PAINTWORK
- AVOID PINCHING/SQUASHING HANDS

# HARDWARE

## ASSEMBLY

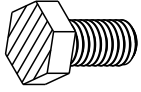

**8X** M8 X 16  
MACHINE SET SCREWS



**8X** M8  
NYLOC NUTS

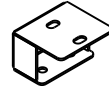

**4X** MOUNTING  
FEET

**ST**

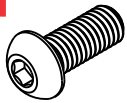

**16X** M8 X 20 BUTTON  
HEAD SCREW

**SB**



**14X** M8 X 20 BUTTON  
HEAD SCREW

## FITMENT

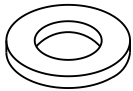

**16X** M8  
FLAT WASHERS

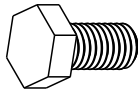

**8X** M8 X 16  
SET SCREWS

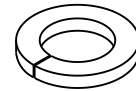

**8X** M8  
SPRING WASHER



**8X** M8  
WELD NUTS

**NB: Please Note That.  
SB Platform Racks Utilises 5 X Load Bars.  
ST Platform Rack Utilises 6 X Load Bars.**

# ASSEMBLY OF THE SMARTCAP ACCESSORY

## STEP ONE

1. LAY DOWN SIDE RAIL UPSIDE DOWN

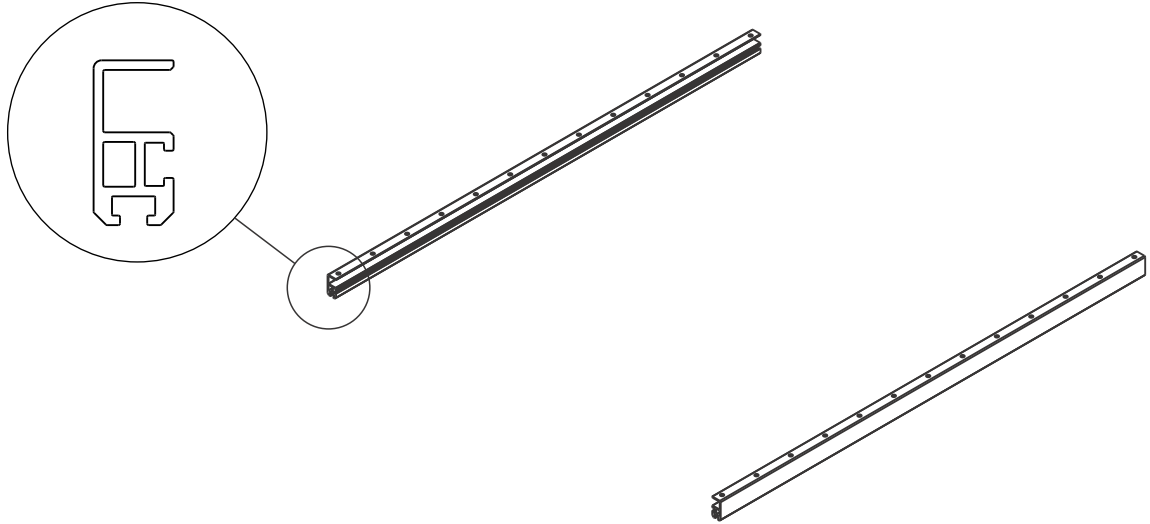

## STEP TWO

1. FIT LOAD BARS TO SIDE RAILS, ENSURE TO START WITH THE 3RD HOLE INBOARD FROM THE SIDE RAILS.
2. TIGHTEN BUTTON HEAD SCREW USING 5MM ALLEN KEY
3. REPEAT PROCESS ON OPPOSITE SIDE.

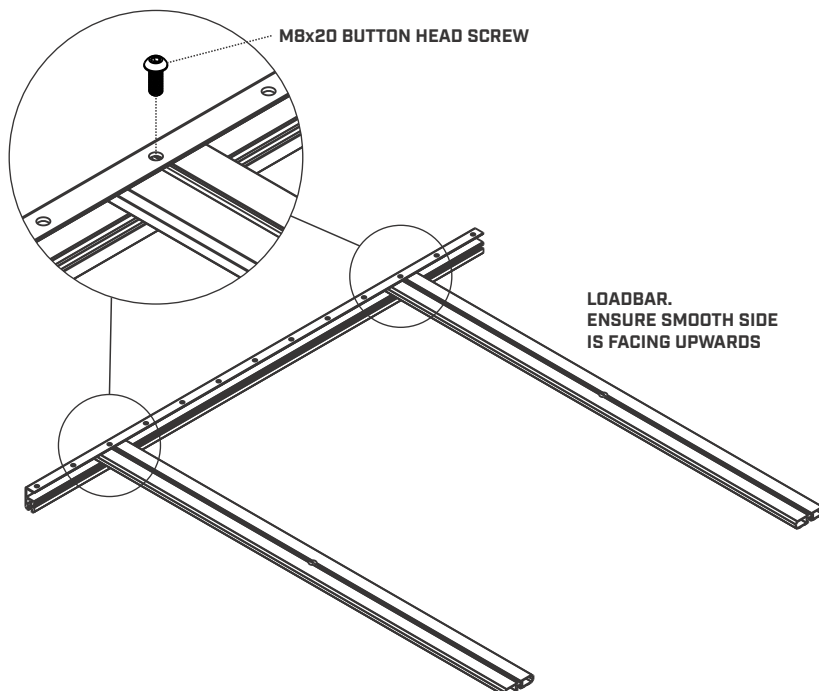

# ASSEMBLY OF THE SMARTCAP ACCESSORY

## STEP THREE

1. FIT THE LOADBARS AS DEPICTED BY THE IMAGE BELOW.  
[FOR SB PLATFORM RACKS, ASSEMBLE 5 LOAD BARS]  
[FOR ST PLATFORM RACKS, ASSEMBLE 6 LOAD BARS]

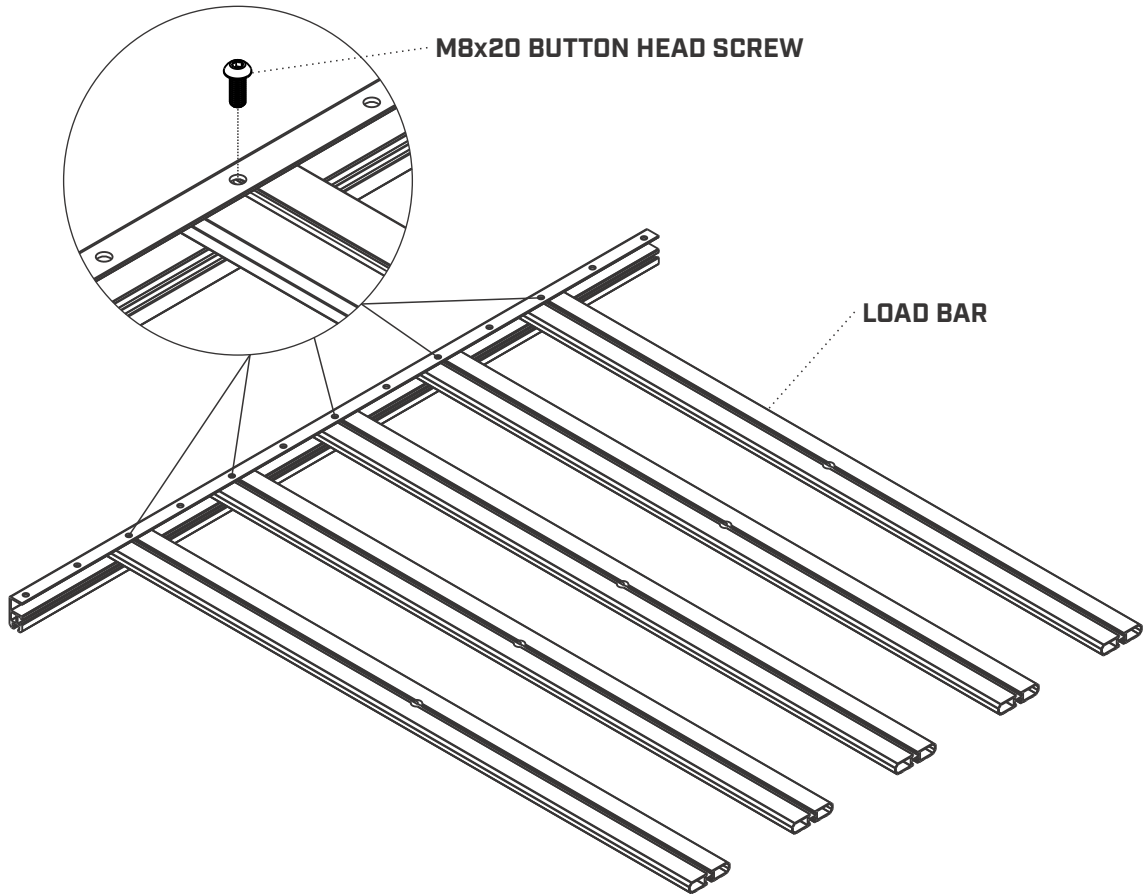

REPEAT PROCESS ON OPPOSITE SIDE.

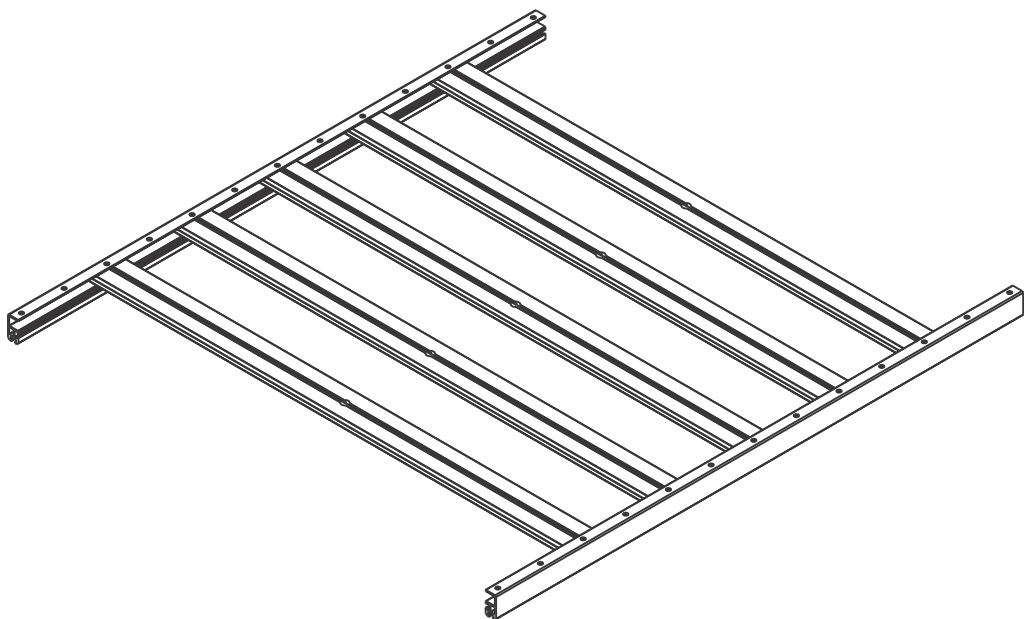

# ASSEMBLY OF THE SMARTCAP ACCESSORY

## STEP FOUR

1. FIT THE ENDS ON AND FASTEN IN PLACE.

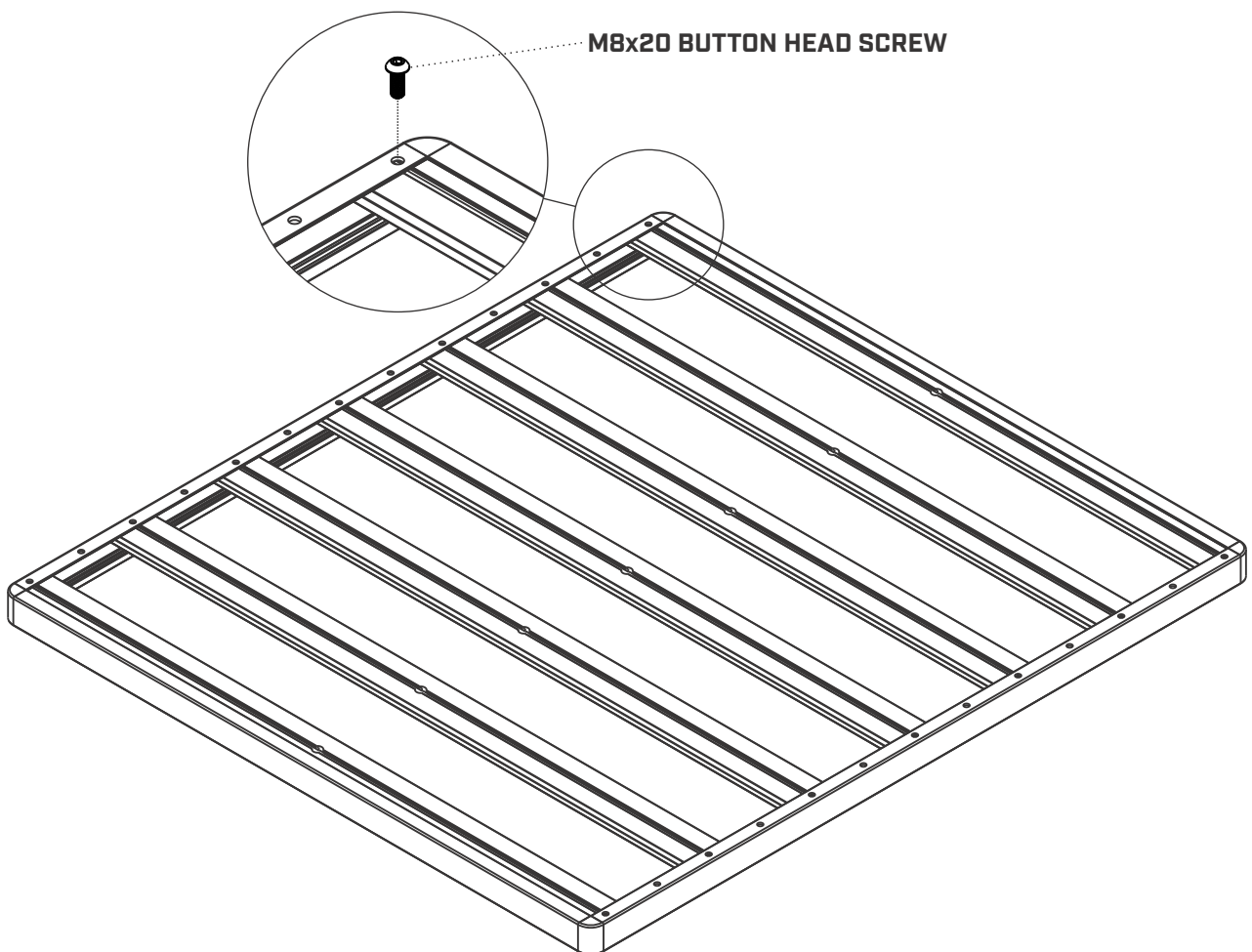
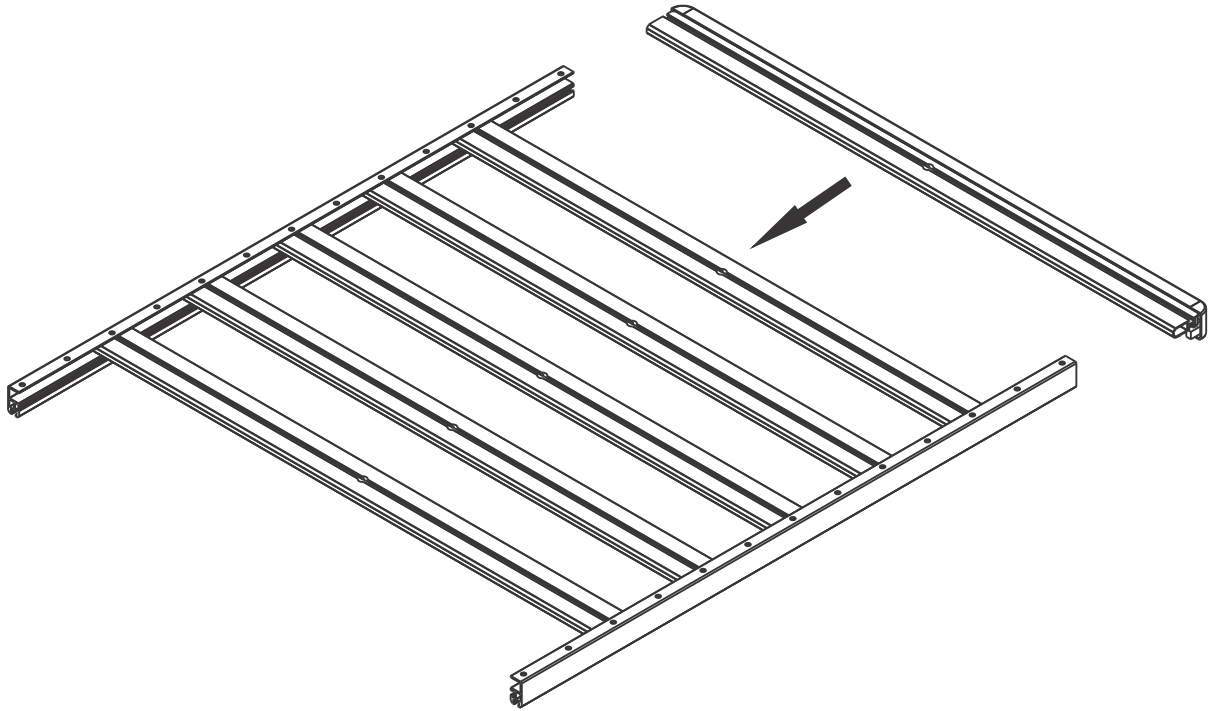

# ASSEMBLY OF THE SMARTCAP ACCESSORY

## STEP FIVE

1. FIT THE MACHINED BOLTS INTO THE BOTTOM SLOT OF THE LOADBAR AS DEPICTED IN THE IMAGE BELOW.
2. HAND FASTEN THE MOUNTING FEET ONTO THE PLATFORM RACK

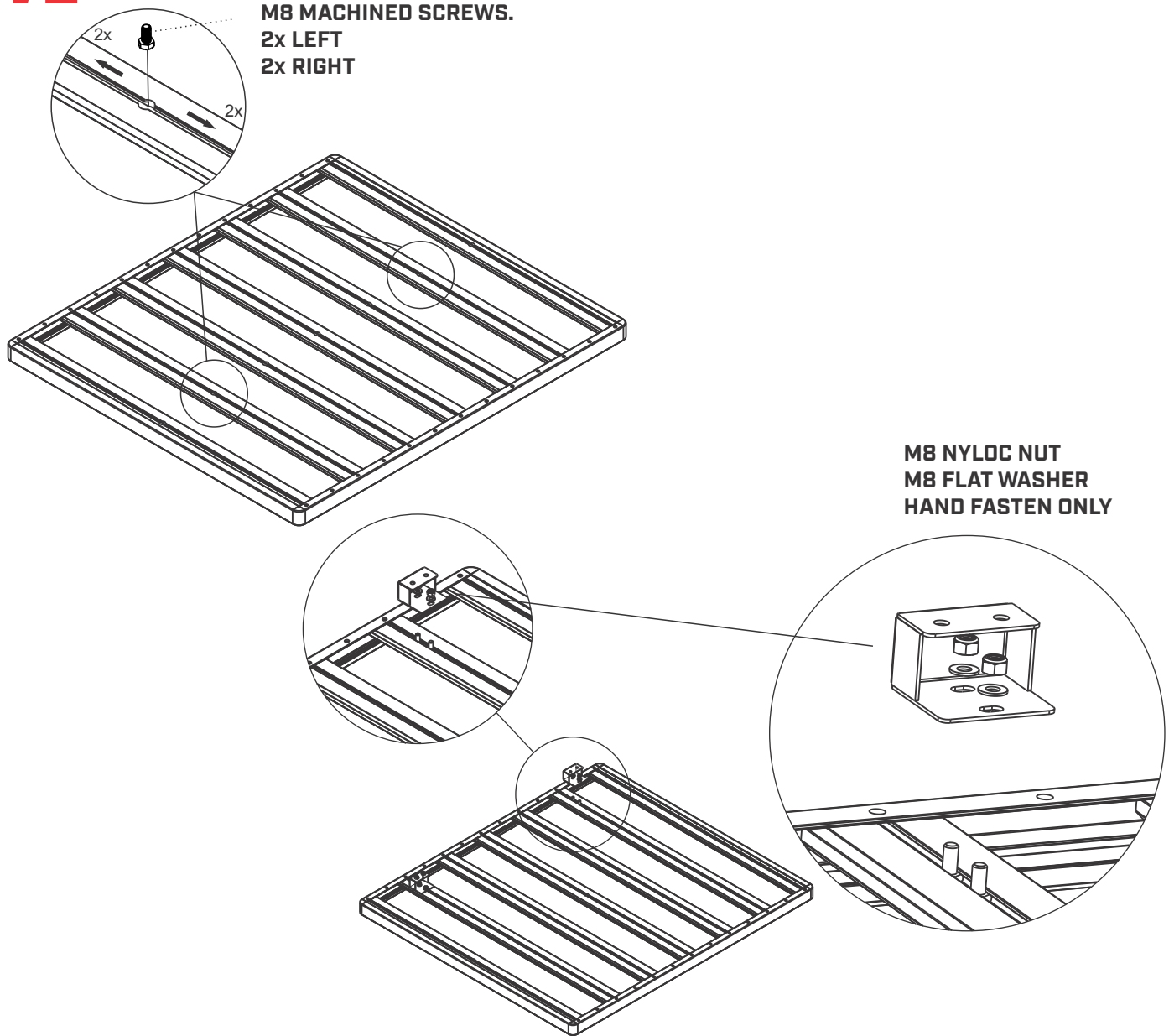

## STEP SIX

1. FIT THE HARDWARE ONTO THE MOUNTING FEET.

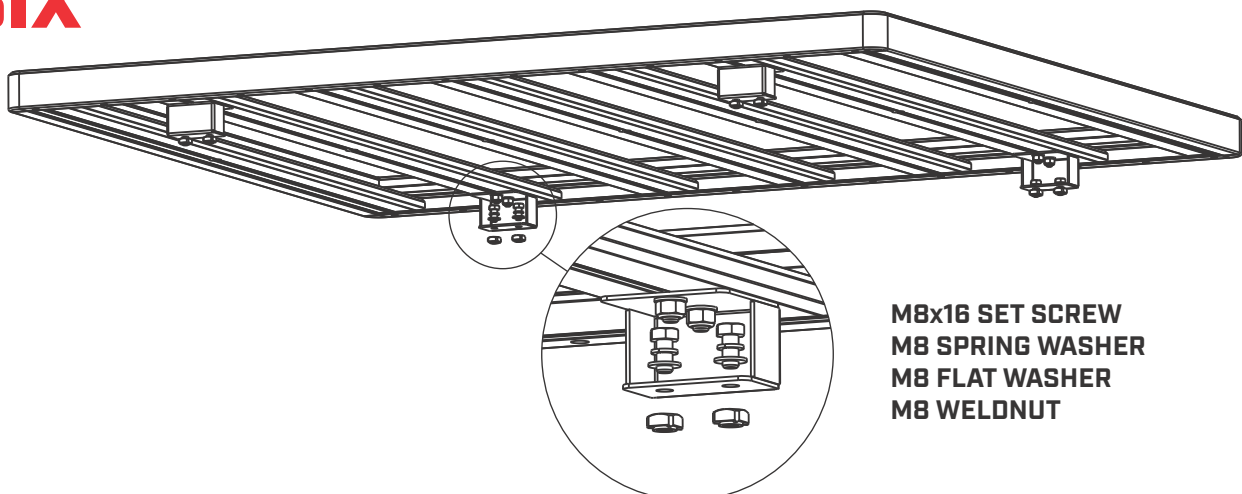

# FITMENT OF THE SMARTCAP ACCESSORY

## STEP SEVEN

1. REMOVE REAR ROOF END CAPS USING 2.5MM ALLEN KEY.
2. SLIDE THE WELDNUTS INTO THE RAIL.
3. DO THIS TO BOTH FRONT AND REAR.
4. CENTRALISE PLATFORM RACK ON ROOF RAILS USING A MEASURING TAPE.
5. TIGHTEN ALL HARDWARE USING 13MM SPANNER.
6. RE-FIT ROOF END CAPS.

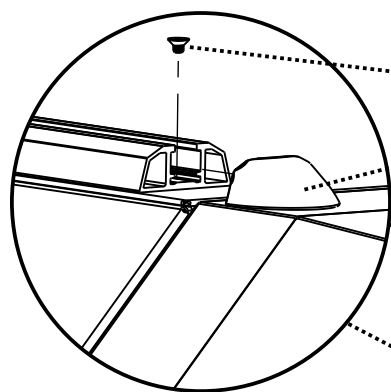

CSK SCREW SUPPLIED WITH ROOF RAIL

ROOF RAIL ENDCAP

