

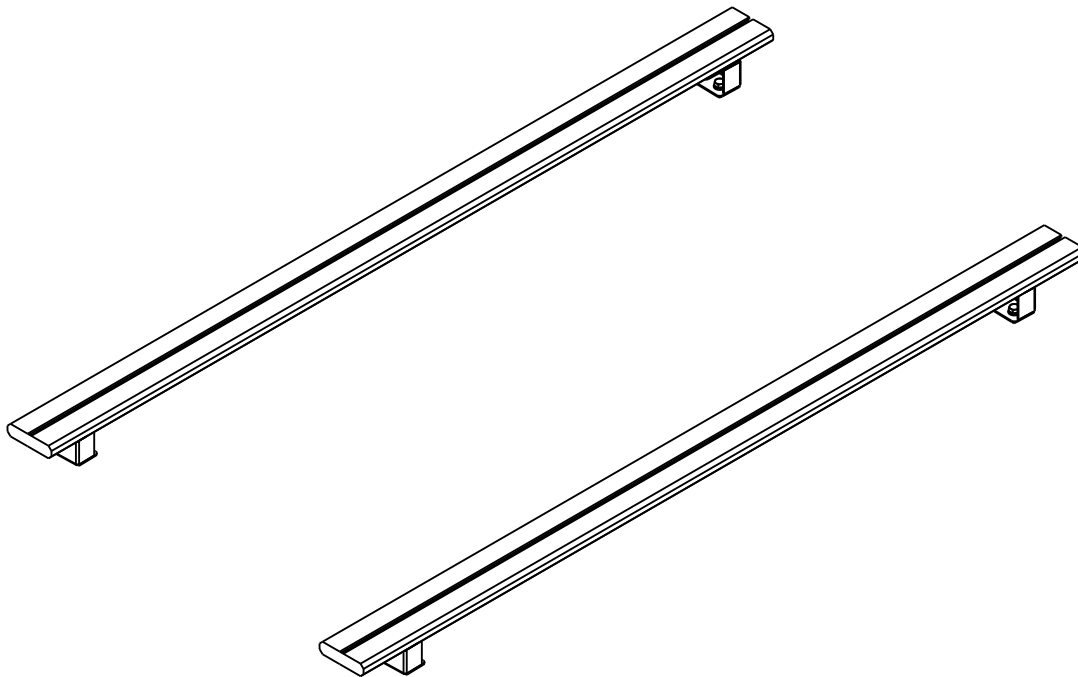

Load Bar Installation Guide



FOLLOW INSTRUCTIONS CAREFULLY TO AVOID ANY DAMAGE TO YOUR SMARTCAP PRODUCT OR YOUR VEHICLE

IF YOU HAVE QUESTIONS OR CONCERNS, PLEASE DO NOT HESITATE TO CONTACT US AT:

SUPPORT.NA@RSISMARTCAP.COM - NORTH AMERICA

SUPPORT.SA@SMARTCAP.COM - INTERNATIONAL/SOUTH AFRICA



COMPONENTS

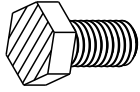

8X M8 X 16
MACHINE SET SCREWS

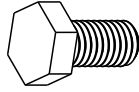

8X M8 X 16
SET SCREWS

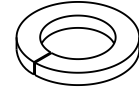

8X M8
SPRING WASHER

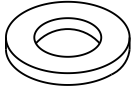

16X M8
FLAT WASHERS



8X M8
NYLOC NUTS

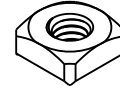

8X M8
WELD NUTS

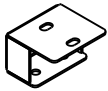

4X MOUNTING
FEET



2X LOAD BARS

REQUIRED TOOLS

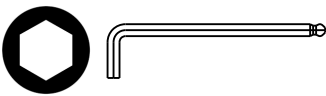

ALLEN KEY SET

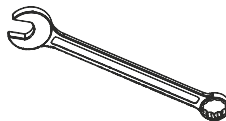

COMBINATION WRENCH
13mm FLAT



MEASURING TAPE

WARNING



- ONLY USE THE RECOMMENDED TOOLS AS INDICATED IN THE INSTALLATION GUIDE ABOVE.
- ONLY USE THE HARDWARE PROVIDED IN THE FITMENT KIT OUTLINED ABOVE.
- HANDLE ALL RSI COMPONENTS WITH CARE UPON UNPACKING.
- IT IS RECOMMENDED THAT THE MINIMUM OF TWO PEOPLE LIFT THE RSI PRODUCT.
- NEVER USE ACETONE ON PAINTWORK

STEP ONE

1. REMOVE THE ENDCAPS THAT ARE FASTENED TO THE ENDS OF THE SMARTCAP ROOF RAILS [SEE FIGURE 1]
2. DO NOT MISPLACE THE ENDCAPS OR FASTENERS AS THEY NEED TO BE RE-FITTED.

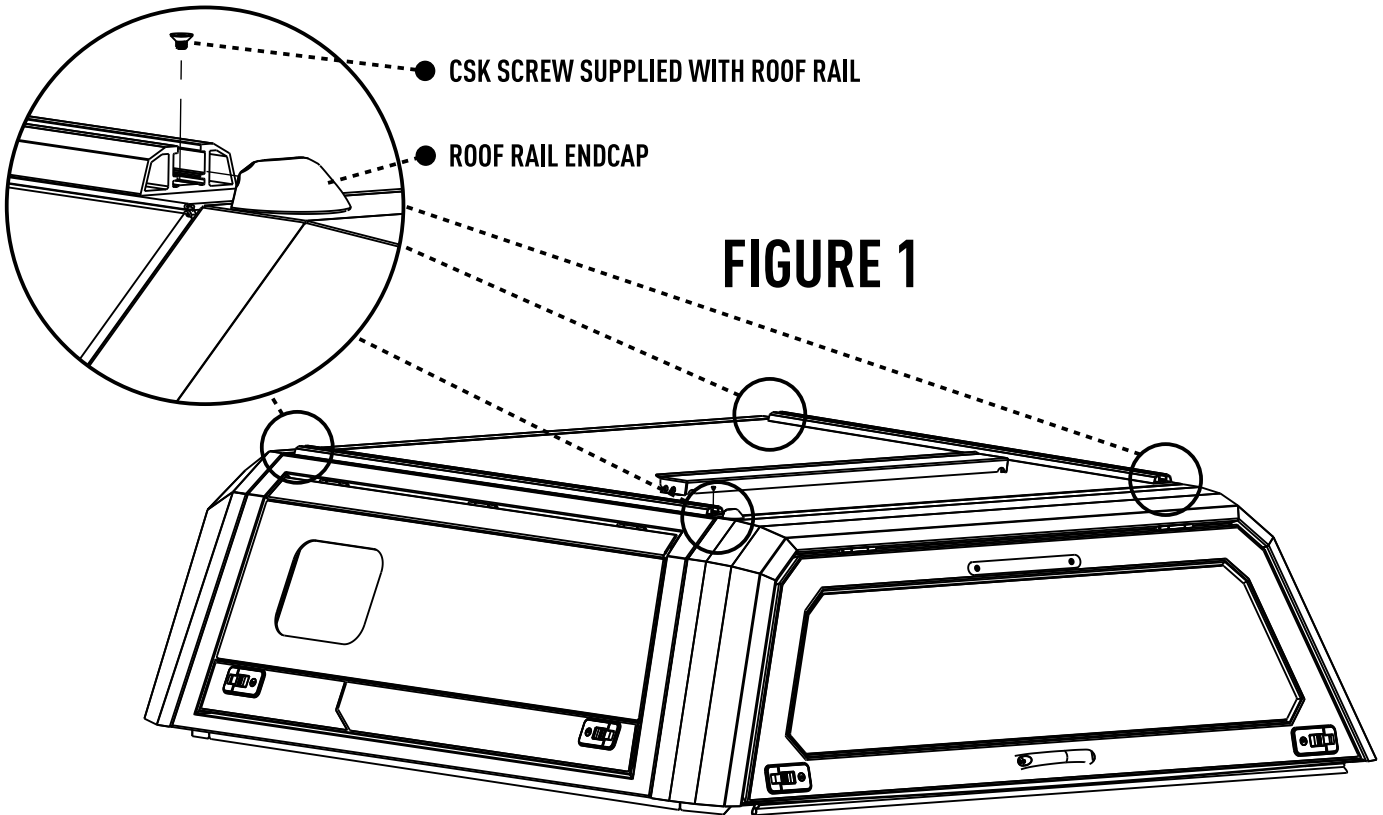

FITMENT OF THE SMARTCAP ACCESSORY

STEP TWO

1. SLIDE THE M8 MACHINED SET SCREWS INTO THE BOTTOM CHANNEL OF THE LOADBARS, THERE SHOULD BE AN OPENING IN THE CENTRE TO SLIDE THE M8 MACHINED SCREWS INTO POSITION [SEE FIGURE 2]
2. PLEASE NOTE THERE HAS TO BE 2 X M8 MACHINED SET SCREWS ON EITHER SIDE.
3. FOLLOW THIS PROCESS FOR BOTH LOADBARS.

FIGURE 2

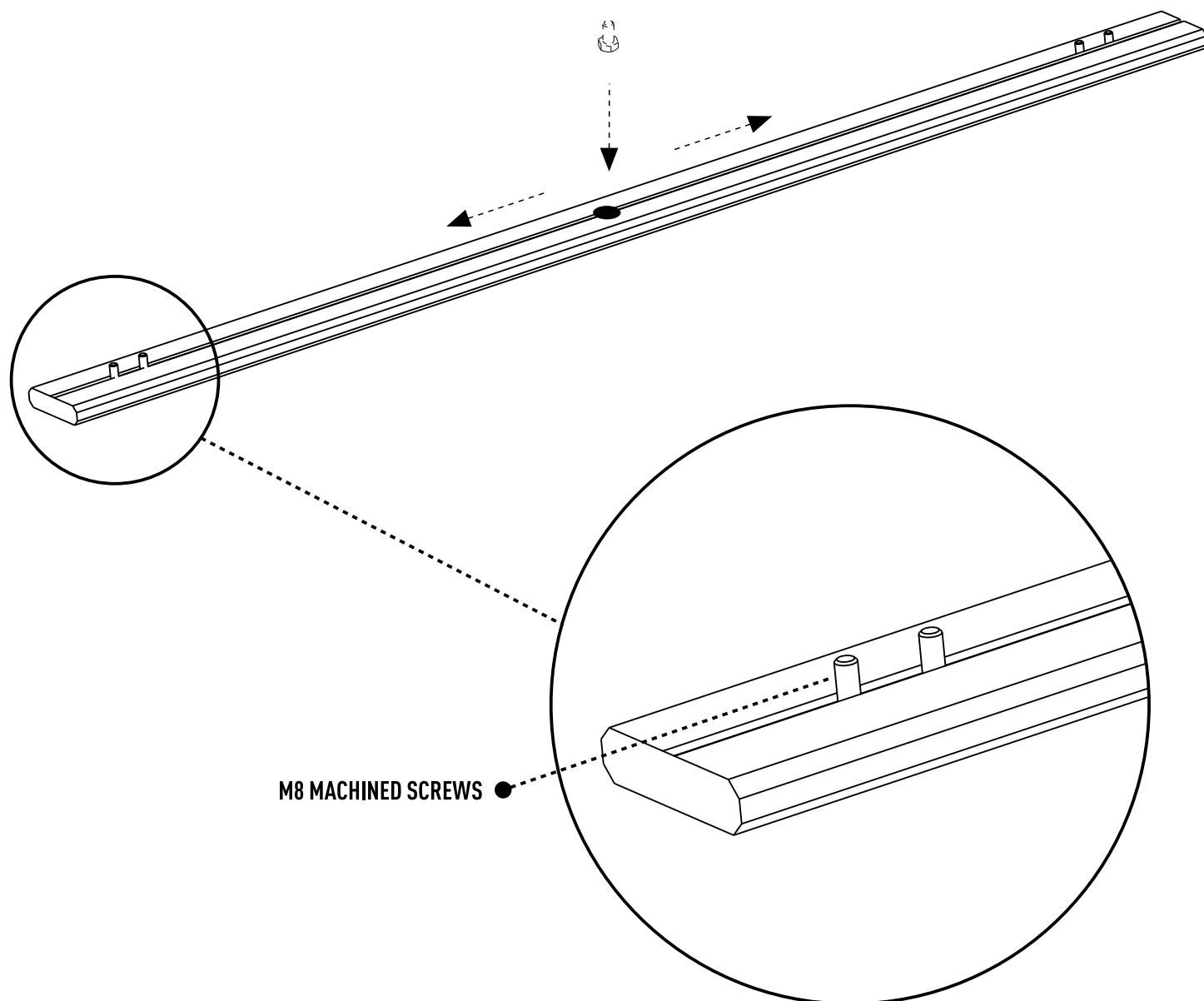

4

REPEAT ON OPPOSITE SIDE

FITMENT OF THE SMARTCAP ACCESSORY

STEP THREE

1. ONCE THE MACHINED SET SCREWS ARE IN PLACE (4 PER LOAD BAR, 2 ON EITHER SIDE) PLACE THE MOUNTING FOOT INTO POSITION AND HAND FASTEN AT THIS POINT.
2. ONLY USE THE HARDWARE PROVIDED AS SHOWN IN FIGURE 3.
3. FOLLOW THIS PROCESS FOR BOTH LOADBARS.

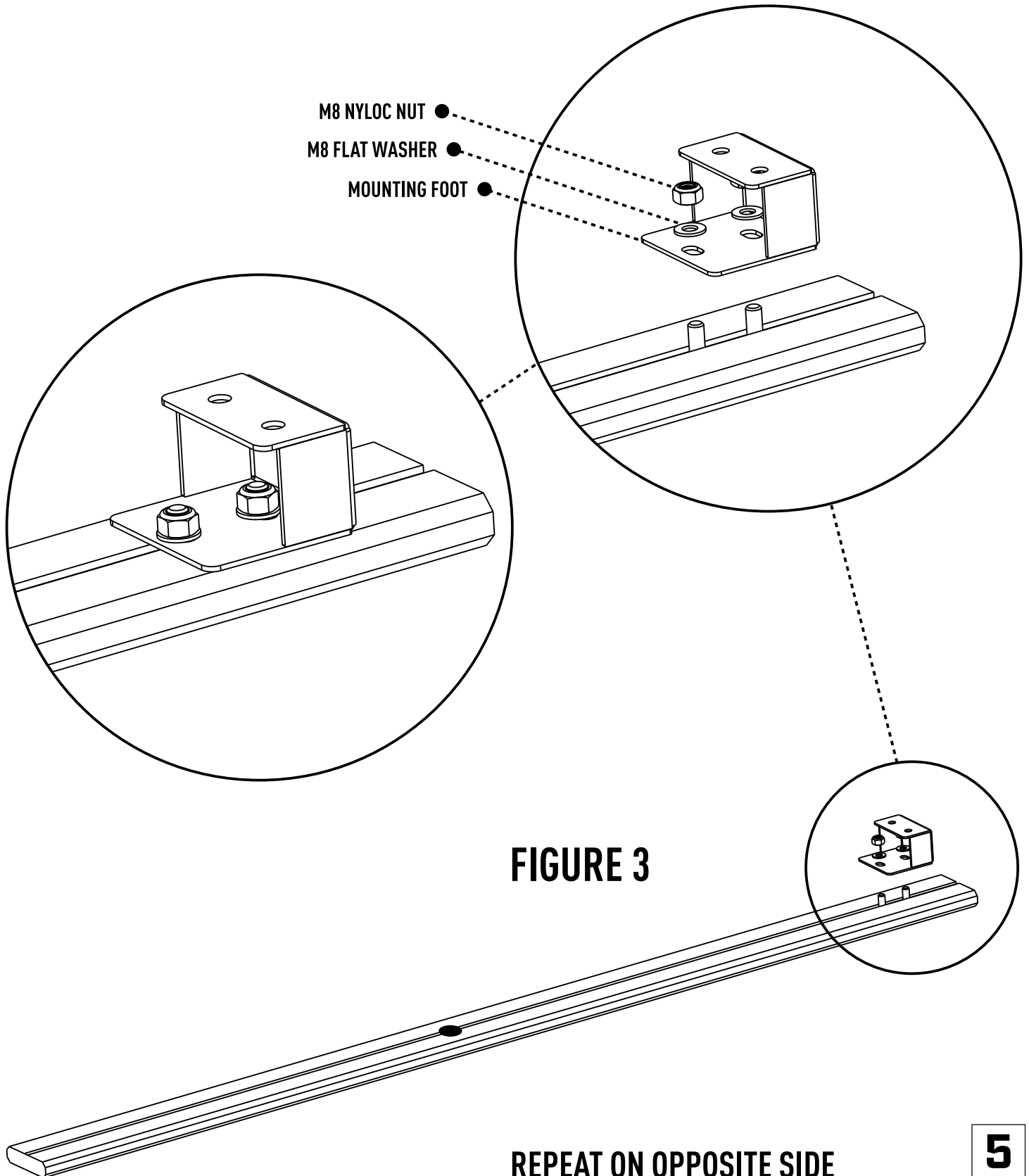

FITMENT OF THE SMARTCAP ACCESSORY

STEP FOUR

1. ONCE THE MOUNTING FEET ARE HAND FASTENED IN PLACE, HAND FASTEN THE MOUNTING HARDWARE. [SEE FIGURE 4]
2. DO NOT FULLY TIGHTEN THE M8 WELDNUTS, ONLY TURN ONCE OR TWICE JUST SO THEY BITE ONTO THE THREAD.
3. FOLLOW THIS PROCESS FOR BOTH LOADBARS.

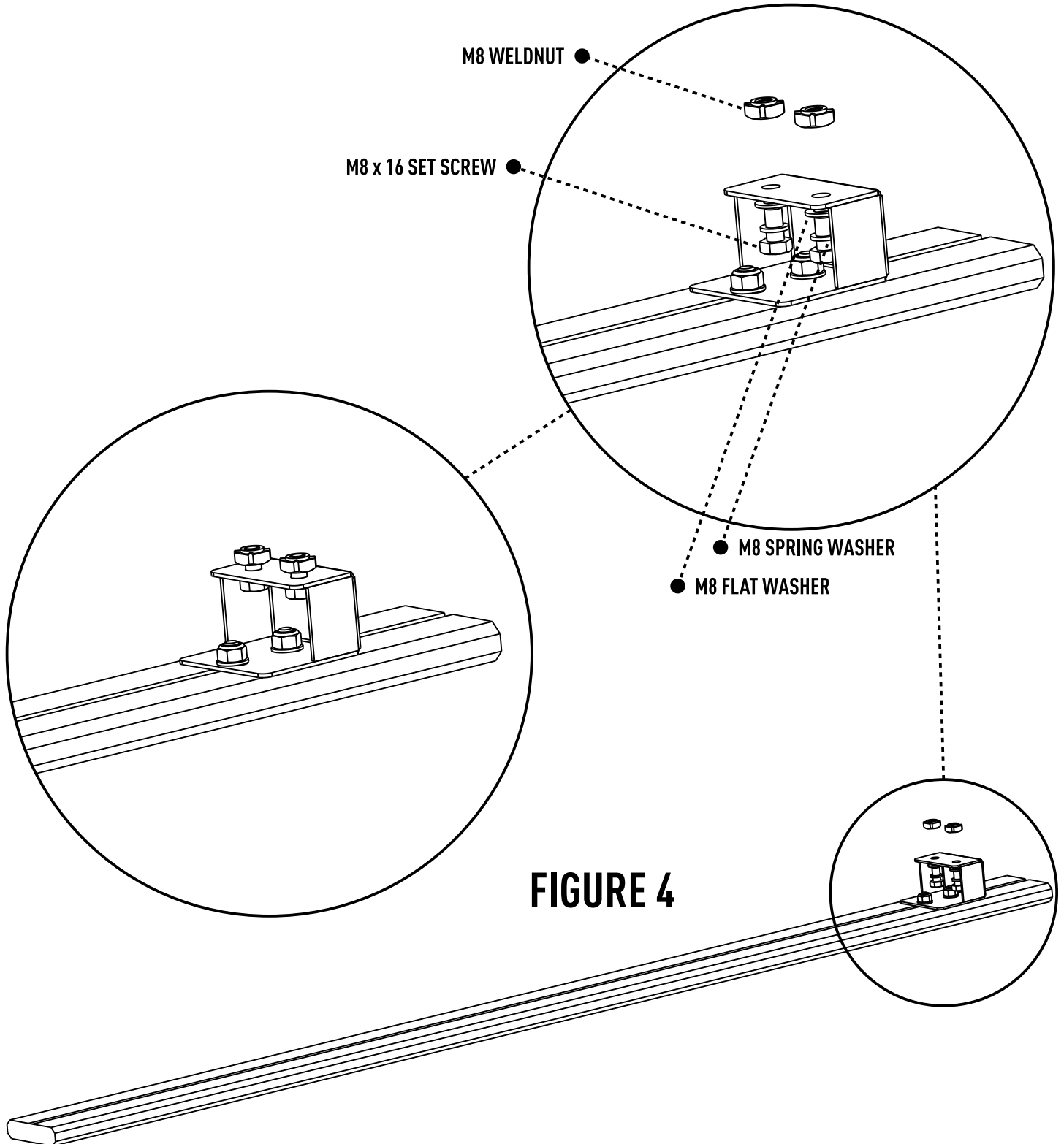

FITMENT OF THE SMARTCAP ACCESSORY

STEP FIVE

1. SLIDE THE M8 WELD NUT INTO THE CAVITY OF THE ROOF RAIL. (SEE FIGURE 5)
2. SLIDE BOTH THE LEFT AND THE RIGHT HAND SIDE INTO THE ROOF RAIL AT THE SAME TIME.
3. FOLLOW THIS PROCESS FOR BOTH LOADBARS. (FRONT AND REAR)

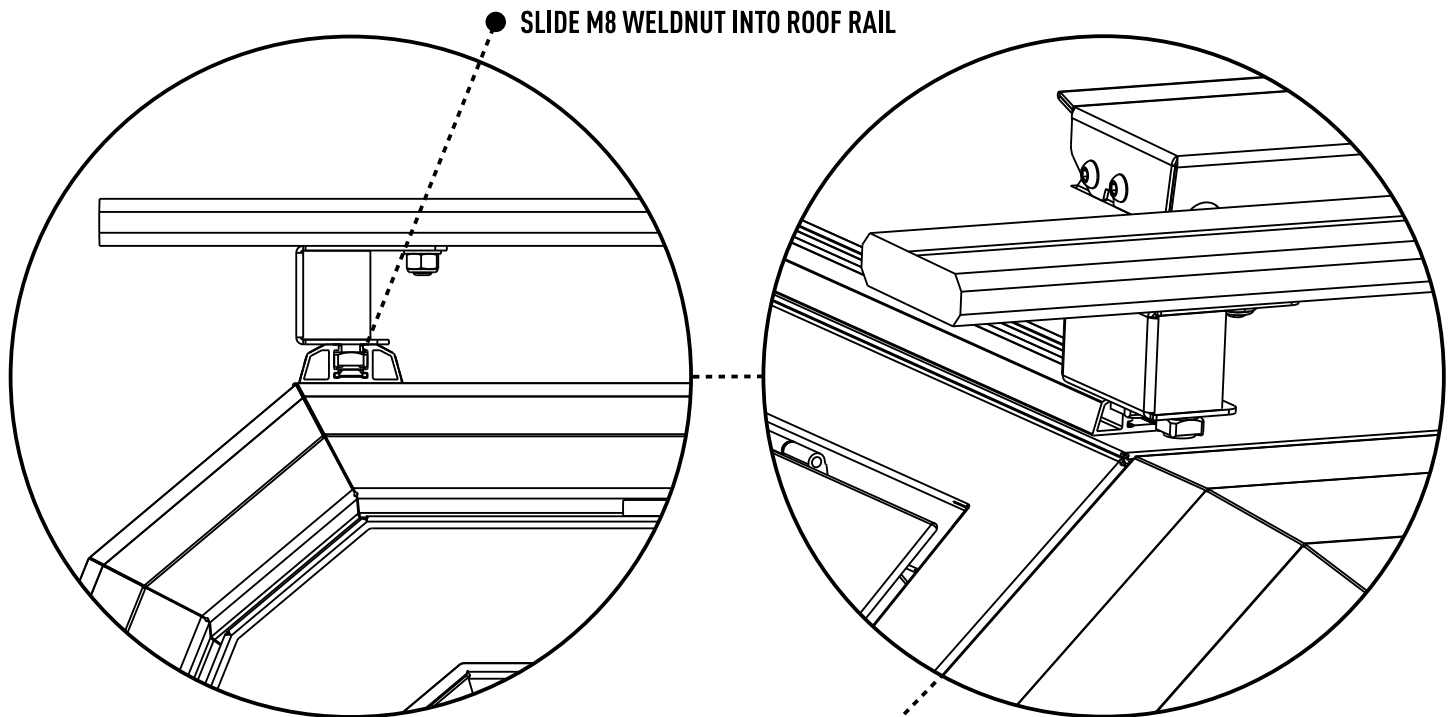
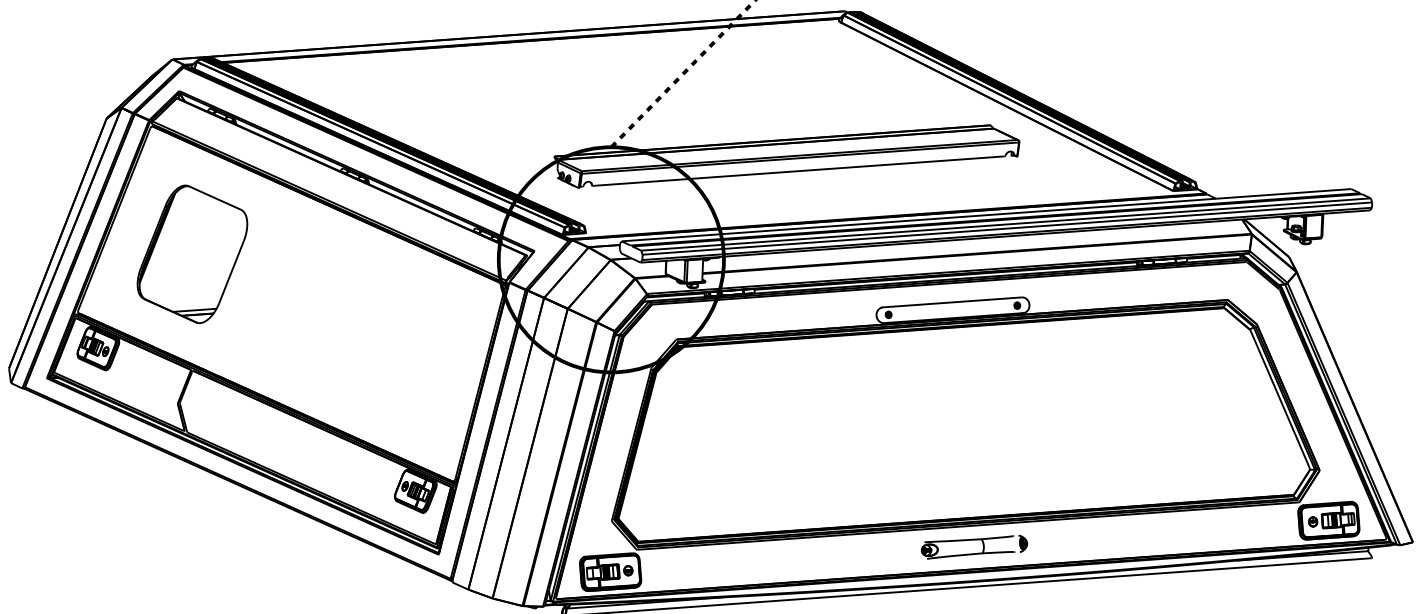

FIGURE 5



FITMENT OF THE SMARTCAP ACCESSORY

STEP SIX

1. THE BEST POSITIONS FOR THE LOADBARS TO BE FASTENED IS ABOUT 50MM (2.17 INCHES) MEASURED FROM THE ROOF RAIL FACE INWARDS. [SEE FIGURE 6]
2. CENTRALISE LOADBARS FROM LEFT TO RIGHT. [SEE FIGURE 7]
3. WHEN LOADBARS ARE IN THEIR CORRECT POSITION AND CENTRALISED PROCEED TO FASTEN ALL THE HARDWARE SUFFICIENTLY.
4. DO NOT FORGET TO RE-FIT THE ROOF RAIL ENDCAPS WHEN THE LOADBARS ARE SECURELY FITTED.

FIGURE 6

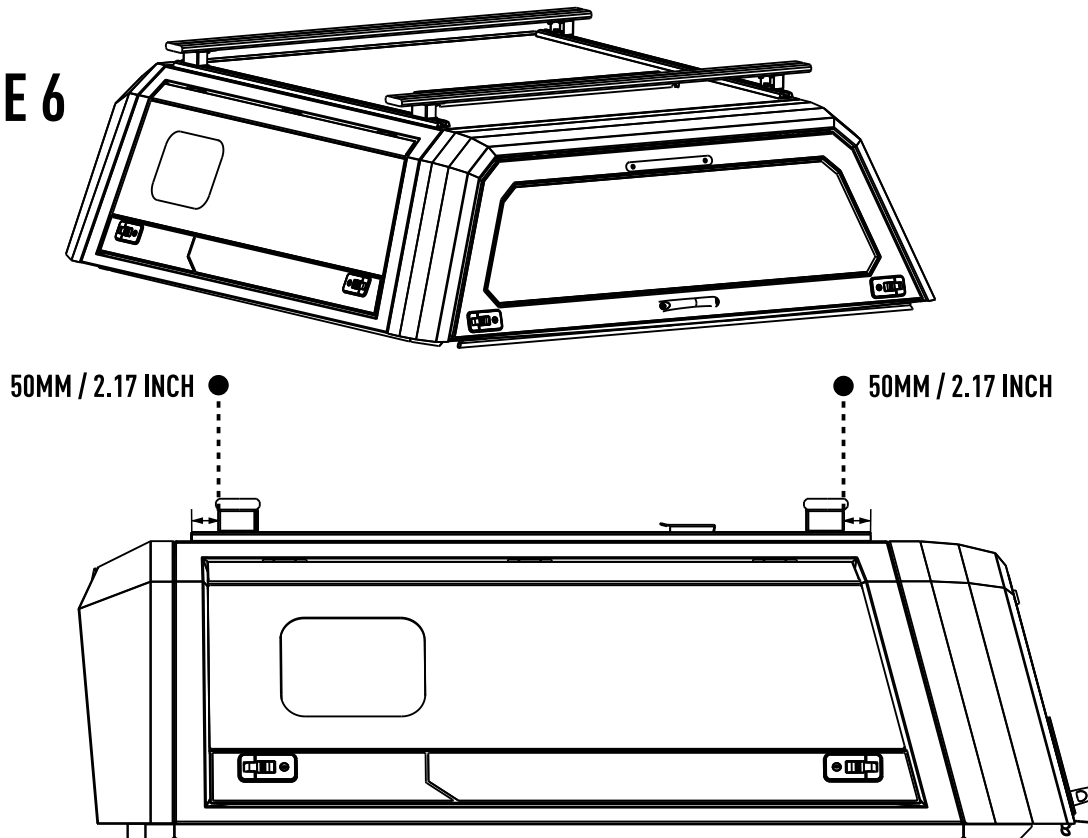

FIGURE 7

