

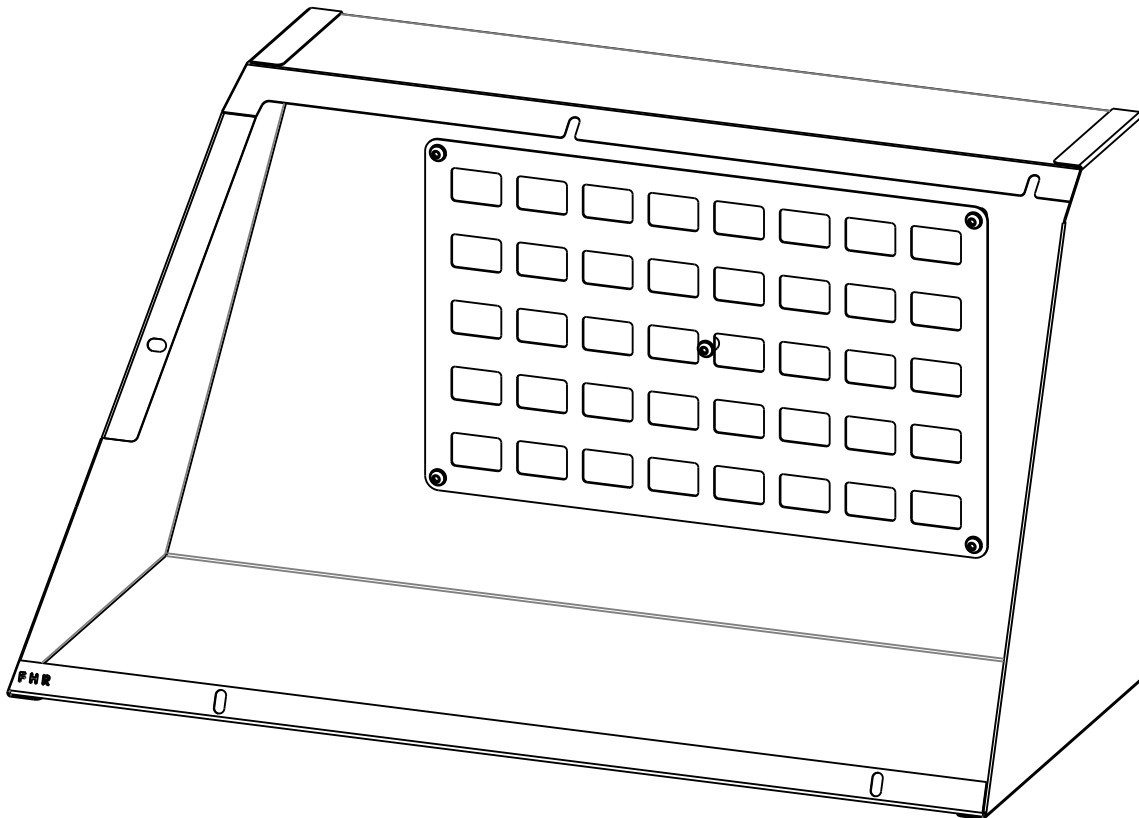

## Half-Bin (Left or Right Mounted) Installation Guide



**FOLLOW INSTRUCTIONS CAREFULLY TO AVOID ANY DAMAGE TO YOUR SMARTCAP PRODUCT OR YOUR VEHICLE**

**IF YOU HAVE QUESTIONS OR CONCERNS, PLEASE DO NOT HESITATE TO CONTACT US AT:**

SUPPORT.NA@RSISMARTCAP.COM - NORTH AMERICA

[SUPPORT.SA@SMARTCAP.COM](mailto:SUPPORT.SA@SMARTCAP.COM) - INTERNATIONAL/SOUTH AFRICA



# COMPONENTS



**5X** M6  
NYLOC NUTS

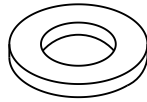

**5X** M6  
FLAT WASHERS

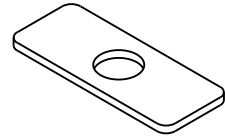

**5X** LOADSPREADER  
PLATES

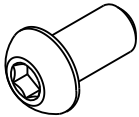

**5X** M6 X 12  
BUTTON HEAD SCREWS

# REQUIRED TOOLS

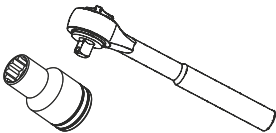

**SOCKET WRENCH**  
10mm SOCKET

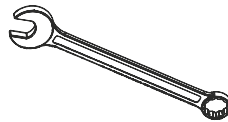

**COMBINATION WRENCH**  
10mm FLAT

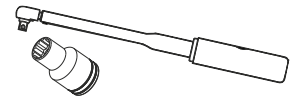

**TORQUE WRENCH**  
10mm FLAT

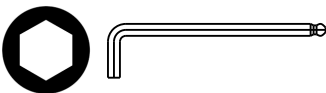

**ALLEN KEY SET**  
4MM

# WARNING



- ONLY USE THE RECOMMENDED TOOLS AS INDICATED IN THE INSTALLATION GUIDE ABOVE.
- ONLY USE THE HARDWARE PROVIDED IN THE FITMENT KIT OUTLINED ABOVE.
- HANDLE ALL RSI COMPONENTS WITH CARE UPON UNPACKING.
- IT IS RECOMMENDED THAT THE MINIMUM OF TWO PEOPLE LIFT THE RSI PRODUCT.
- NEVER USE ACETONE ON PAINTWORK

## SMARTBIN ORIENTATION:

REAR

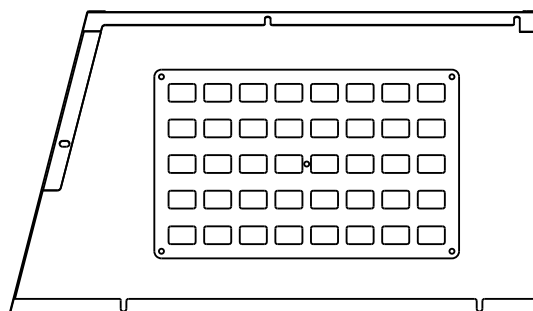

FRONT

# FITMENT OF THE RSI ACCESSORY

## STEP ONE

1. HAND FASTEN THE HARDWARE ALONG THE TOP MOUNTING FACE ON THE SIDE PANEL. [SEE FIGURE 1]
2. LIFT THE RSI SMARTBIN UNIT AND HOOK INTO POSITION, A MINIMUM OF 2 PEOPLE ARE RECOMMENDED TO LIFT AND ALIGN THE RSI SMARTBIN. [SEE FIGURE 2]

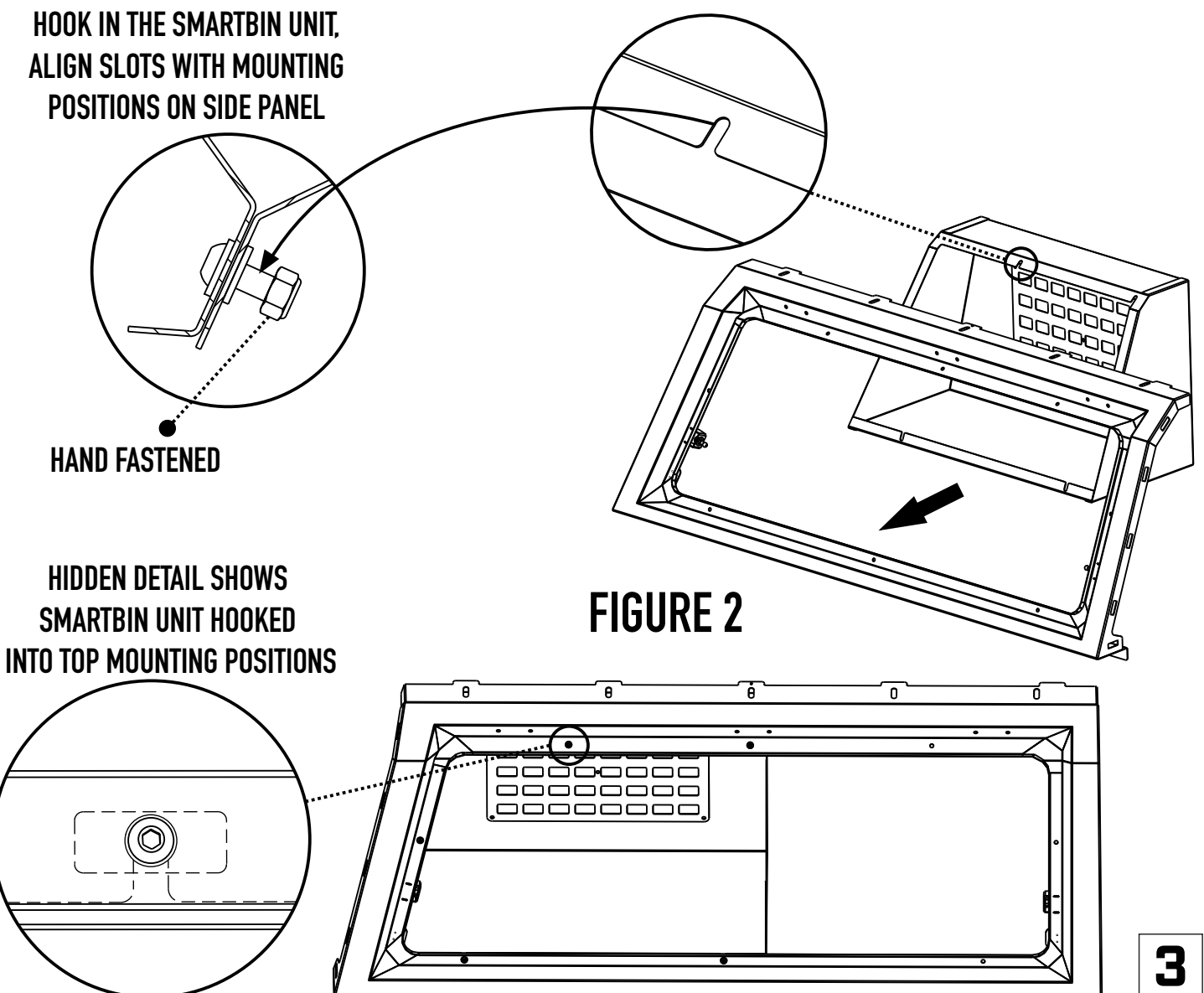
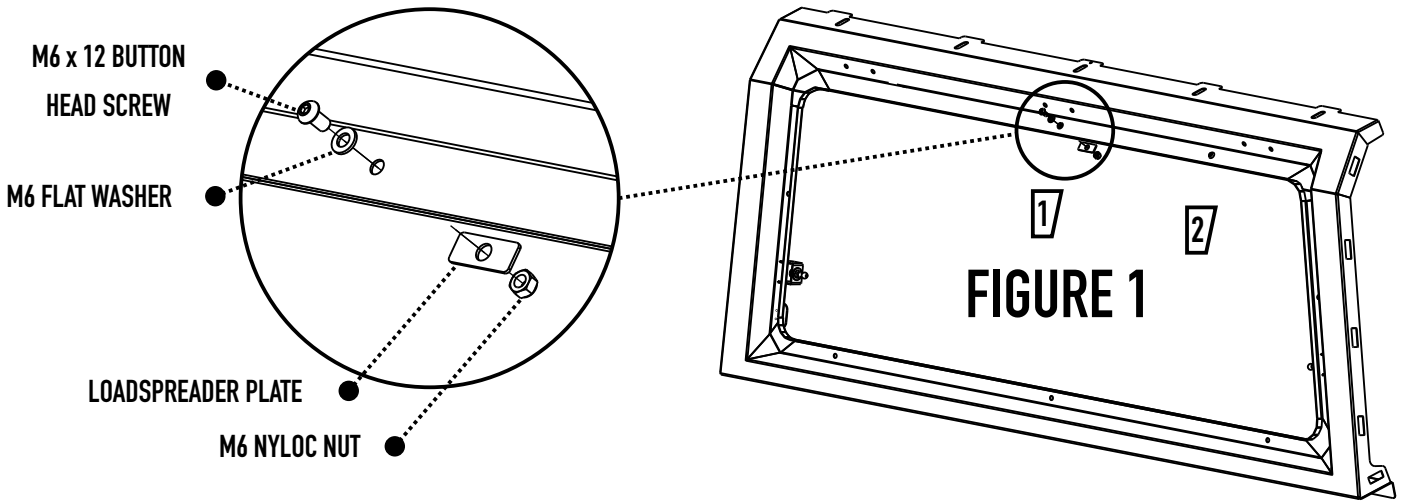

# FITMENT OF THE RSI ACCESSORY

## STEP TWO

1. WHEN THE TOP IS SECURED FOLLOW THE SAME FASTENING METHOD SHOWN IN FIGURE 3 FOR THE REST OF THE MOUNTING POINTS.
2. ALIGN THE LOADSPREADER PLATES WITH SIDE PANEL EDGE.(SEE FIGURE 4)
3. FASTEN ALL FASTENERS TO 9FT-LB, 108 IN-LB OR 12.2 NM

