

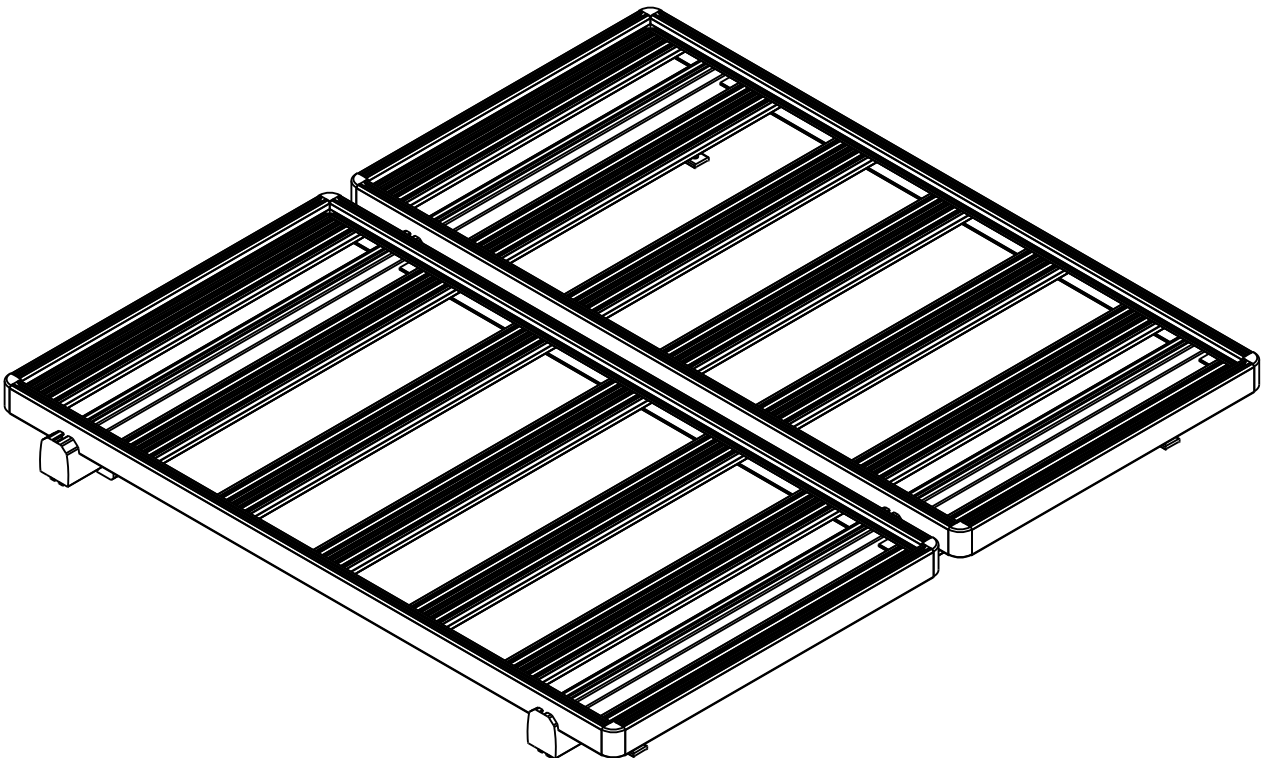

## Drop Rack Installation Guide



**FOLLOW INSTRUCTIONS CAREFULLY TO AVOID ANY DAMAGE TO YOUR SMARTCAP PRODUCT OR YOUR VEHICLE**

**IF YOU HAVE QUESTIONS OR CONCERNS, PLEASE DO NOT HESITATE TO CONTACT US AT:**

SUPPORT.NA@RSISMARTCAP.COM - NORTH AMERICA

[SUPPORT.SA@SMARTCAP.COM](mailto:SUPPORT.SA@SMARTCAP.COM) - INTERNATIONAL/SOUTH AFRICA



# COMPONENTS



**8X** M6  
NYLOC NUTS

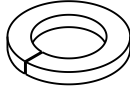

**8X** M8  
FLAT WASHERS

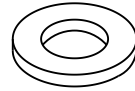

**8X** M8  
FLAT WASHERS



**8X** M8  
WELD NUTS



**2X** LOCATING  
GAUGE

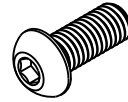

**8X** M8 X 20  
BUTTON HEAD SCREW

# REQUIRED TOOLS

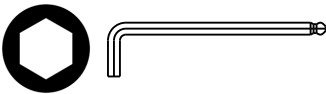

ALLEN KEY SET

# OPERATION GUIDE

## STEPS

1. RELEASE LOCKING LATCHES FRONT AND REAR TO RELEASE DROP RACK
2. PULL OUT RACK TO FURTHEST POSITION
3. ALLOW RACK TO LOWER UNASSISTED
4. DO NOT EXCEED 70LB LOAD CAPACITY
5. RAISE RACK TO ROOF LEVEL
6. FULLY CLOSE THE DROP RACK TO RESET THE DAMPER BEFORE REUSE.
7. ENGAGE LATCHES BEFORE MOVING VEHICLE

## WARNING

- USE ONLY THE TOOLS RECOMMENDED IN THIS GUIDE
- USE ONLY THE HARDWARE THAT HAS BEEN PROVIDED
- HANDLE ALL COMPONENTS WITH CARE
- IT IS RECOMMENDED THAT FOUR PEOPLE LIFT/LOWER THE SMARTCAP
- NEVER USE ACETONE ON THE PAINTWORK
- AVOID PINCHING/SQUASHING HANDS

2



# INSTALLATION OF THE ACCESSORY

## STEP ONE

1. REMOVE THE REAR ENDCAPS THAT ARE FASTENED TO THE ENDS OF THE RSI SMARTCAP ROOF RAILS. (SEE FIGURE 1)
2. DO NOT MISPLACE THE ENDCAPS OR FASTENERS AS THEY NEED TO BE RE - FITTED.
3. SLIDE 4 x M8 WELDNUTS INTO EACH OF THE ROOF RAILS.(SEE FIGURE 2)
4. WHEN THE M8 WELD NUTS ARE IN PLACE, RE - FIT THE ROOF RAIL ENDCAPS.

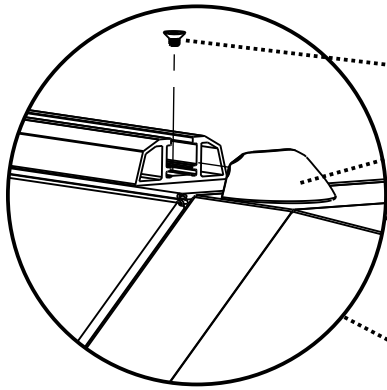

- CSK SCREW SUPPLIED WITH ROOF RAIL
- ROOF RAIL ENDCAP

FIGURE 1

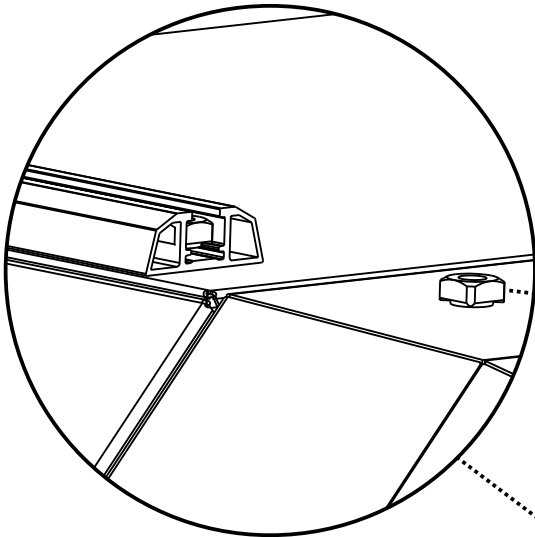
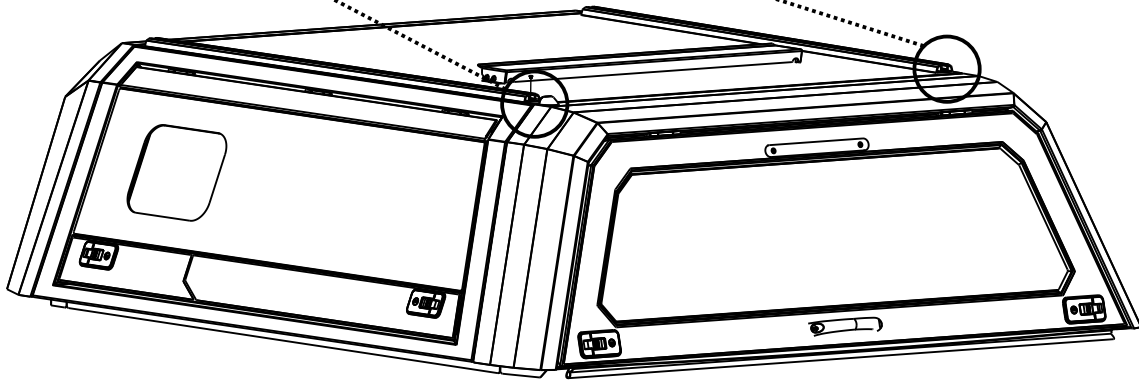

- SLIDE M8 WELDNUTS INTO THE ROOF RAIL

FIGURE 2

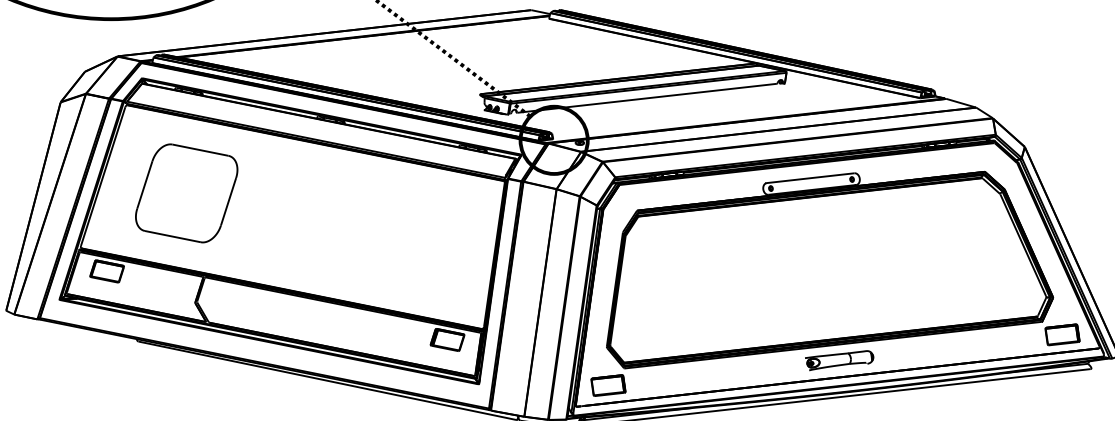

# INSTALLATION OF THE ACCESSORY

## STEP TWO

1. PLACE THE 2 LOCATING GAUGES INTO THE ROOF RAILS AND SLIDE UP AGAINST THE FRONT END CAPS. [SEE FIGURE 3]
2. IDENTIFY THE END OF THE SMART RACK WHICH IS LABELLED AS THE FRONT. [SEE FIGURE 4]
3. CAREFULLY PLACE THE SMART RACK ONTO THE ROOF RAILS, WITH THE FRONT MOUNTING FEET LOCATED UP AGAINST THE LOCATING GAUGES. [SEE FIGURE 5]
4. PLEASE NOTE THAT THE SMART RACK FEET HAVE A PROFILE MATCHING THAT OF THE ROOF RAILS TO FACILITATE EASE OF FITMENT. [SEE FIGURE 5]
5. ALIGN THE WELDNUTS, WHICH WERE FITTED IN STEP 1, WITH THE SMART RACK MOUNTING HOLES. [SEE FIGURE 5]
6. AFFIX THE SMART RACK USING THE SUPPLIED FASTENERS. [SEE FIGURE 6]
7. REMOVE THE LOCATING GAUGES FROM THE ROOF RAILS.

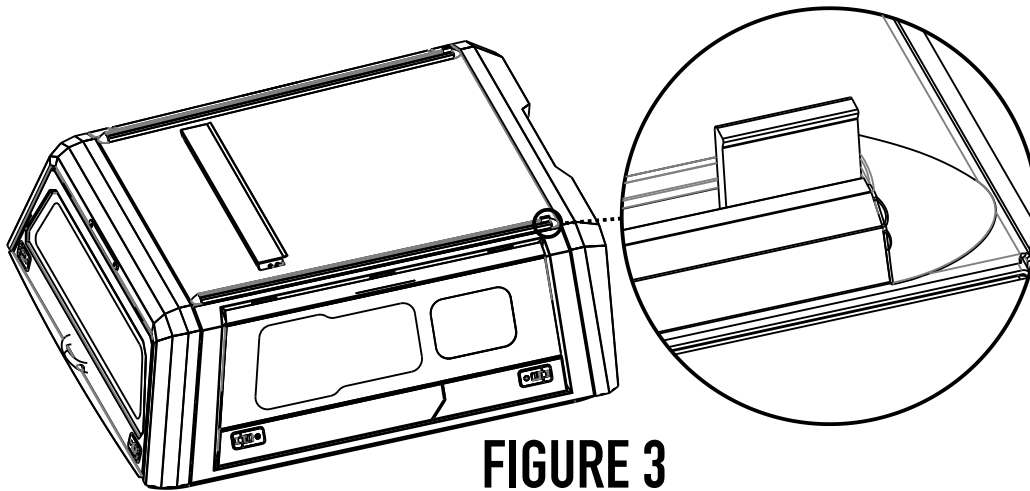

FIGURE 3

STICKER INDICATING FRONT

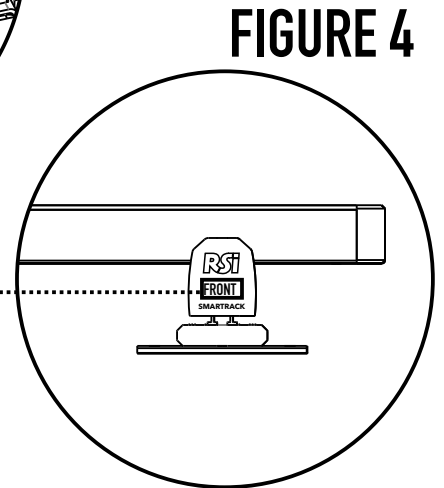

FIGURE 4

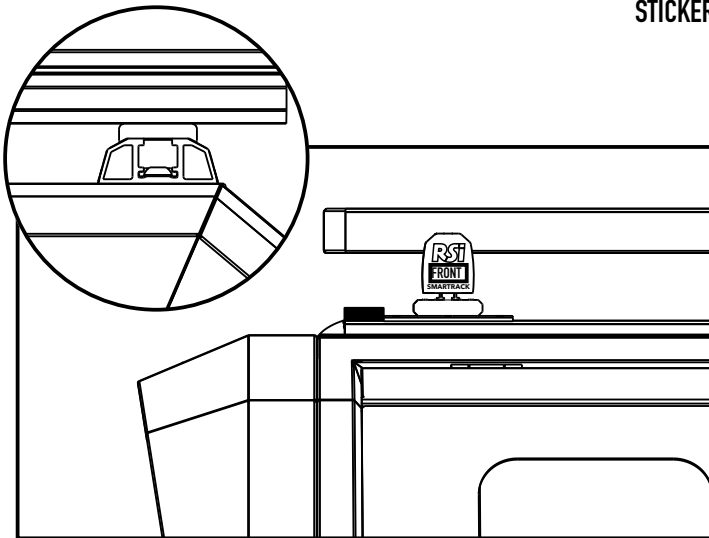

FIGURE 5

M8 x 20 BUTTON HEAD SCREW  
M8 SPRING WASHER  
M8 FLAT WASHER

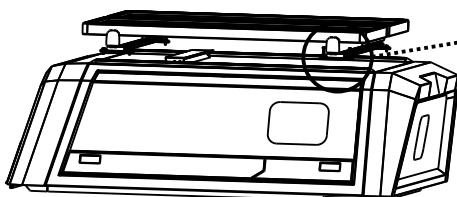

FIGURE 6