

SMARTCAP[®]

INSTRUCTION GUIDE SECURITY SCREEN

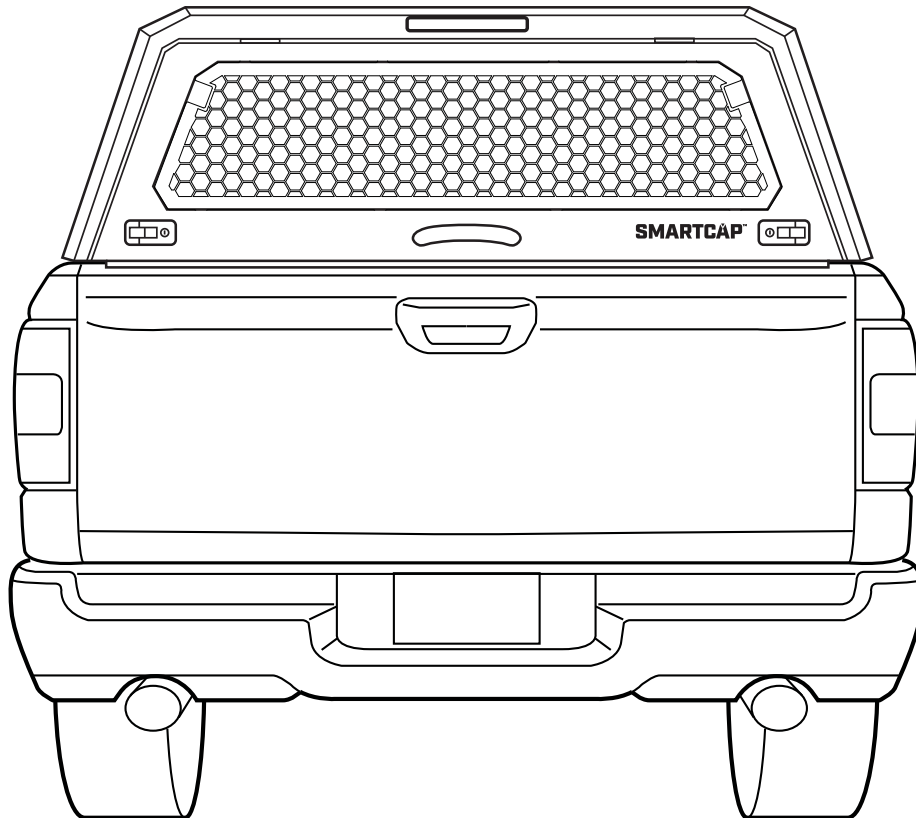

- ▼ **PREPARE A CLEAN WORK AREA.**
- ▼ **ENSURE THE REQUIRED TOOLS ARE PRESENT AND ALL HARDWARE CONTENTS ARE ACCOUNTED FOR.**
- ▼ **NEVER USE ACETONE OR THINNERS ON PAINTED PARTS.**
- ▼ **READ THROUGH THE ENTIRE INSTRUCTION GUIDE BEFORE STARTING THIS PROCEDURE AND FOLLOW THE STEPS CAREFULLY TO AVOID ANY DAMAGE TO THE COMPONENTS OR THE VEHICLE.**

SMARTCAP.COM

SUPPORT.NA@SMARTCAP.COM - NORTH AMERICA

SUPPORT.SA@SMARTCAP.COM - REST OF WORLD



I-SHEET-NA-SS



IMPORTANT

- ▼ USE ONLY THE TOOLS RECOMMENDED ABOVE.
- ▼ USE ONLY THE HARDWARE PROVIDED IN THIS KIT.
- ▼ AVOID PINCHING OR CRUSHING HANDS AND FINGERS.
- ▼ INSPECT ALL KIT COMPONENTS FOR DAMAGE BEFORE ASSEMBLY.

TOOLS REQUIRED

4mm ALLEN KEY



INSTALLATION HARDWARE

MOUNTING PLATE
ADAPTER



MOUNTING PLATE
ADAPTER



M6x16mm
BUTTON HEAD BOLT

