

**SMARTCAP®**

## **INSTRUCTION GUIDE EVO, EVOa & EVOc SERIES**



- ▼ **PREPARE A CLEAN WORK AREA.**
- ▼ **WE RECOMMEND A MINIMUM OF 2 PEOPLE FOR ASSEMBLY.**
- ▼ **ENSURE THE REQUIRED TOOLS ARE PRESENT AND ALL HARDWARE CONTENTS ARE ACCOUNTED FOR.**
- ▼ **NEVER USE ACETONE OR THINNERS ON PAINTED PARTS.**
- ▼ **READ THROUGH THE ENTIRE INSTRUCTION GUIDE BEFORE STARTING THIS PROCEDURE AND FOLLOW THE STEPS CAREFULLY TO AVOID ANY DAMAGE TO THE COMPONENTS OR THE VEHICLE.**

**SMARTCAP.COM**

SUPPORT.NA@SMARTCAP.COM - NORTH AMERICA

SUPPORT.SA@SMARTCAP.COM - REST OF WORLD



I-SHEET-NA-U3

## TOOLS REQUIRED

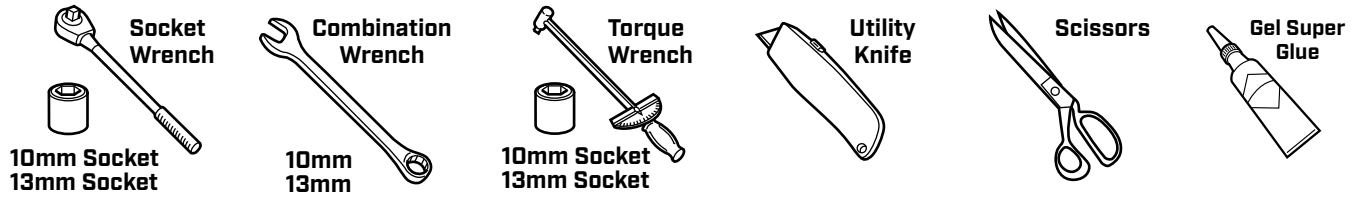

## IMPORTANT

- ▶ USE ONLY THE TOOLS RECOMMENDED ABOVE.
- ▶ USE ONLY THE HARDWARE PROVIDED IN THIS KIT.
- ▶ ASSISTANCE WILL BE NEEDED FOR THIS INSTALLATION. FOUR PEOPLE ARE RECOMMENDED TO LIFT THE SMARTCAP ONTO THE VEHICLE.
- ▶ AVOID PINCHING OR CRUSHING HANDS AND FINGERS.
- ▶ INSPECT ALL KIT COMPONENTS FOR DAMAGE BEFORE ASSEMBLY.
- ▶ NEVER USE ACETONE OR THINNERS ON PAINTED PARTS.

## COMPONENTS

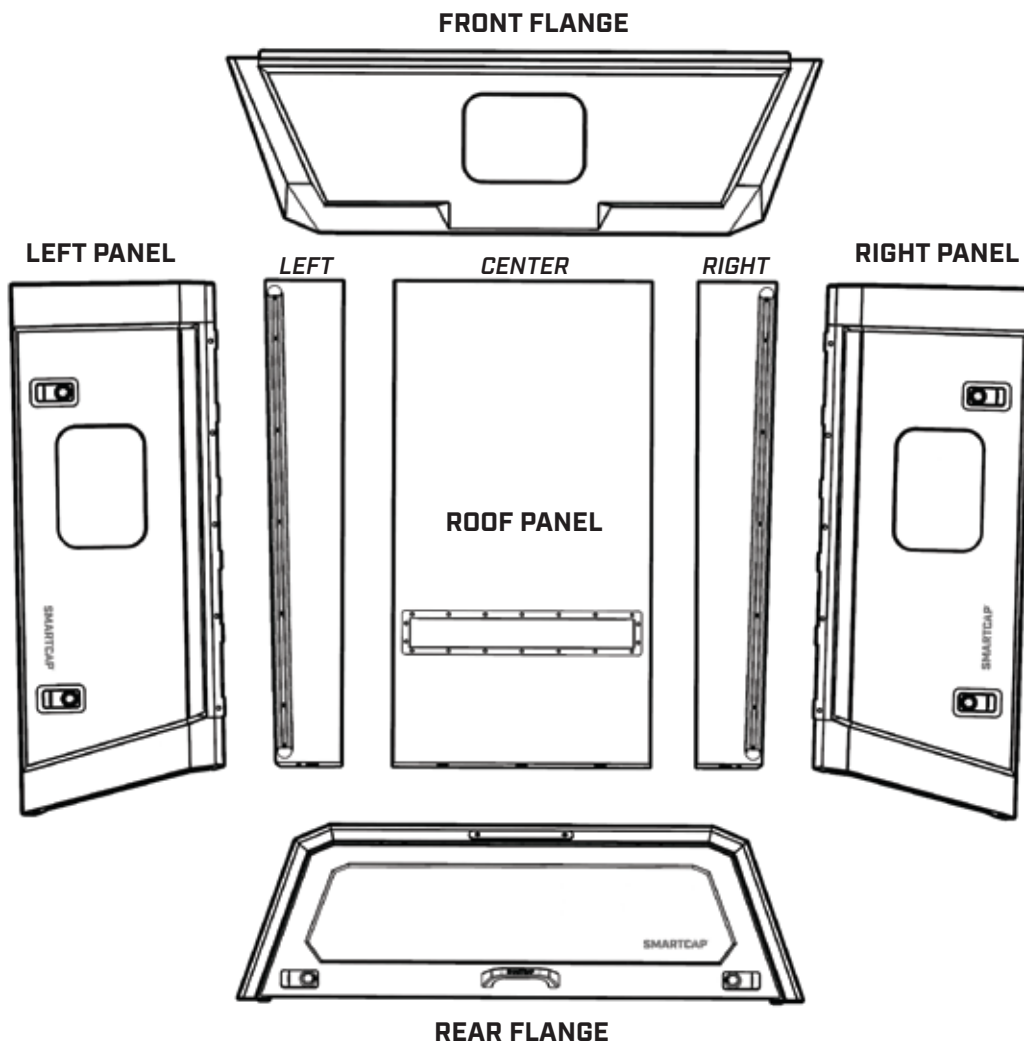

I-SHEET-NA-U3

# ASSEMBLY HARDWARE

## FITMENT KIT

**M6 BOLT**

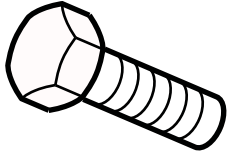

**42X**

**FASTENER  
BLOCK CLAMP**

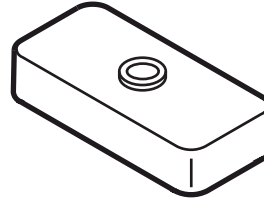

**42X**

**M6 LOCK  
WASHER**

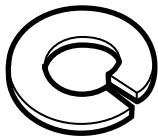

**42X**

**FASTENER  
BLOCK**

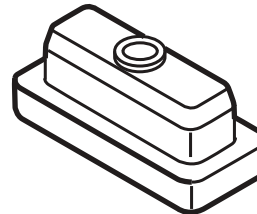

**42X**

**O - RUBBER**



**1X**

**SPARE PARTS**

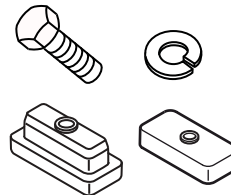

**2X**

## PRE-FASTENED TO ROOF PANEL

**M6  
FENDER  
WASHER**

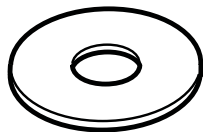

**10X**

**SHORT BED**

**12X**

**STANDARD BED**

**M6  
LOCK  
NUT**

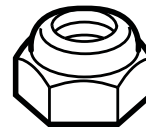

**10X**

**SHORT BED**

**12X**

**STANDARD BED**

# STEP 1



## IMPORTANT

▼ BE SURE TO REMOVE ALL SEVEN PANELS FROM THEIR PACKAGING AND INSPECT THE PAINTED SURFACES PRIOR TO ASSEMBLY, AS SMARTCAP WILL NOT ACCEPT WARRANTY CLAIMS AFTER ASSEMBLY IS COMPLETED. IF MANUFACTURING IMPERFECTIONS OR SHIPPING DAMAGES ARE FOUND, DO NOT CONTINUE WITH THE ASSEMBLY PROCESS AND CONTACT [SUPPORT.NA@SMARTCAP.COM](mailto:SUPPORT.NA@SMARTCAP.COM)

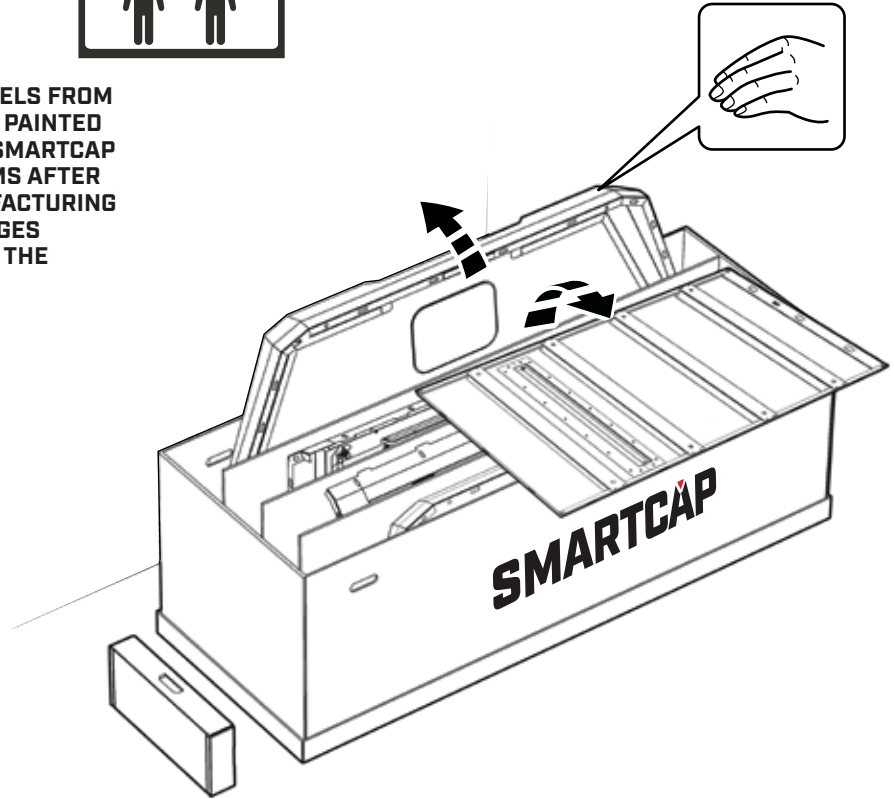

# STEP 2

REMOVE THE FOUR CORNER STIFFENERS AND ONE OF THE CARDBOARD DIVIDERS TO BE USED AS A PROTECTIVE SURFACE DURING ASSEMBLY.

UNFOLD THE CARDBOARD DIVIDER AND PLACE IT WHERE YOU PLAN TO ASSEMBLE YOUR CAP.

PLACE THE FOUR CORNER STIFFENERS AS SHOWN BELOW.

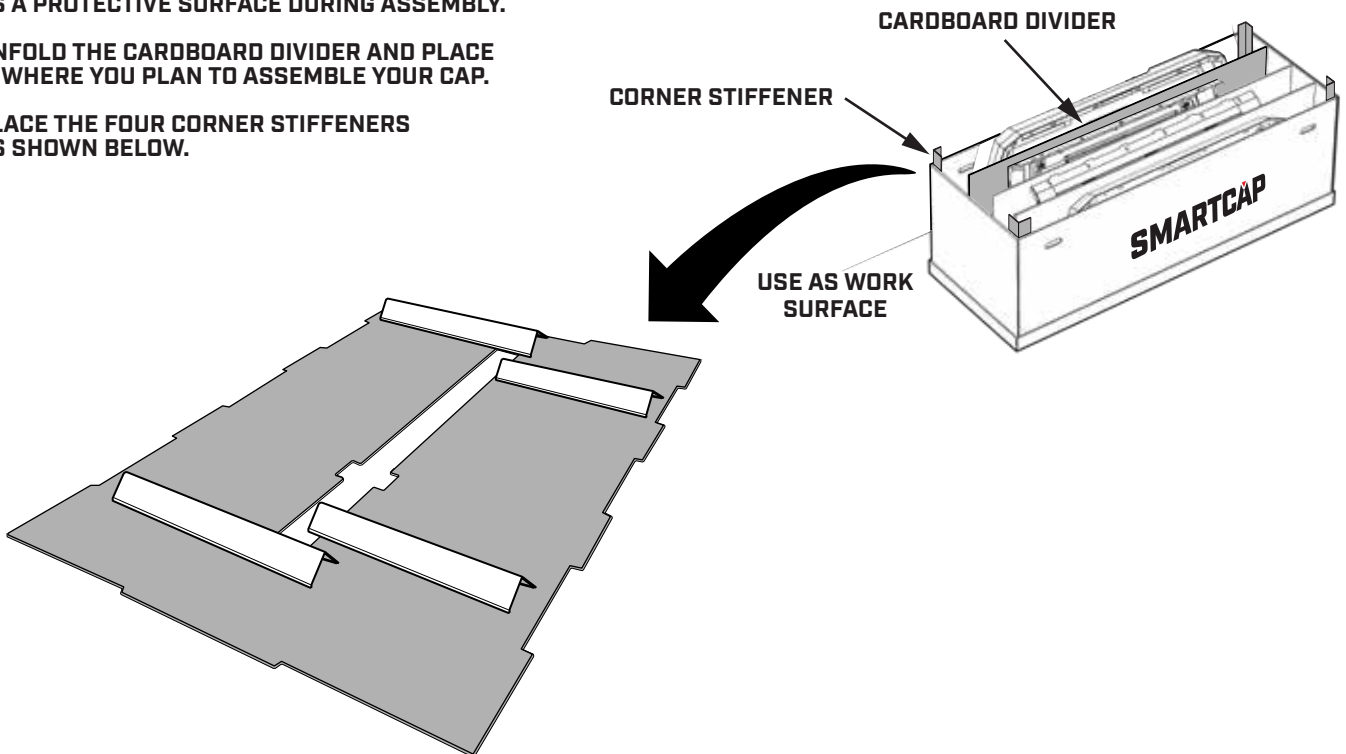

I-SHEET-NA-U3

# STEP 3

PLACE THE ROOF PANELS ON TOP OF THE CORNER STIFFENERS, WITH THE BOTTOM OF THE ROOF PANELS FACING UP.

ALIGN THE PANELS SO THAT THE PROFILE OF THE FRONT AND REAR EDGES MATCH.

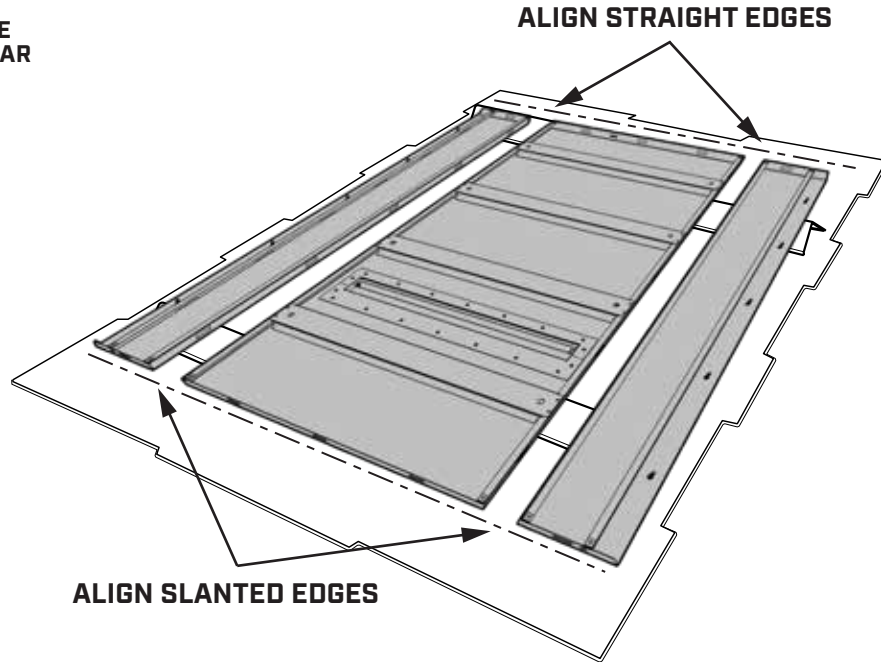

# STEP 4

ASSEMBLE THE FASTENER BLOCKS TO THE ROOF PANELS USING A TORQUE WRENCH AND 10MM SOCKET TO 3.7 FT. LBS [5 NEWTON METERS].

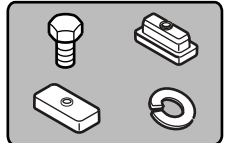

**MAKE SURE ROOF PANELS ARE LEVEL**



- 10X SHORT BED
- 12X STANDARD BED



M6 BOLT

BLOCK CLAMP

M6 LOCK WASHER

FASTENER BLOCK

[3.7 ft. lbs]/[5 Nm]

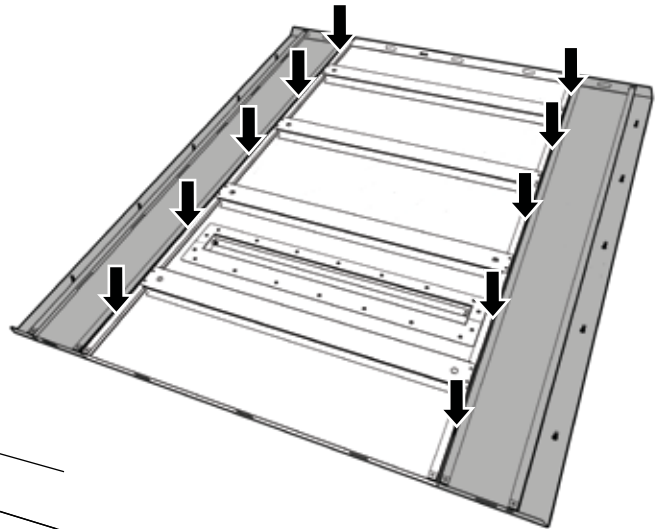

# STEP 5

USE A 10MM COMBINATION WRENCH TO REMOVE THE LOCK NUTS AND FENDER WASHERS FROM THE ROOF BOLTS AND SAVE FOR REUSE.



**AIR VENT INDICATES REAR**

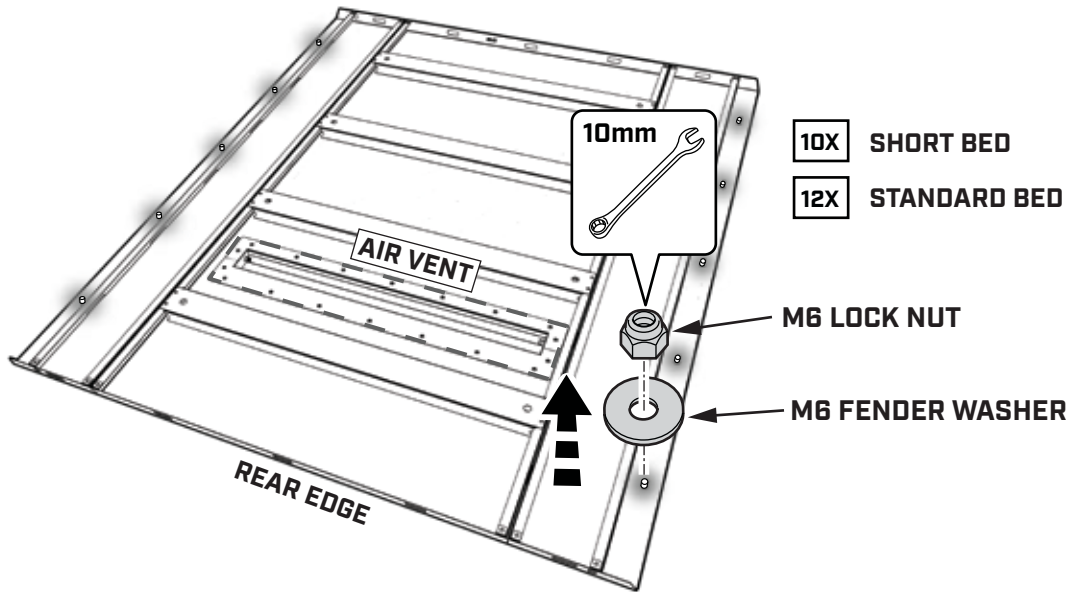

# STEP 6

RETRIEVE THE FASTENER BLOCKS FROM THE FITMENT KIT AND PLACE 15 ON EACH SIDE OF THE ROOF PANEL.

TAKE APART THE FASTENER BLOCKS SO THEY ARE READY TO USE DURING ASSEMBLY.

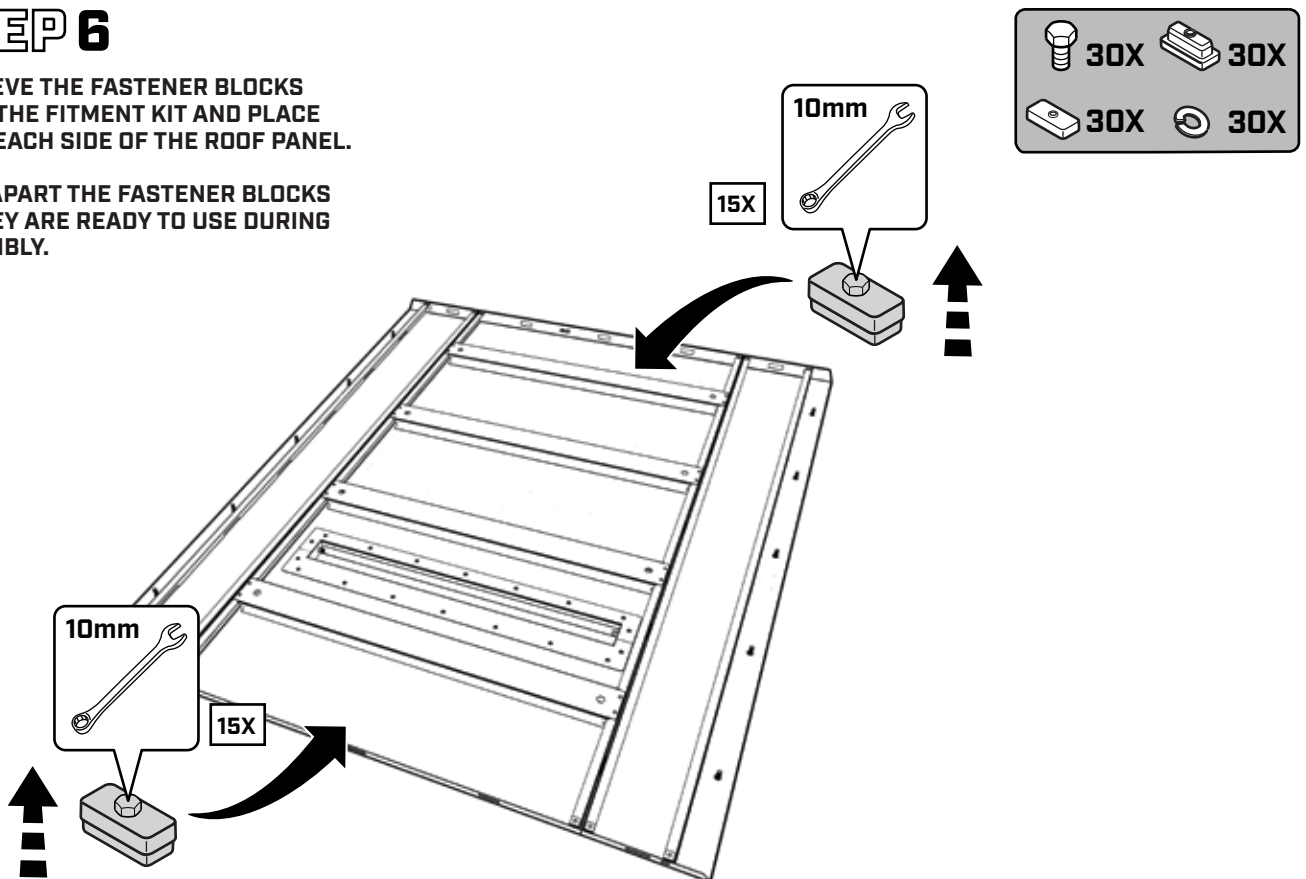

# STEP 7

LOCATE THE RIGHT PANEL IN THE SMARTCAP PACKAGE AND BRING IT TO YOUR WORK AREA.



SLANTED EDGE INDICATES REAR

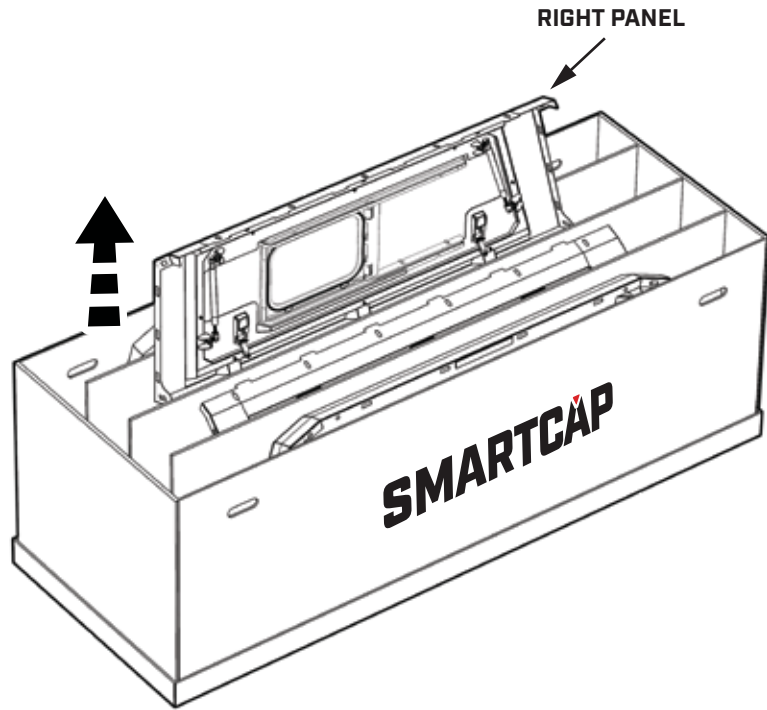

# STEP 8

INSERT PANEL TABS INTO THE NARROW SLOTS JUST ABOVE FOAM PADDING ON ROOF PANEL.

TAP FIRMLY WITH PALM OF HAND UNTIL THERE IS A 2-3MM GAP.

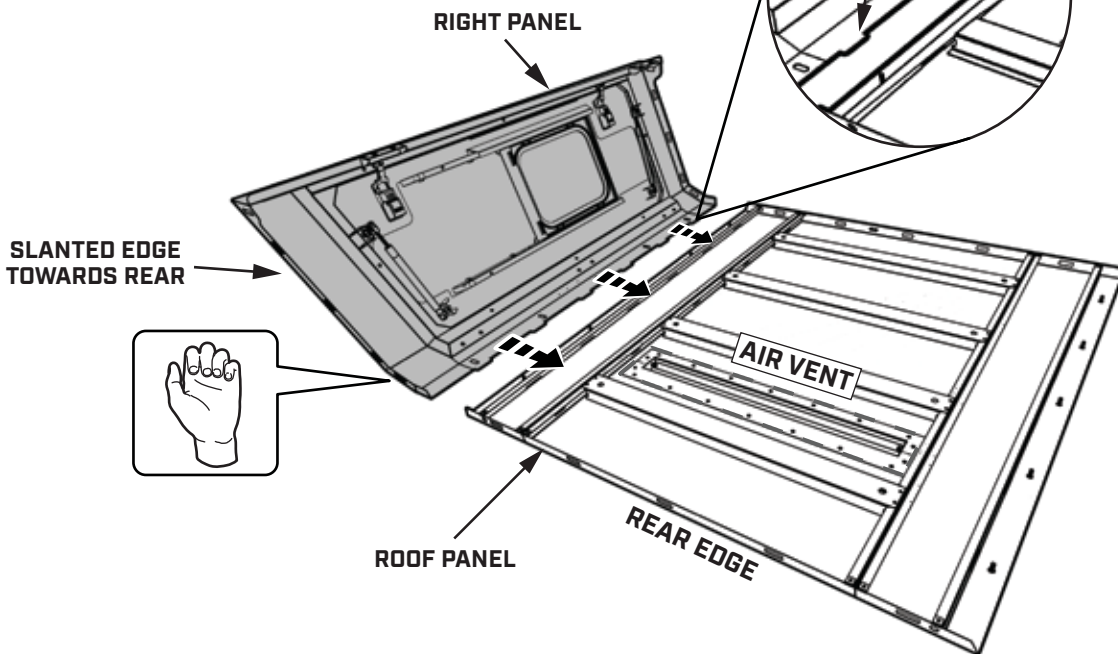
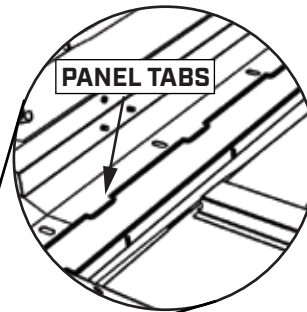

I-SHEET-NA-U3



# STEP 9

HAND TIGHTEN M6 LOCK NUT WITH M6 FENDER WASHER TO ALL BOLTS.

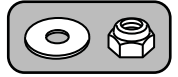

**SUPPORT RIGHT PANEL UNTIL ASSEMBLED TO FRONT FLANGE**

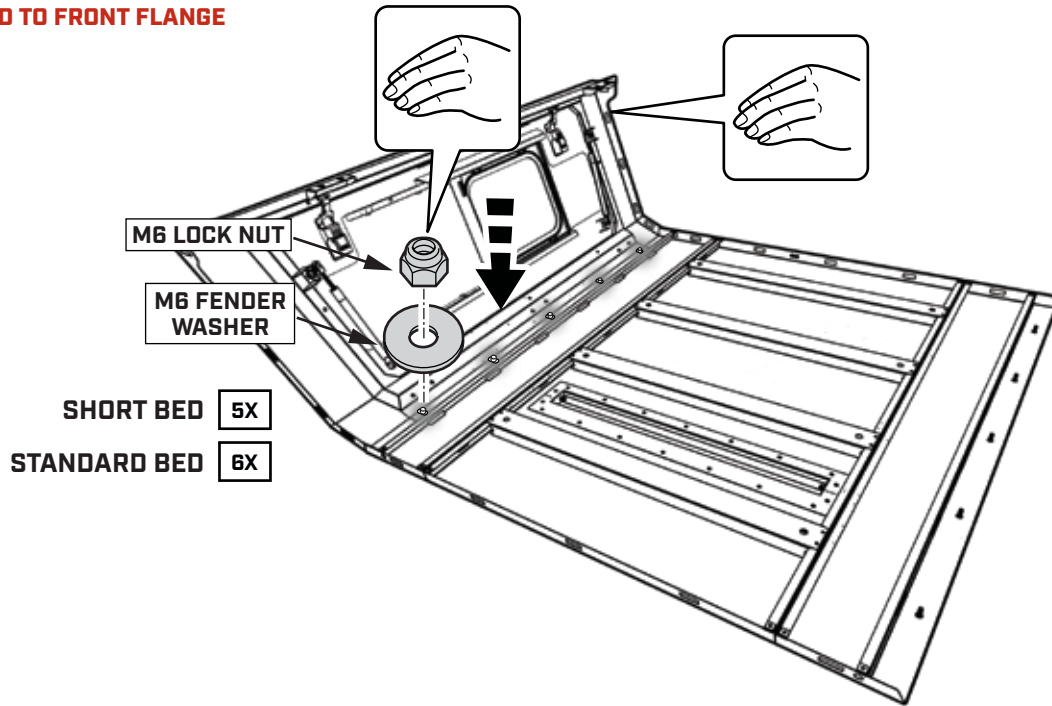

# STEP 10

LOCATE THE FRONT FLANGE IN THE SMARTCAP PACKAGE AND BRING IT TO YOUR WORK AREA.

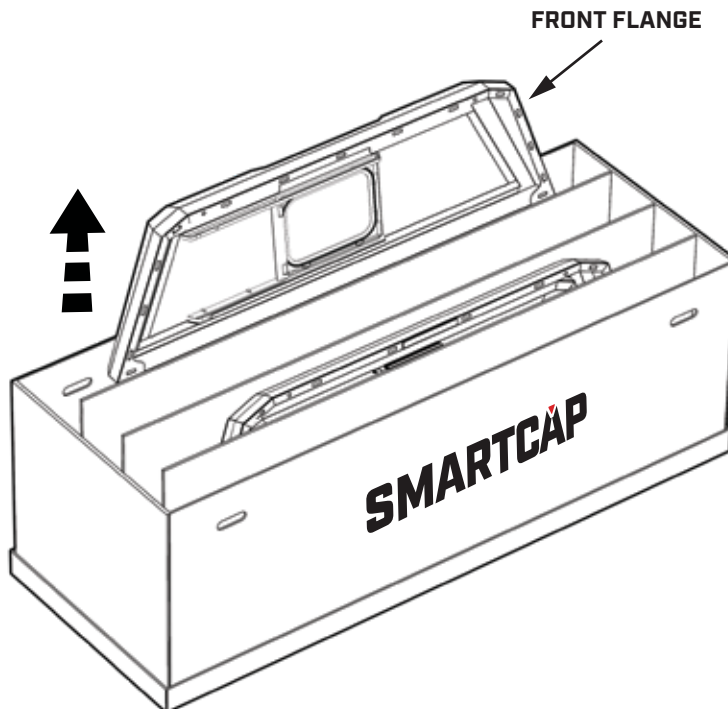



# STEP 11

PLACE FRONT FLANGE AS SHOWN BELOW.

HAND TIGHTEN TWO FASTENER BLOCKS AT THE INDICATED LOCATIONS TO SUPPORT THE RIGHT PANEL AND FRONT FLANGE.

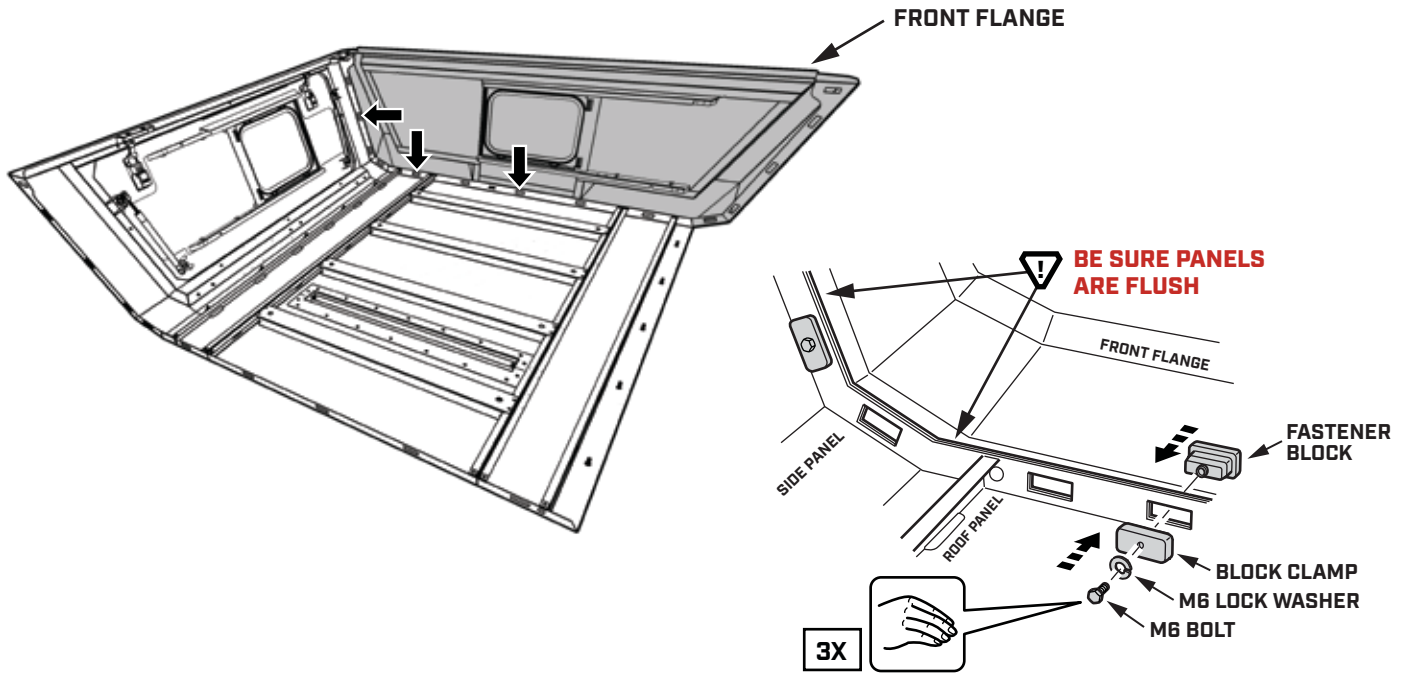

# STEP 12

LOCATE THE LEFT PANEL IN THE SMARTCAP PACKAGE AND BRING IT TO YOUR WORK AREA.



 **SLANTED EDGE INDICATES REAR**

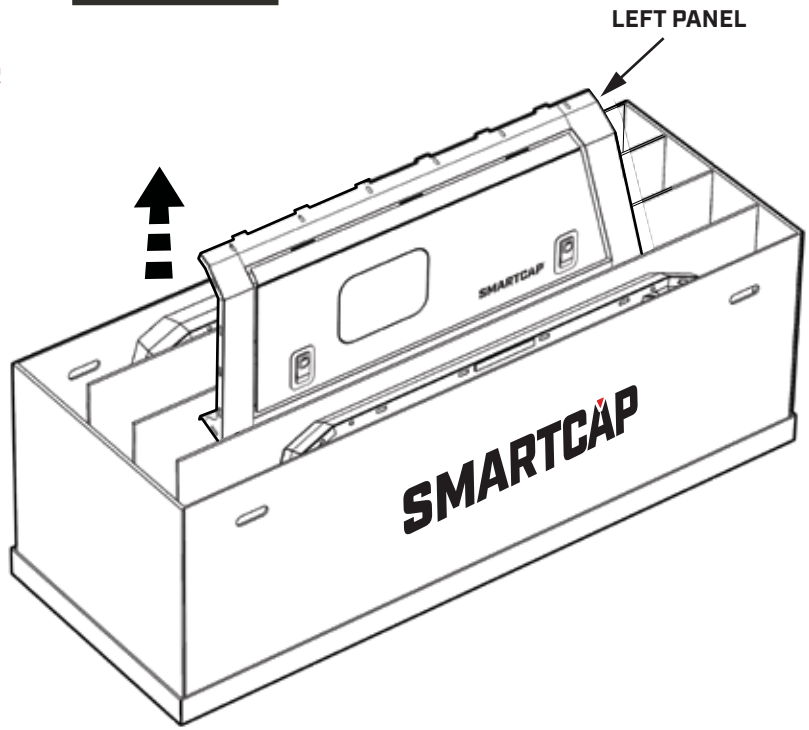

# STEP 13

INSERT PANEL TABS INTO THE NARROW SLOTS JUST ABOVE FOAM PADDING ON ROOF PANEL.

TAP FIRMLY WITH PALM OF HAND UNTIL THERE IS A 2-3MM GAP.

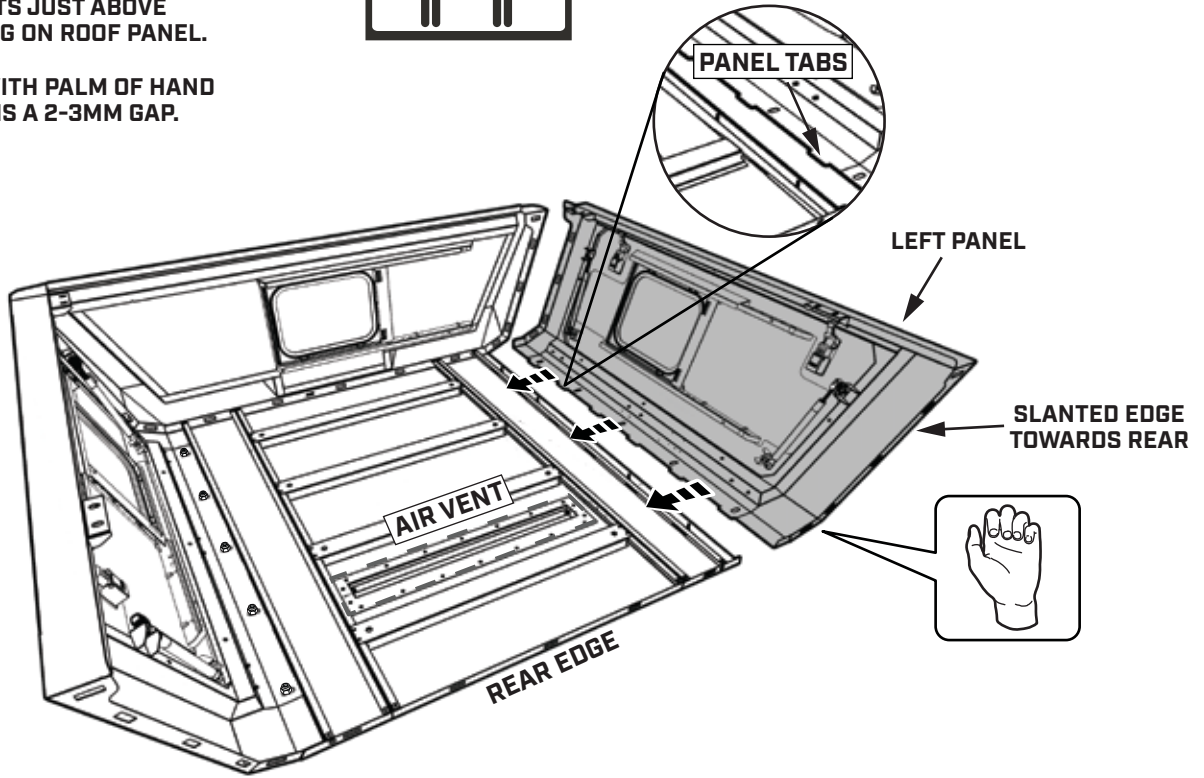

# STEP 14

HAND TIGHTEN M6 LOCK NUT WITH M6 FENDER WASHER TO ALL BOLTS.

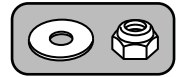

**! SUPPORT LEFT PANEL UNTIL ASSEMBLED TO FRONT FLANGE**

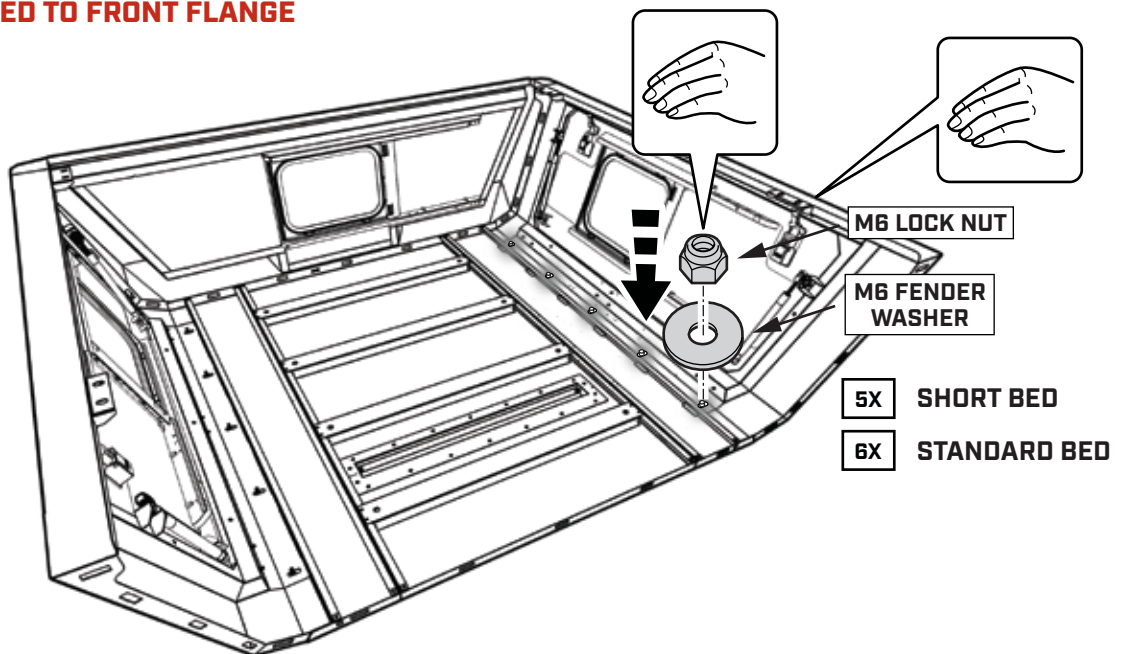

I-SHEET-NA-U3

# STEP 15

INSTALL HARDWARE ALONG FRONT FLANGE WITH BOLT ON INSIDE.

START AT CENTER OF THE FRONT FLANGE AND WORK YOUR WAY OUTWARDS.

ADJUST LEFT AND RIGHT PANELS TO ALIGN THE FASTENER BLOCK HOLES.

HAND TIGHTEN ONLY.

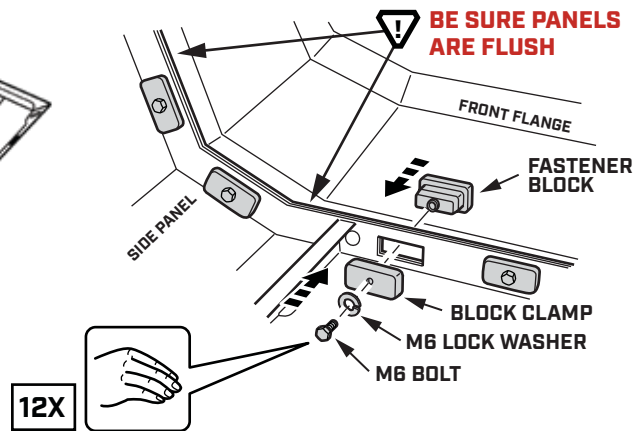
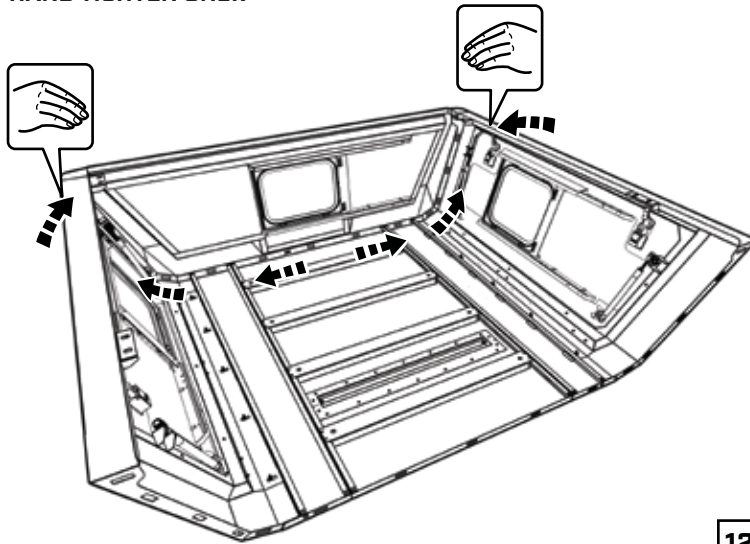
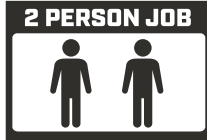

# STEP 16

LOCATE THE REAR FLANGE IN THE SMARTCAP PACKAGE AND BRING IT TO YOUR WORK AREA.

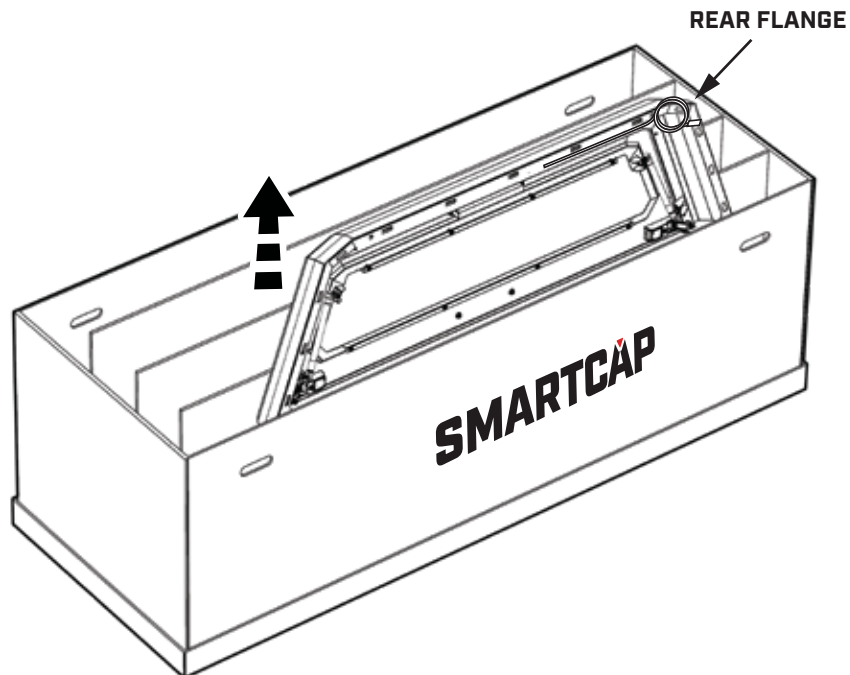

# STEP 17

PLACE REAR FLANGE AS SHOWN BELOW.

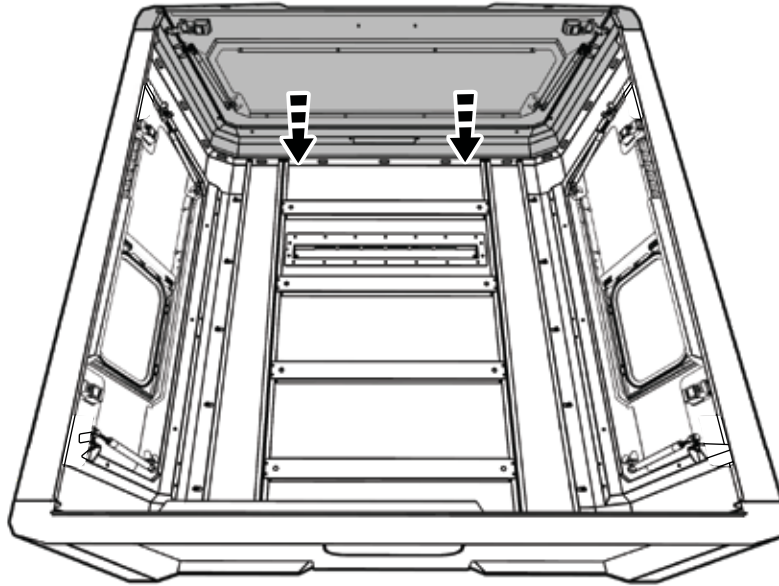

# STEP 18

INSTALL HARDWARE ALONG REAR FLANGE WITH BOLT ON INSIDE.



START AT CENTER OF THE REAR FLANGE AND WORK YOUR WAY OUTWARDS.

ADJUST LEFT AND RIGHT PANELS TO ALIGN THE FASTENER BLOCK HOLES.

HAND TIGHTEN ONLY.

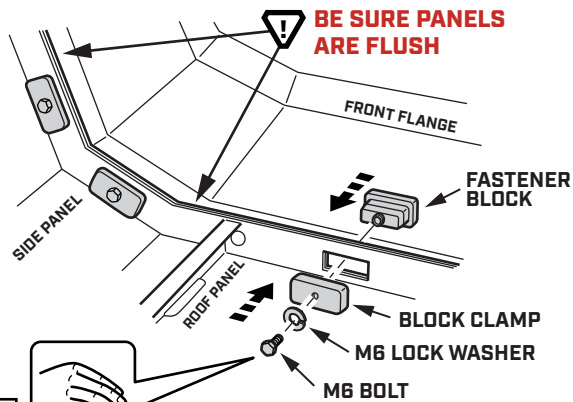

15X

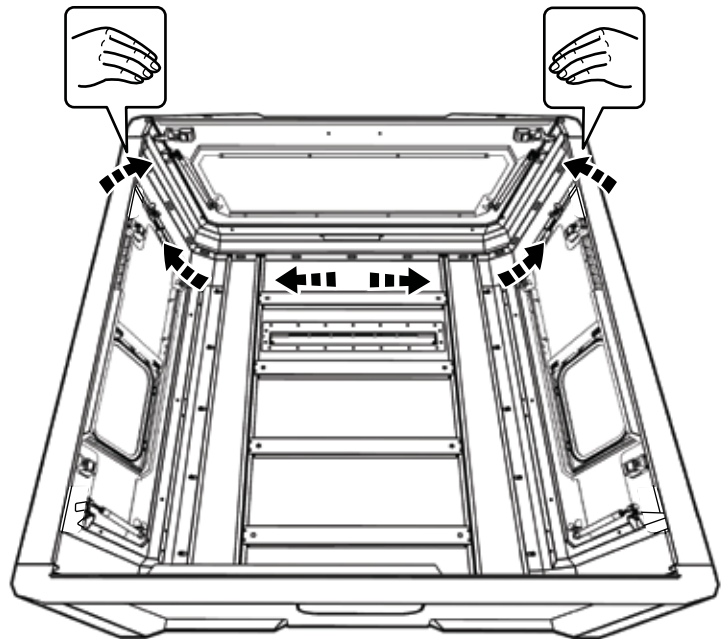

I-SHEET-NA-U3



# STEP 19

TIGHTEN ALL HARDWARE WITH TORQUE WRENCH AND 10MM SOCKET TO 3.7 FT. LBS. (5 NEWTON METERS)

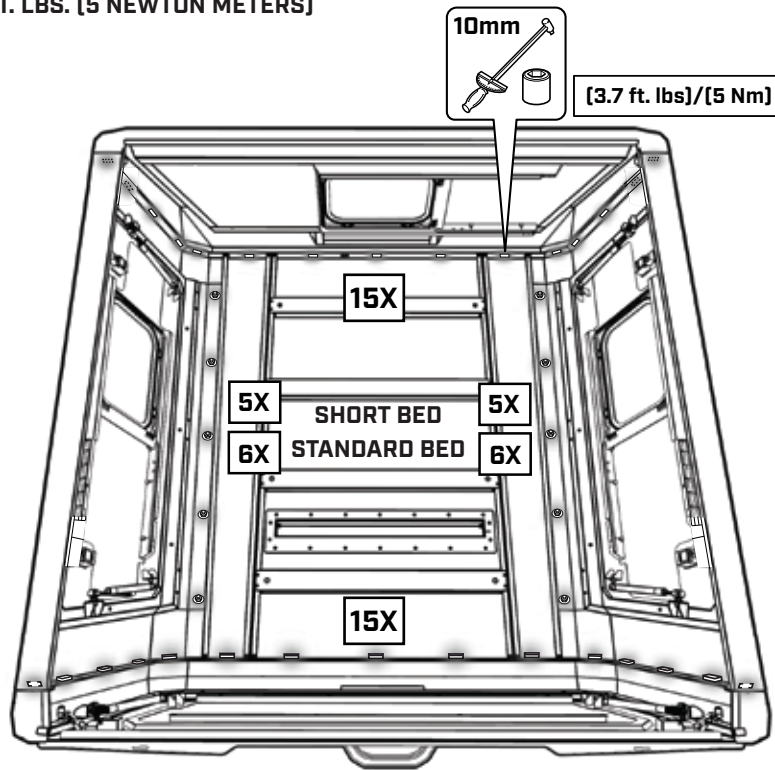

# STEP 20

ENSURE THE ENTIRE BOTTOM EDGE OF THE SMARTCAP IS CLEAN.

LOCATE BOTH RETENTION TABS ON THE REAR FLANGE AND BEND EACH TO A 45-DEGREE ANGLE FOR D-RUBBER FITMENT.

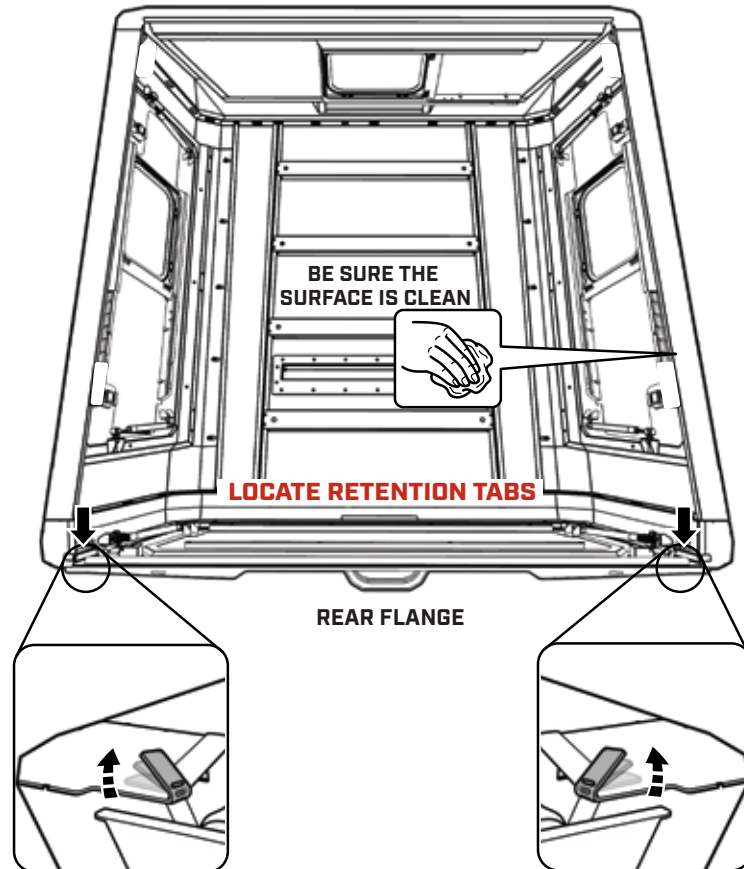

# STEP 21



TRIM THE D-RUBBER WITH A CLEAN, STRAIGHT CUT.

APPLY 2-3 INCHES SUPER GLUE NEAR THE RETENTION TABS, ALONG THE BOTTOM EDGE OF THE REAR FLANGE

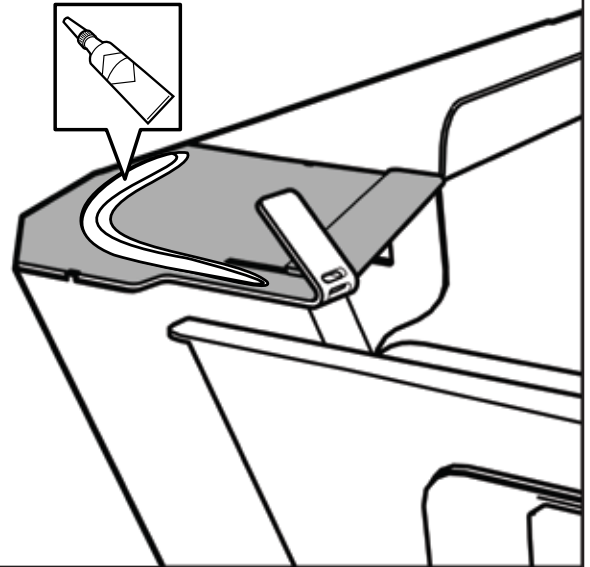
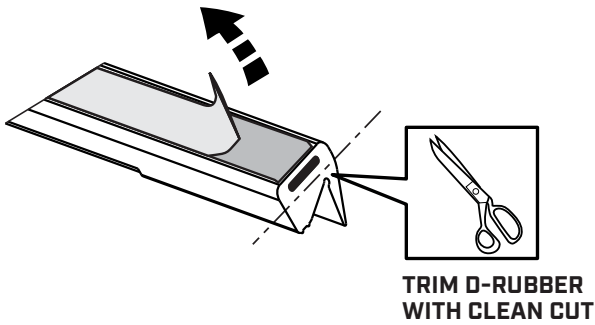

# STEP 22

FULLY INSERT THE RETENTION TAB INTO THE SLOT ON THE D-RUBBER. ENSURE THE D-RUBBER IS ORIENTED CORRECTLY WITH ITS PROFILE MATCHING THE CONTOUR OF THE REAR FLANGE.

PRESS DOWN FIRMLY ON THE TAB AND THE D-RUBBER TO BOND IT TO THE REAR FLANGE, CREATING A TIGHT SEAL.

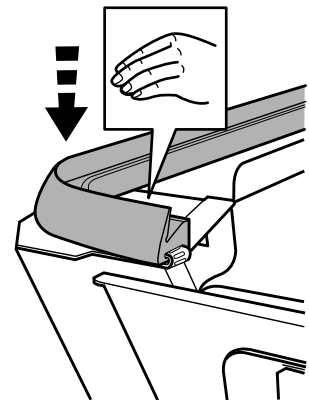
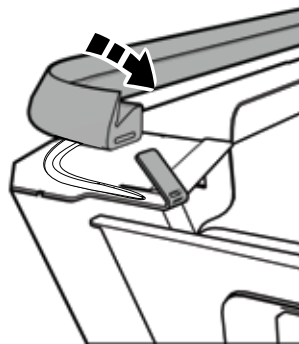

**CORRECT D-RUBBER ORIENTATION**

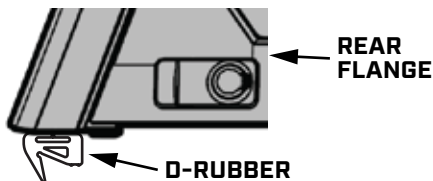

**INCORRECT D-RUBBER ORIENTATION**

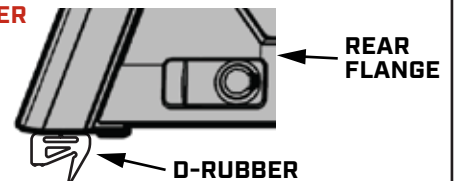

## STEP 23

ALIGN THE D-RUBBER ALONG THE SMARTCAP'S EDGE, MAINTAINING A CONSISTENT 1/8 INCH GAP FROM THE EDGE.

START FROM ONE CORNER AND WORK YOUR WAY AROUND THE CAP TO ENSURE PROPER PLACEMENT AND ALIGNMENT.

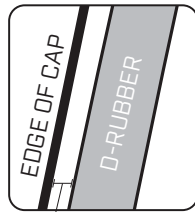

1/8 INCH  
FROM EDGE

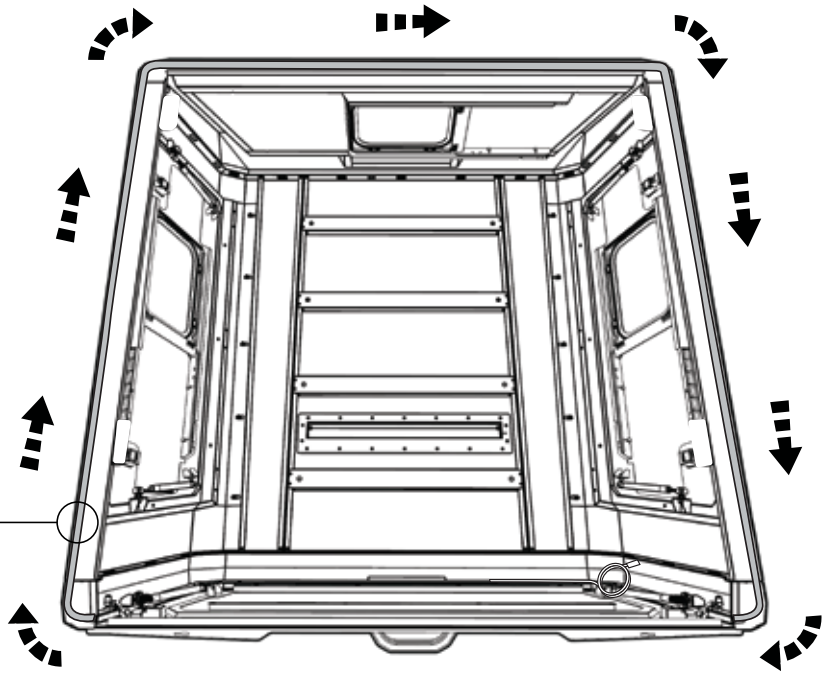

## STEP 24

TRIM ANY EXCESS D-RUBBER BEYOND THE EDGE FOR A NEAT FINISH.

APPLY 2-3 INCHES OF SUPER GLUE NEAR THE RETENTION TAB, ALONG THE BOTTOM EDGE OF THE REAR FLANGE. FULLY INSERT THE RETENTION TAB INTO THE SLOT ON THE D-RUBBER.

PRESS DOWN FIRMLY ON THE TAB AND THE D-RUBBER TO BOND IT TO THE REAR FLANGE, CREATING A TIGHT SEAL.



TRIM D-RUBBER  
WITH CLEAN CUT

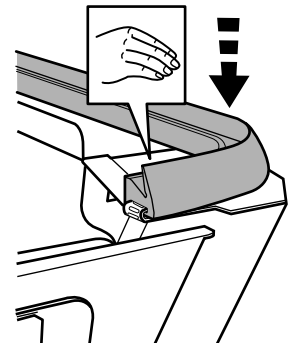
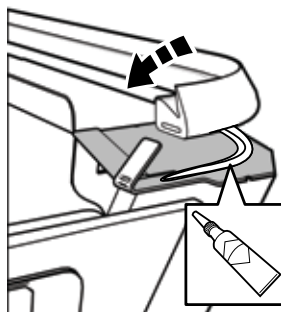
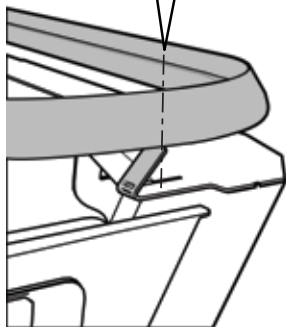

I-SHEET-NA-U3



# INSTALLATION HARDWARE

• **GM SILVERADO**  
2019-2020

• **GM COLORADO**  
2015-2022

• **JEEP GLADIATOR**  
[WITHOUT TRAIL RAIL]

• **RAM 1500 & HEAVY DUTY**  
2019-Current

• **FORD F-150**  
2015-2020

• **TOYOTA TUNDRA**  
[WITHOUT DECK RAIL]

THIN RUBBER PAD

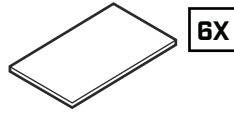

THICK RUBBER PAD

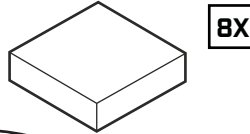

MOUNTING CLAMPS

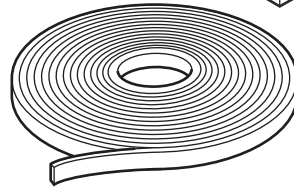
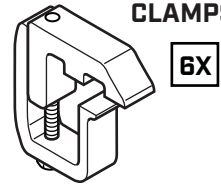

5mm  
FOAM SEAL TAPE

• **JEEP GLADIATOR**  
[WITH TRAIL RAIL]

• **TOYOTA TUNDRA**  
2007-2021  
[WITH DECK RAIL]

• **TOYOTA TACOMA**  
2005-2015

THIN RUBBER PAD

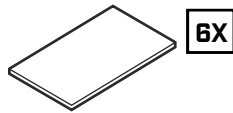

THICK RUBBER PAD

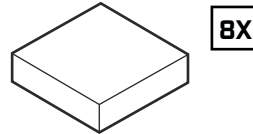

MOUNTING CLAMPS

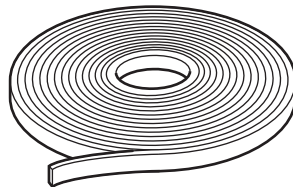
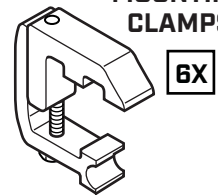

5mm  
FOAM SEAL TAPE

• **FORD RANGER**  
2019-2023

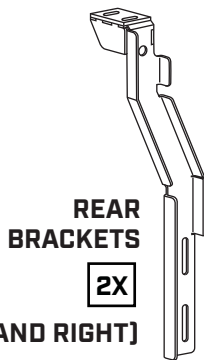

(LEFT AND RIGHT)

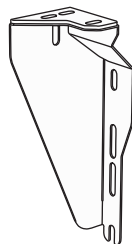

FRONT BRACKETS

2X

(LEFT AND RIGHT)

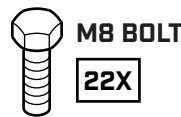

M8 BOLT

22X



M8 FENDER WASHER

30X



M8 LOCK WASHER

12X



M8 LOCK NUT

10X

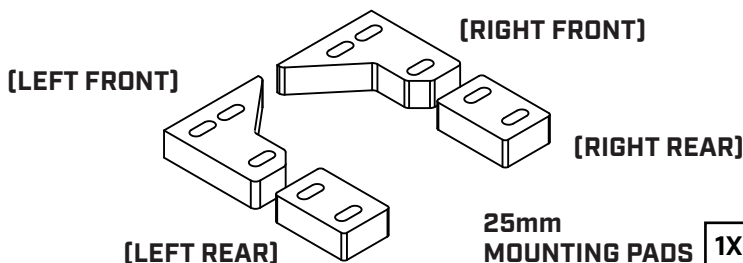

25mm  
MOUNTING PADS 1X

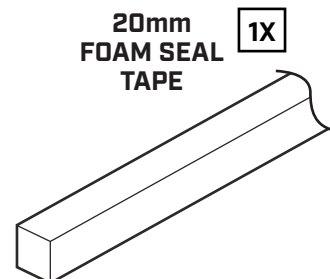

20mm  
FOAM SEAL TAPE 1X

## VEHICLE INSTALLATION



### IMPORTANT

- ▼ ASSISTANCE WILL BE NEEDED FOR THIS INSTALLATION. FOUR PEOPLE ARE RECOMMENDED TO LIFT THE SMARTCAP ONTO THE VEHICLE.
- ▼ AVOID PINCHING OR CRUSHING HANDS AND FINGERS.
- ▼ BE SURE THE VEHICLE IS TURNED OFF FOR THIS INSTALLATION.
- ▼ READ THROUGH THE ENTIRE PROCEDURE BEFORE STARTING AND FOLLOW THE STEPS CAREFULLY TO ENSURE THE THIRD BRAKE LIGHT WILL FUNCTION PROPERLY.
- ▼ USE A TEST LIGHT TO CHECK FOR SUCCESSFUL INSTALLATION.

## THIRD BRAKE LIGHT CONNECTOR INSTALLATION

- ▼ ONCE CAP INSTALLATION IS COMPLETE, CONTINUE TO PAGE 30 FOR THE THIRD BRAKE LIGHT INSTALLATION ON ALL VEHICLES EXCEPT TOYOTA TACOMA AND JEEP GLADIATOR.

# STEP 25-31

### GENERAL APPLICATION

- GM SILVERADO/SIERRA
- GM COLORADO/CANYON
- JEEP GLADIATOR
- RAM 1500 & 2500/3500
- FORD F-150
- TOYOTA TUNDRA

# STEP 32-50

### TOYOTA TACOMA

YOU WILL NEED THE T-HARNESS  
FOR THIS INSTALLATION

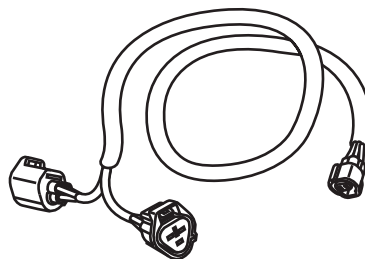

# STEP 51-64

### FORD RANGER

# STEP 25

## GENERAL APPLICATION

REMOVE THE ADHESIVE BACKING FROM THE THICK RUBBER PAD.

PLACE THE PADS ALONG THE INSIDE OF THE D-RUBBER AT THE INDICATED LOCATIONS.

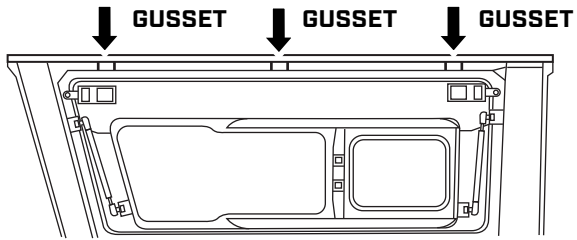
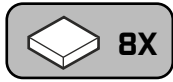

NOTE THE RECOMMENDED LOCATIONS FOR THE MOUNTING CLAMPS INSIDE BOTH SIDES OF THE SMARTCAP

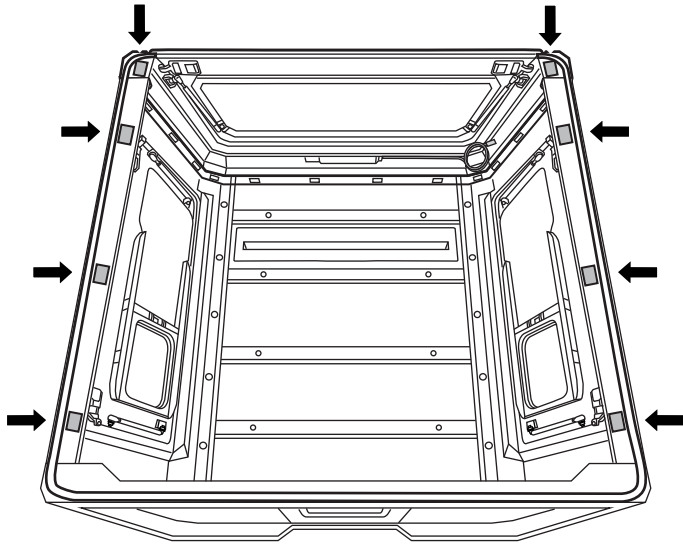

PLACE EXTRA PAD IN EACH REAR CORNER OF THE CAP

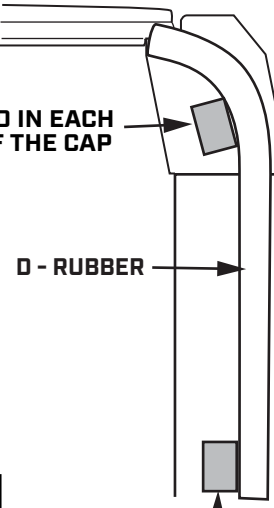

THICK RUBBER PAD

THICK RUBBER PAD

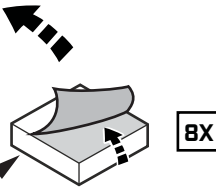

# STEP 26

## GENERAL APPLICATION

INSPECT THE TRUCK BED. IF FRONT EDGE IS LOWER THAN THE SIDES, ADD FOAM SEAL TAPE TO THE FRONT EDGE OF THE BED.

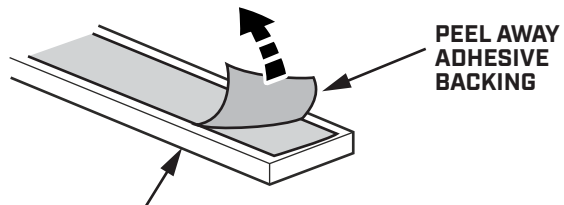
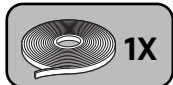

5mm FOAM SEAL TAPE

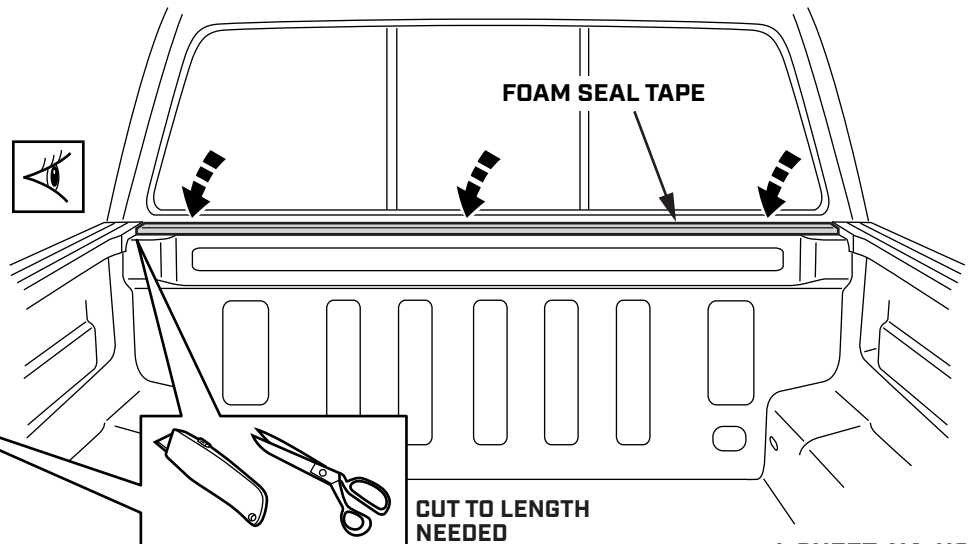

BE SURE TO FULLY SEAL AT BOTH ENDS

I-SHEET-NA-U3

## STEP 27

### GENERAL APPLICATION

USE 4 PEOPLE TO LIFT THE ASSEMBLED SMARTCAP ONTO THE TRUCK BED.

TO AVOID DAMAGE TO THE D-RUBBER, DO NOT SLIDE THE SMARTCAP INTO PLACE.

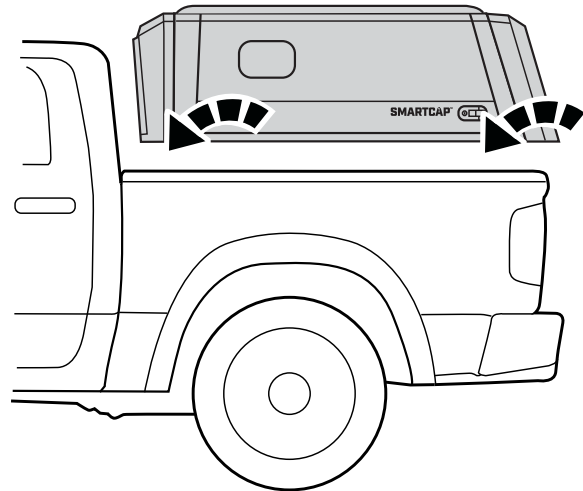
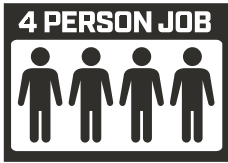

## STEP 28

### GENERAL APPLICATION

CHECK THAT THE SMARTCAP IS PROPERLY POSITIONED AND CENTERED ON THE TRUCK BED.

IT'S IMPORTANT THAT THE SMARTCAP IS NOT PUSHED TOO FAR FORWARD, LEAVING A GAP BETWEEN THE SMARTCAP AND THE CAB.

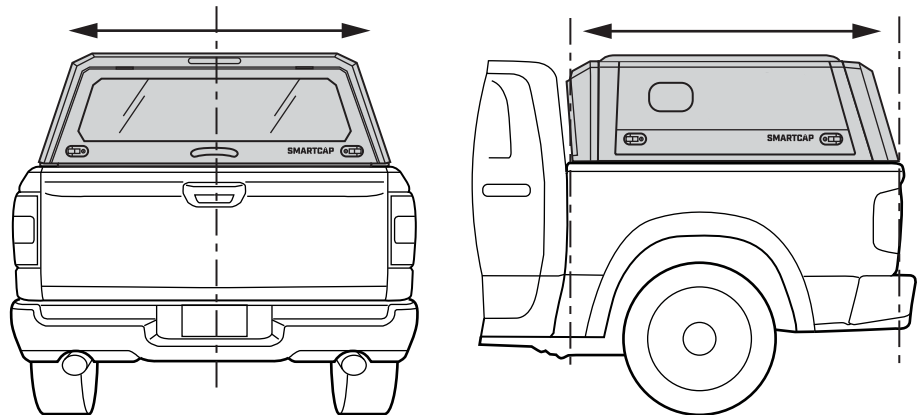
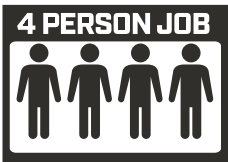

## STEP 29

### GENERAL APPLICATION

WALK AROUND THE TRUCK BED TO MAKE SURE THE D-RUBBER FITMENT IS CORRECT AND THAT THE RUBBER LIP IS PROPERLY TUCKED UNDERNEATH THE CAP.

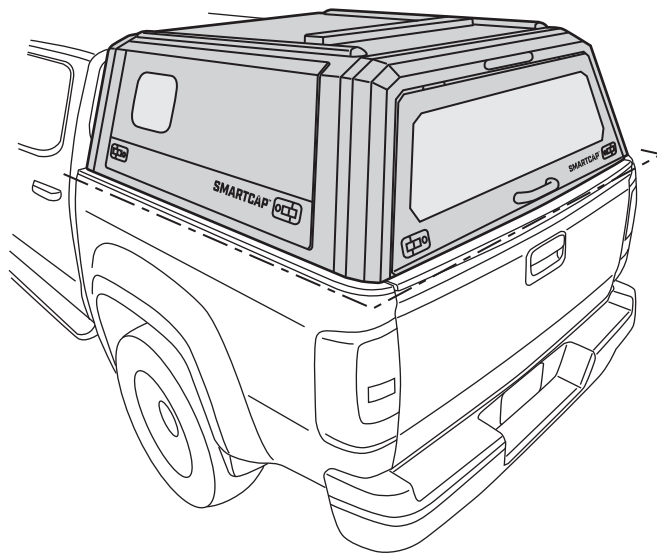

*\*YOU MAY NOTICE THAT THE SEAL ON THE SLIDING PORTAL WINDOW MIGHT APPEAR WRINKLED. THIS IS DUE TO THE ANTI-SLIP COATING AND IS NOT A CAUSE FOR CONCERN.*

I-SHEET-NA-U3

# STEP 30

## GENERAL APPLICATION

WITH THE EXCEPTION OF THE REAR CORNERS, PLACE THE THIN RUBBER PADS NEXT TO GUSSETS ON BOTH SIDES OF THE CAP.

**3 PADS PER SIDE**

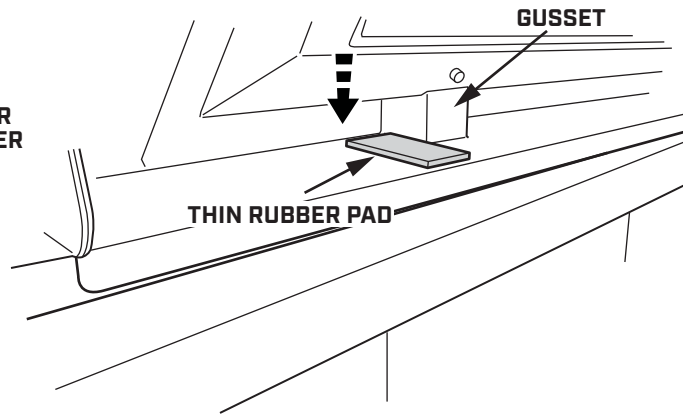

# STEP 31-A

## GENERAL APPLICATION WITHOUT DECK RAILS

ONCE ALL PADS ARE IN PLACE, INSTALL AND TIGHTEN MOUNTING CLAMPS USING TORQUE WRENCH AND 13MM SOCKET TO 4.4 FT. LBS. [6 NEWTON METERS]

**3 CLAMPS PER SIDE**

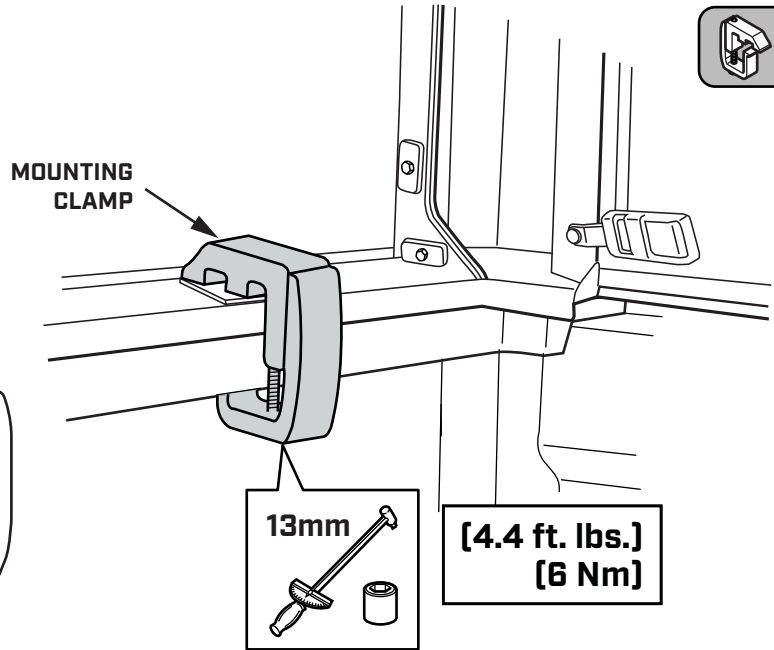
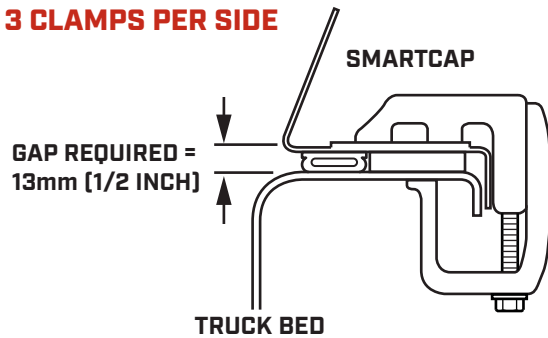

# STEP 31-B

**YOUR CAP INSTALLATION IS COMPLETE, CONTINUE TO PAGE 30 FOR THE THIRD BRAKE LIGHT INSTALLATION.**

## GENERAL APPLICATION WITH DECK RAILS

DISASSEMBLE MOUNTING CLAMPS.

INSTALL LOWER CLAMP ARMS INTO RAIL INSIDE TRUCK BED AND SET THEM IN FRONT OF EVERY THIN RUBBER PAD.

**3 CLAMPS PER SIDE**

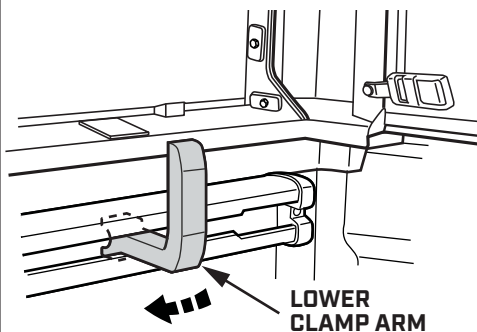

REASSEMBLE UPPER AND LOWER CLAMP ARMS.

HAND TIGHTEN ALL MOUNTING CLAMPS.

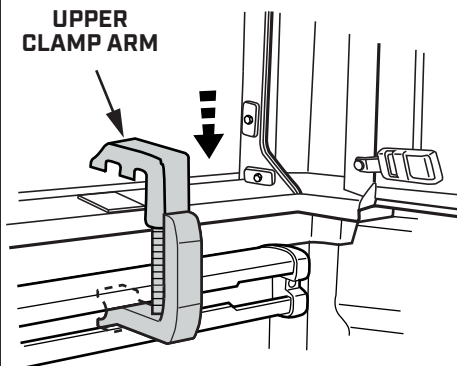

TIGHTEN MOUNTING CLAMPS USING TORQUE WRENCH AND 13MM SOCKET TO 4.4 FT. LBS. [6 NEWTON METERS]

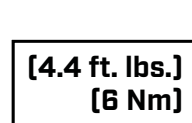
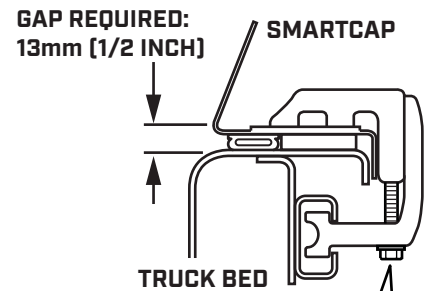

I-SHEET-NA-U3

# STEP 32

## TOYOTA TACOMA

REMOVE THE ADHESIVE BACKING FROM THE THICK RUBBER PAD.

PLACE THE PADS ALONG THE INSIDE OF THE D-RUBBER AT THE INDICATED LOCATIONS.

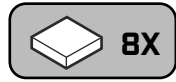
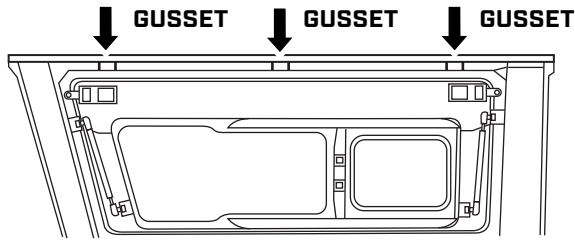
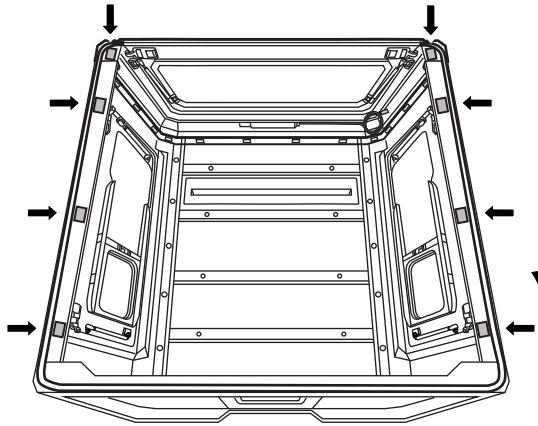

NOTE THE RECOMMENDED LOCATIONS FOR THE MOUNTING CLAMPS INSIDE BOTH SIDES OF THE SMARTCAP

PLACE EXTRA PAD IN EACH REAR CORNER OF THE CAP

D - RUBBER

THICK RUBBER PAD



# STEP 33

## TOYOTA TACOMA

INSPECT THE TRUCK BED. IF FRONT EDGE IS LOWER THAN THE SIDES, ADD FOAM SEAL TAPE TO THE FRONT EDGE OF THE BED.

5mm FOAM SEAL TAPE

PEEL AWAY ADHESIVE BACKING

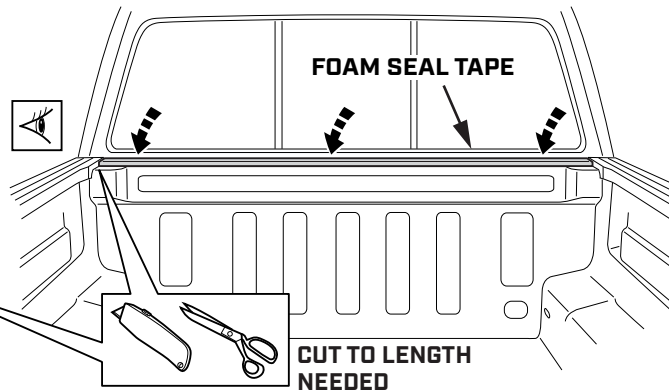
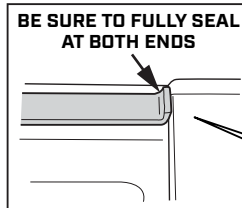
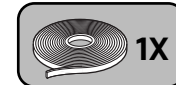

# STEP 34

## TOYOTA TACOMA

DISCONNECT THE EXTENSION HARNESS FROM THE SMARTCAP.

REAR FLANGE

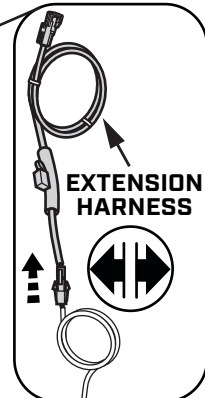
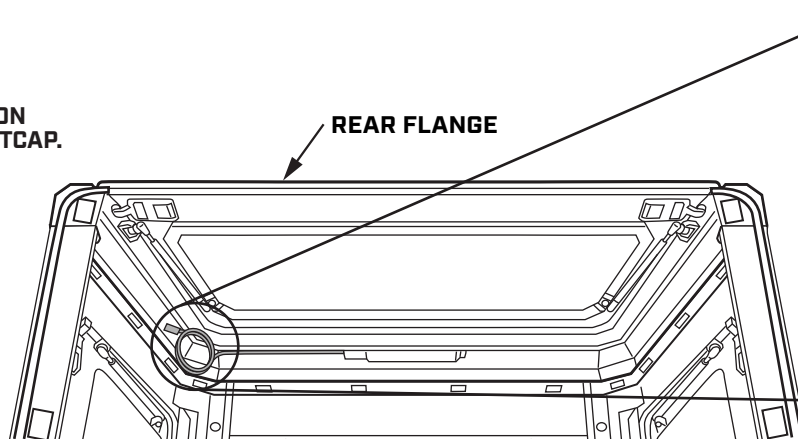

I-SHEET-NA-U3

## STEP 35

### TOYOTA TACOMA

REMOVE THE BOLTS HOLDING THE DRIVER SIDE TAILLIGHT ASSEMBLY.

TAILLIGHT ASSEMBLY

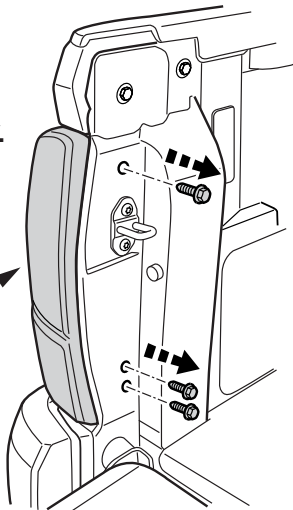

## STEP 36

### TOYOTA TACOMA

PLACE THE TAILLIGHT ASSEMBLY CAREFULLY ON THE TAILGATE. DO NOT UNPLUG ANY CONNECTORS.

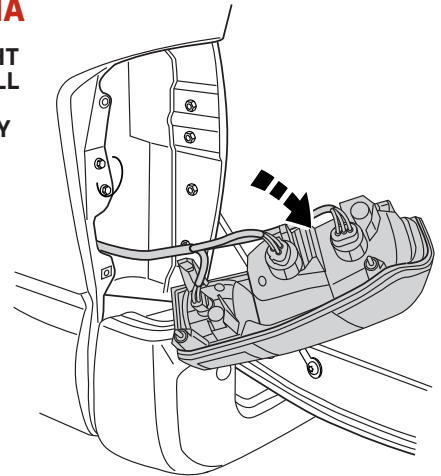

## STEP 37

### TOYOTA TACOMA

CAREFULLY PULL UP ON THE TOP EDGE PANEL OF THE TRUCK BED TO LOCATE THE HOLE IN THE SHEET METAL.

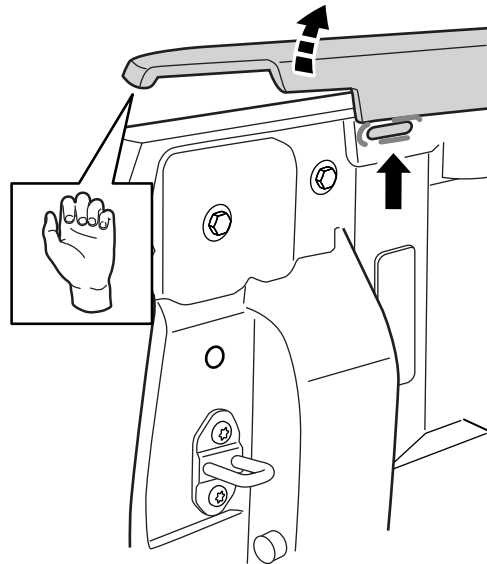

## STEP 38

### TOYOTA TACOMA

ROUTE THE EXTENSION HARNESS THROUGH THE HOLE AND BACK TOWARDS THE TAILLIGHT OPENING.

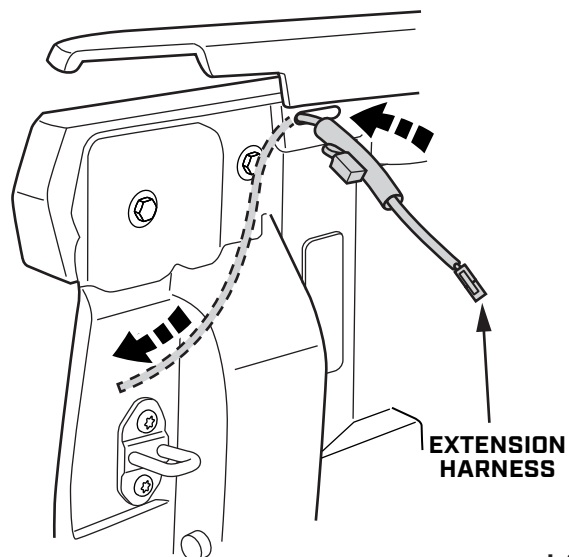

I-SHEET-NA-U3



# STEP 39

## TOYOTA TACOMA

DISCONNECT THE MIDDLE BRAKE LIGHT PLUG AT THE BACK OF THE TAILLIGHT ASSEMBLY.

TAILLIGHT CAVITY

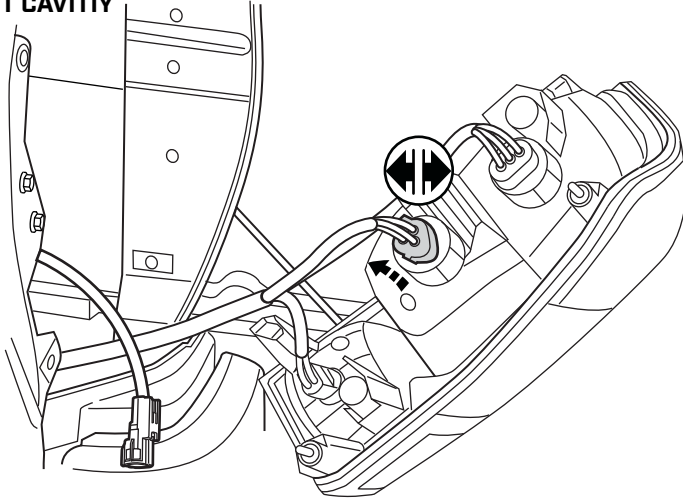

# STEP 40

## TOYOTA TACOMA

CONNECT THE BRAKE LIGHT PLUG INTO THE FEMALE PLUG FROM THE T-HARNESS.

CONNECT THE MALE PLUG FROM THE T-HARNESS INTO THE FEMALE BRAKE LIGHT SOCKET.

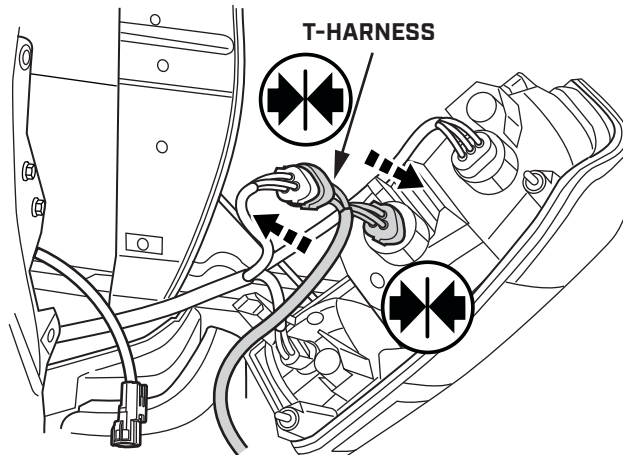
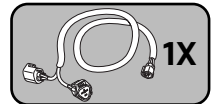

# STEP 41

## TOYOTA TACOMA

CONNECT THE T-HARNESS TO THE EXTENSION HARNESS.

EXTENSION HARNESS

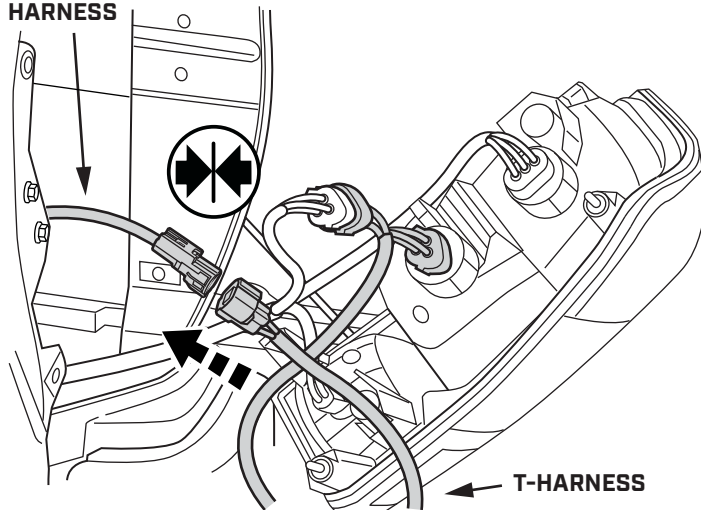

I-SHEET-NA-U3

## STEP 42

### TOYOTA TACOMA

BUNDLE EXTRA T-HARNESS LENGTH IN THE TAILLIGHT CAVITY AND SECURE WITH CABLE TIES.

REINSTALL THE TAILLIGHT ASSEMBLY.

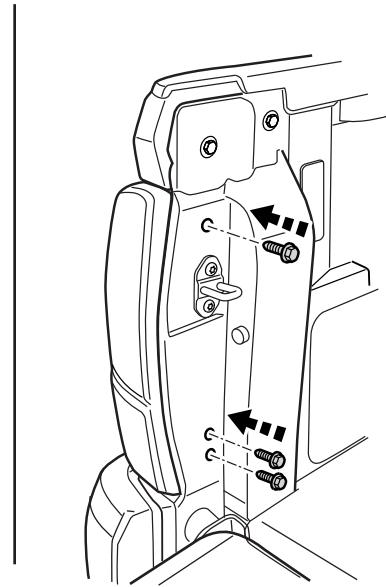
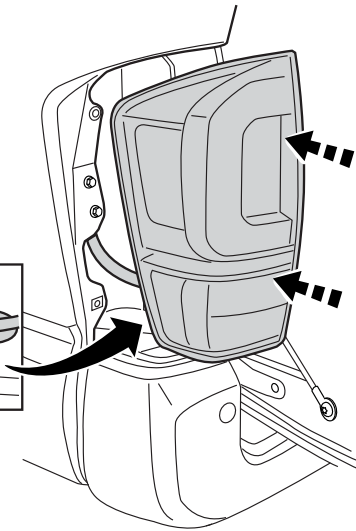
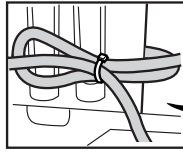

## STEP 43

### TOYOTA TACOMA

USE 4 PEOPLE TO LIFT THE ASSEMBLED SMARTCAP ONTO THE TRUCK BED.

TO AVOID DAMAGE TO THE D-RUBBER, DO NOT SLIDE THE SMARTCAP INTO PLACE.

4 PERSON JOB

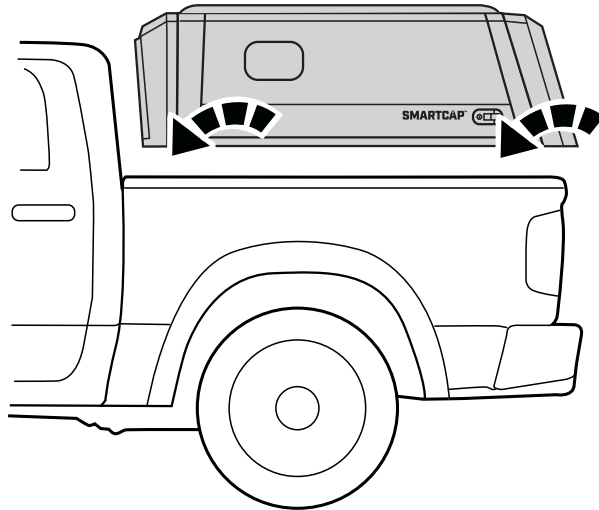

## STEP 44

### TOYOTA TACOMA

CHECK THAT THE SMARTCAP IS PROPERLY POSITIONED AND CENTERED ON THE TRUCK BED.

IT'S IMPORTANT THAT THE SMARTCAP IS NOT PUSHED TOO FAR FORWARD, LEAVING A GAP BETWEEN THE SMARTCAP AND THE CAB.

4 PERSON JOB

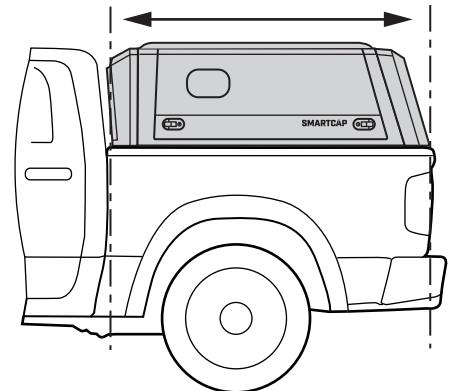
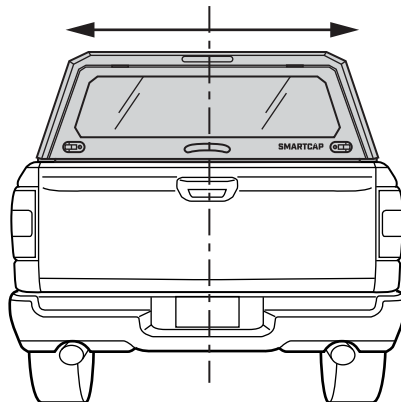

# STEP 45

## TOYOTA TACOMA

WALK AROUND THE TRUCK BED TO MAKE SURE THE D-RUBBER FITMENT IS CORRECT AND THAT THE RUBBER LIP IS PROPERLY TUCKED UNDERNEATH THE CAP.

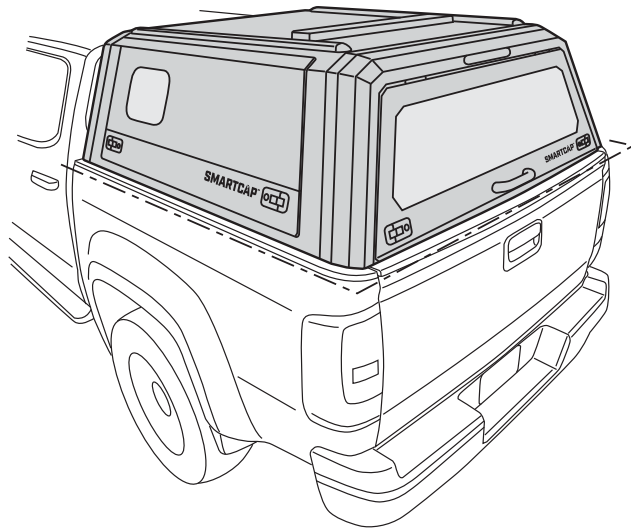

*\*YOU MAY NOTICE THAT THE SEAL ON THE SLIDING PORTAL WINDOW MIGHT APPEAR WRINKLED. THIS IS DUE TO THE ANTI-SLIP COATING AND IS NOT A CAUSE FOR CONCERN.*

# STEP 46

## TOYOTA TACOMA

WITH THE EXCEPTION OF THE REAR CORNERS, PLACE THE THIN RUBBER PADS NEXT TO GUSSETS ON BOTH SIDES OF THE CAP.

**3 PADS PER SIDE**

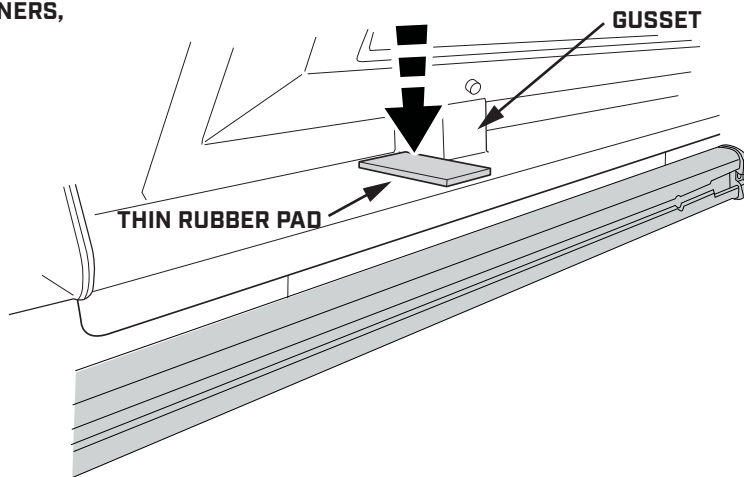

# STEP 47

## TOYOTA TACOMA

DISASSEMBLE MOUNTING CLAMPS.

INSTALL LOWER CLAMP ARMS INTO RAIL INSIDE TRUCK BED AND SET THEM IN FRONT OF EVERY THIN RUBBER PAD.

**3 CLAMPS PER SIDE**

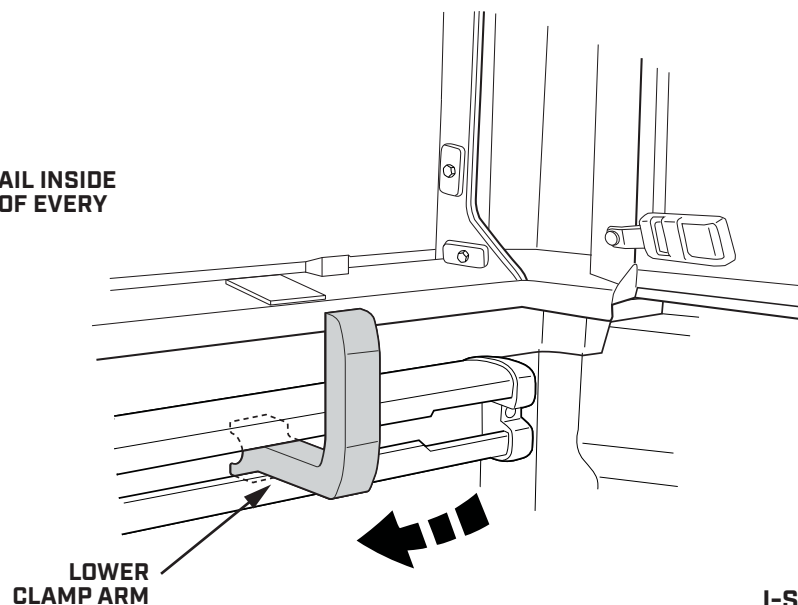

I-SHEET-NA-U3

## STEP 48

### TOYOTA TACOMA

REASSEMBLE UPPER AND LOWER CLAMP ARMS.

HAND TIGHTEN ALL MOUNTING CLAMPS.

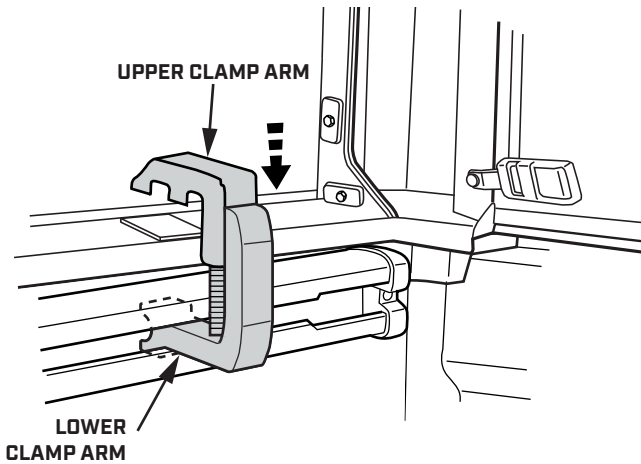

TIGHTEN MOUNTING CLAMPS USING TORQUE WRENCH AND 13MM SOCKET TO 4.4 FT. LBS. [6 NEWTON METERS]

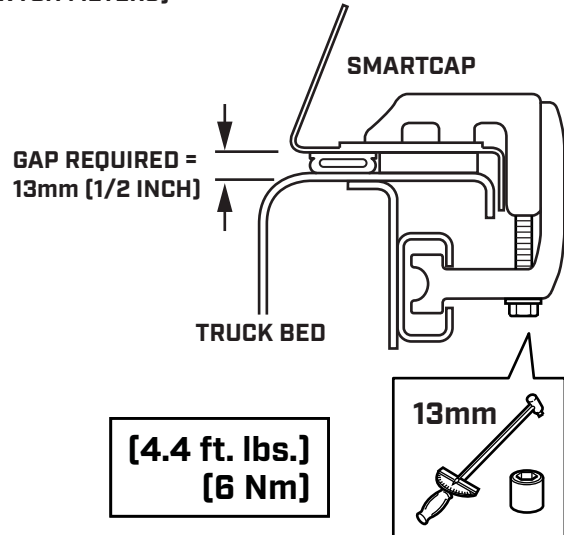

## STEP 49

### TOYOTA TACOMA

CONNECT THE EXTENSION HARNESS TO THE SMARTCAP'S THIRD BRAKE LIGHT HARNESS.

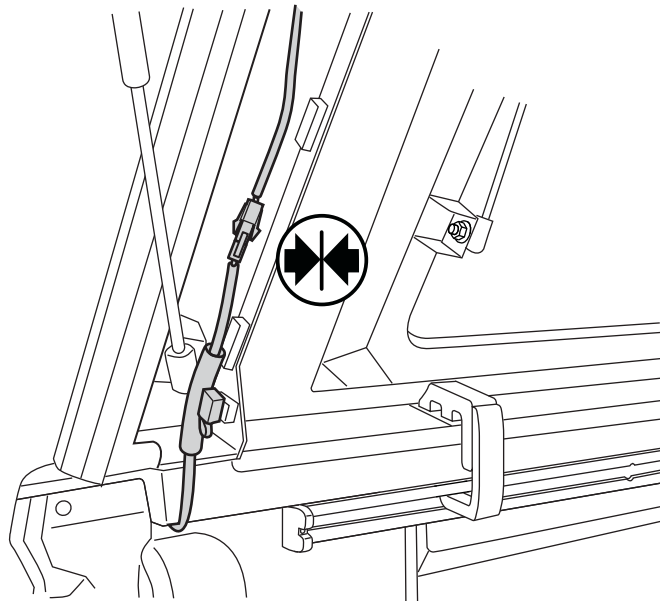

## STEP 50



### TEST YOUR BRAKE LIGHTS & TURN SIGNALS

- ▼ START THE TRUCK. SOME MODELS MAY TAKE UP TO 30 SECONDS FOR THE VEHICLE TO DETECT THE NEW CONNECTION.
- ▼ CHECK THE BRAKE LIGHTS AND TURN SIGNALS TO BE SURE THEY ARE FUNCTIONING PROPERLY.
- ▼ ONCE YOU HAVE CONFIRMED THAT THE LIGHTS ARE WORKING CORRECTLY, SECURE THE HARNESS WITH CABLE TIES.
- ▼ BE SURE NOT TO INTERFERE WITH ANY MOVING PARTS ON THE VEHICLE.
- ▼ YOU CAP INSTALLATION IS COMPLETE. YOU CAN FIND SMARTCAP CONTACT INFORMATION ON PAGE 39.

# STEP 51

## FORD RANGER

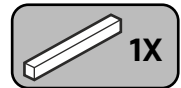

INSPECT THE TRUCK BED. IF FRONT EDGE IS LOWER THAN THE SIDES, ADD FOAM SEAL TAPE TO THE FRONT EDGE OF THE BED.

20mm FOAM SEAL TAPE

PEEL AWAY ADHESIVE BACKING

FOAM SEAL TAPE

BE SURE TO FULLY SEAL AT BOTH ENDS

CUT TO LENGTH NEEDED

# STEP 52

## FORD RANGER

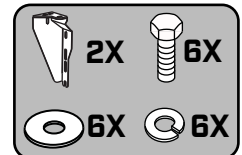

REMOVE THE FRONT TIE DOWN HOOK FROM THE INNER WALL OF THE TRUCK BED.

HAND TIGHTEN LEFT AND RIGHT FRONT MOUNTING BRACKETS TO THE TRUCK BED WITH M8 BOLT, M8 LOCK WASHER, TIE DOWN HOOK AND M8 FENDER WASHER AS SHOWN.

FRONT MOUNTING BRACKET

M8 FENDER WASHER

M8 LOCK WASHER

M8 BOLT

I-SHEET-NA-U3

# STEP 53

## FORD RANGER

REMOVE THE REAR TIE DOWN HOOK FROM THE INNER WALL OF THE TRUCK BED.

HAND TIGHTEN LEFT AND RIGHT REAR MOUNTING BRACKETS TO THE TRUCK BED WITH M8 BOLT, M8 LOCK WASHER, TIE DOWN HOOK AND M8 FENDER WASHER AS SHOWN.

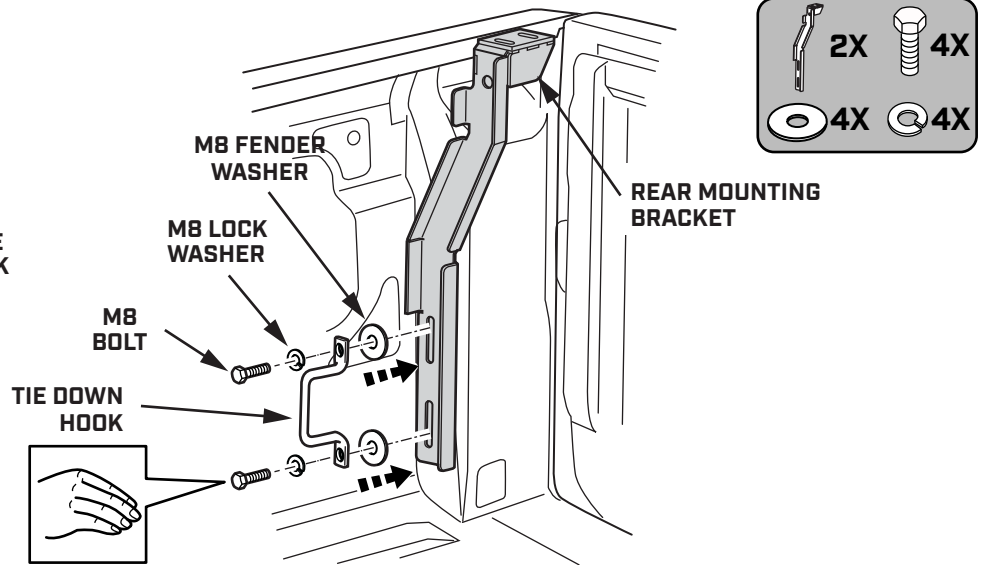

# STEP 54

## FORD RANGER

POSITION THE FRONT MOUNTING PADS ON TOP OF LEFT AND RIGHT FRONT MOUNTING BRACKETS AS SHOWN.

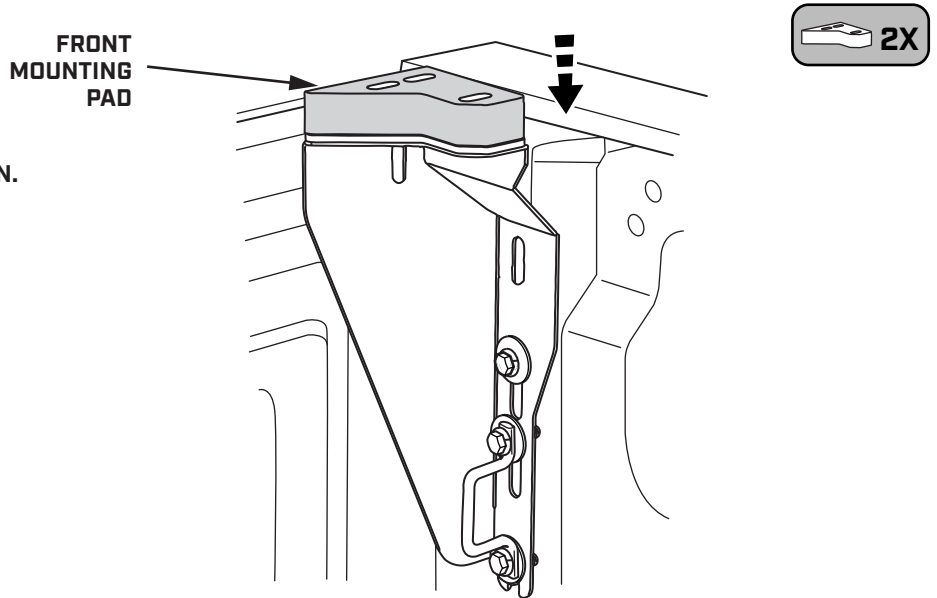

# STEP 55

## FORD RANGER

POSITION THE REAR MOUNTING PADS ON TOP OF LEFT AND RIGHT REAR MOUNTING BRACKETS AS SHOWN.

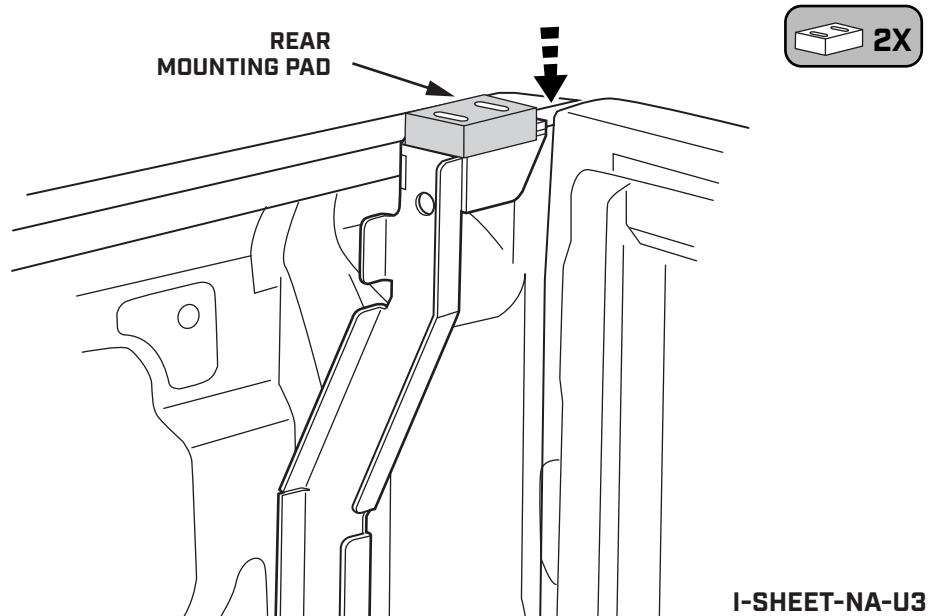

# STEP 56

## FORD RANGER

USE 4 PEOPLE TO LIFT THE ASSEMBLED SMARTCAP ONTO THE TRUCK BED.

TO AVOID DAMAGE TO THE D-RUBBER, DO NOT SLIDE THE SMARTCAP INTO PLACE.

4 PERSON JOB

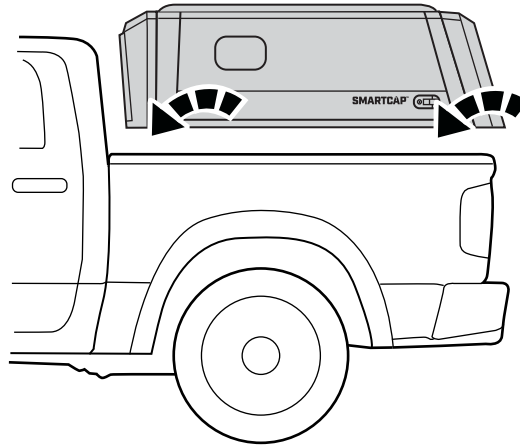

# STEP 57

## FORD RANGER

CHECK THAT THE SMARTCAP IS PROPERLY POSITIONED AND CENTERED ON THE TRUCK BED.

IT'S IMPORTANT THAT THE SMARTCAP IS NOT PUSHED TOO FAR FORWARD, LEAVING A GAP BETWEEN THE SMARTCAP AND THE CAB.

4 PERSON JOB

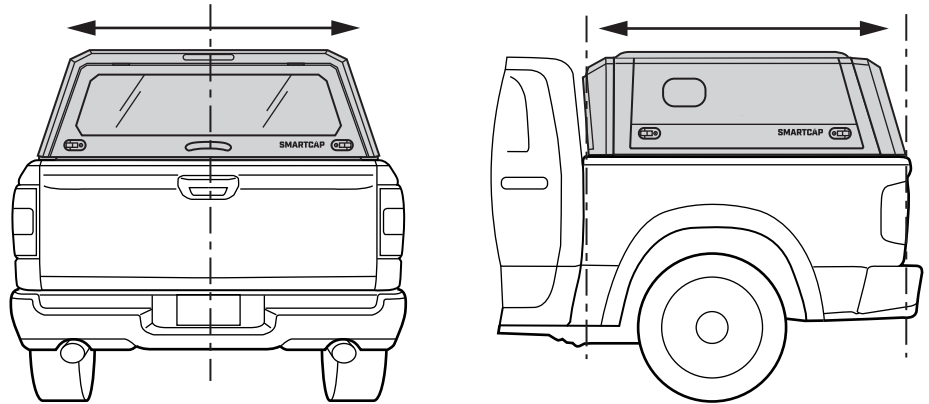

# STEP 58

## FORD RANGER

WALK AROUND THE TRUCK BED TO MAKE SURE THE D-RUBBER FITMENT IS CORRECT AND THAT THE RUBBER LIP IS PROPERLY TUCKED UNDERNEATH THE CAP.

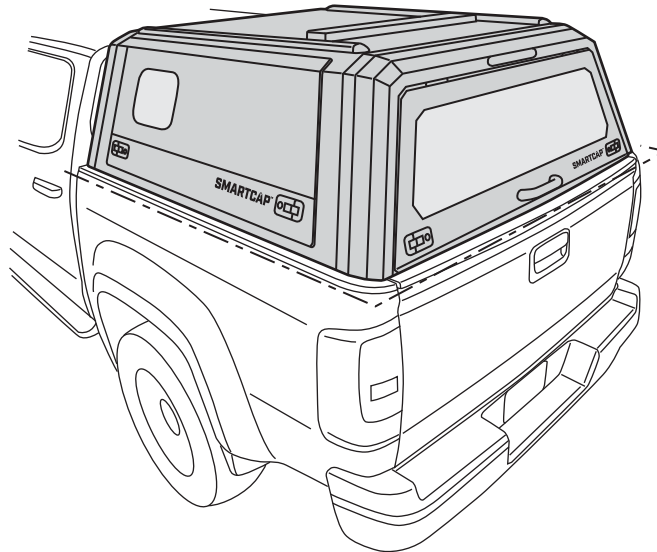

\*YOU MAY NOTICE THAT THE SEAL ON THE SLIDING PORTAL WINDOW MIGHT APPEAR WRINKLED. THIS IS DUE TO THE ANTI-SLIP COATING AND IS NOT A CAUSE FOR CONCERN.



# STEP 59

## FORD RANGER

SECURE LEFT AND RIGHT FRONT MOUNTING BRACKETS TO THE SMARTCAP USING M8 BOLTS, M8 FENDER WASHERS AND M8 LOCK NUTS AS SHOWN, HAND TIGHTEN ONLY.

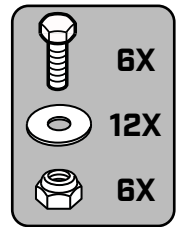
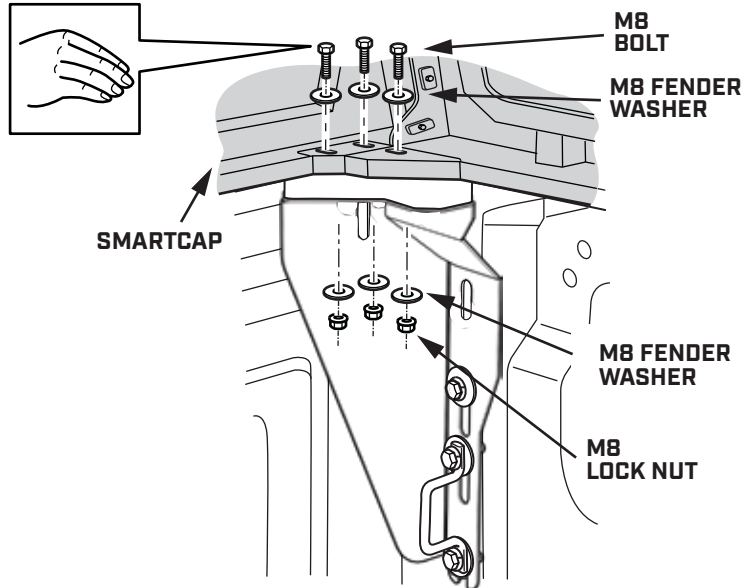

# STEP 60

## FORD RANGER

SECURE LEFT AND RIGHT REAR MOUNTING BRACKETS TO THE SMARTCAP USING M8 BOLTS, M8 FENDER WASHERS AND M8 LOCK NUTS AS SHOWN, HAND TIGHTEN ONLY.

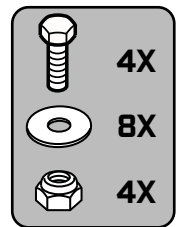
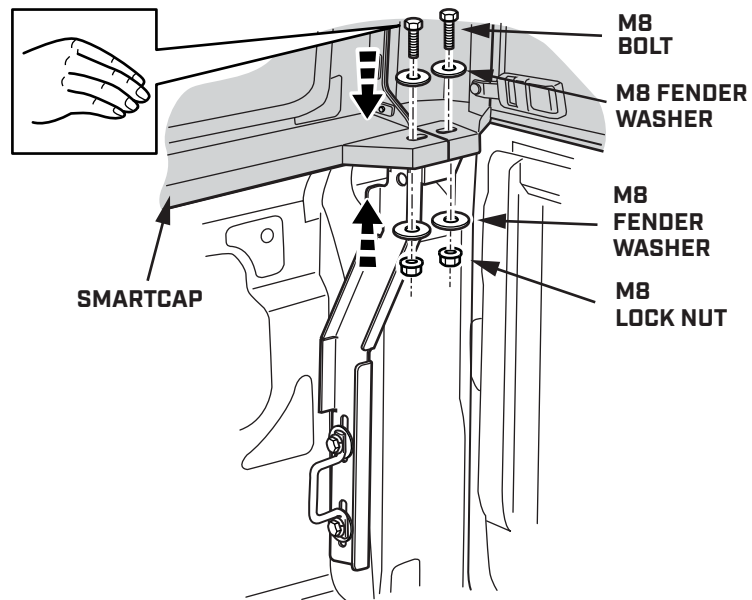

# STEP 61

## FORD RANGER

PARTIALLY TIGHTEN FASTENERS FOR ALL MOUNTING BRACKETS USING THE SOCKET WRENCH AND 13MM SOCKET.

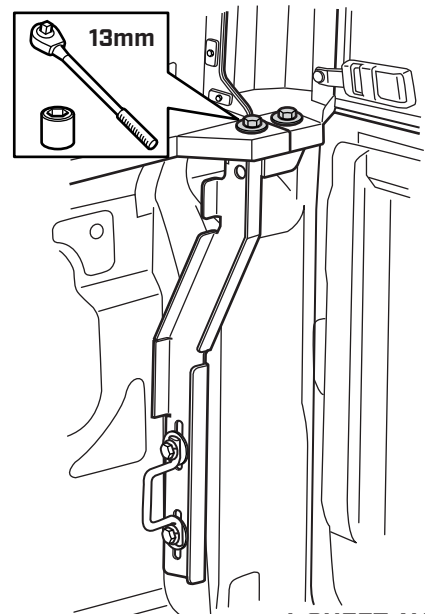
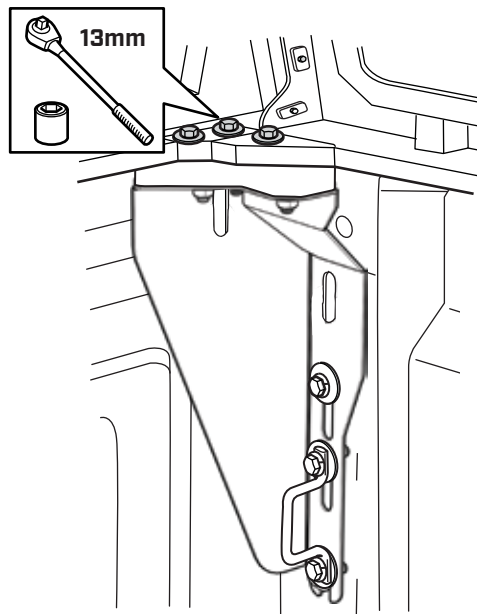

# STEP 62

## FORD RANGER

PRESS DOWN ON THE SMARTCAP TO ACHIEVE 2MM - 3MM COMPRESSION ON D-RUBBER AND PARTIALLY TIGHTEN ALL BRACKET FASTENERS ON ALL FOUR CORNERS WITH SOCKET WRENCH AND 13MM SOCKET.

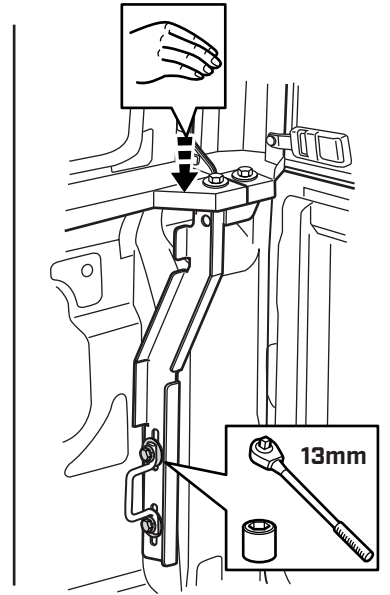
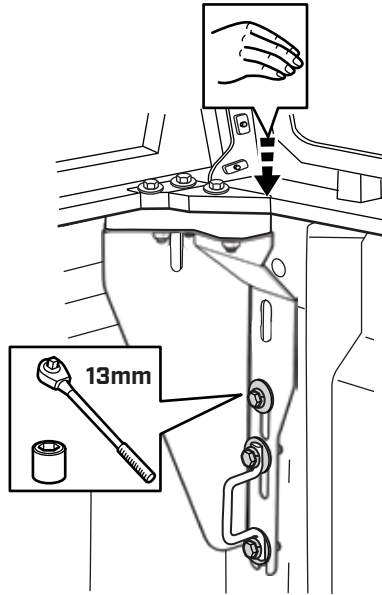
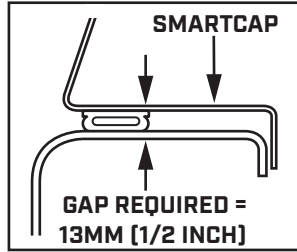

# STEP 63

## FORD RANGER

FULLY TIGHTEN ALL BRACKET FASTENERS ON ALL FOUR CORNERS TO THE SMARTCAP WITH A TORQUE WRENCH AND 13MM SOCKET TO 4.4 FT. LBS. OF TORQUE (6 NEWTON METERS).

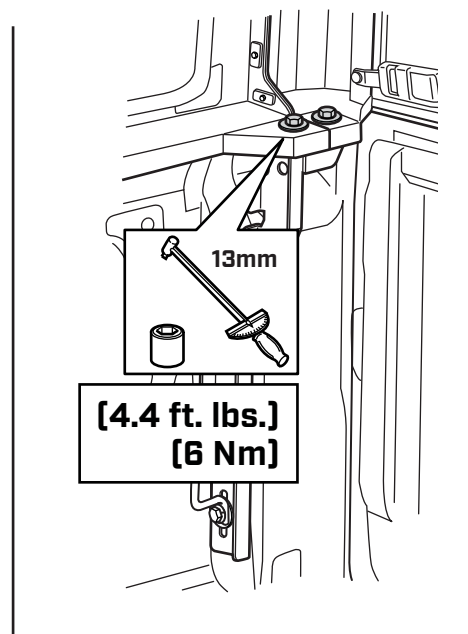
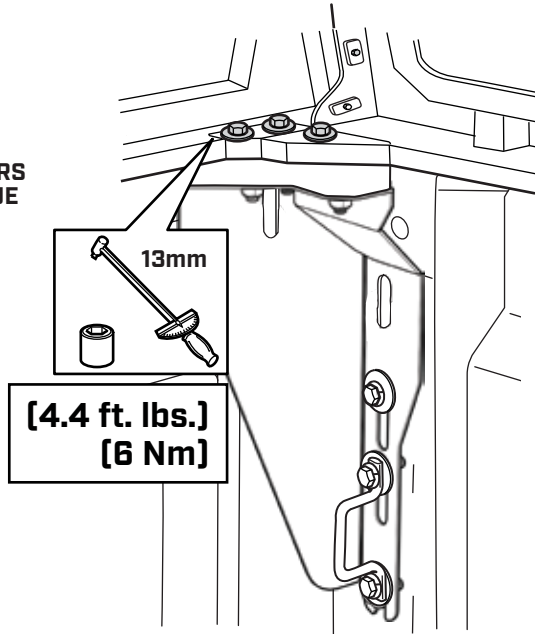

# STEP 64

## FORD RANGER

FULLY TIGHTEN BRACKET FASTENERS ON ALL FOUR CORNERS TO THE TRUCK BED WITH A TORQUE WRENCH AND 13MM SOCKET TO 9 FT. LBS. OF TORQUE (12.2 NEWTON METERS).

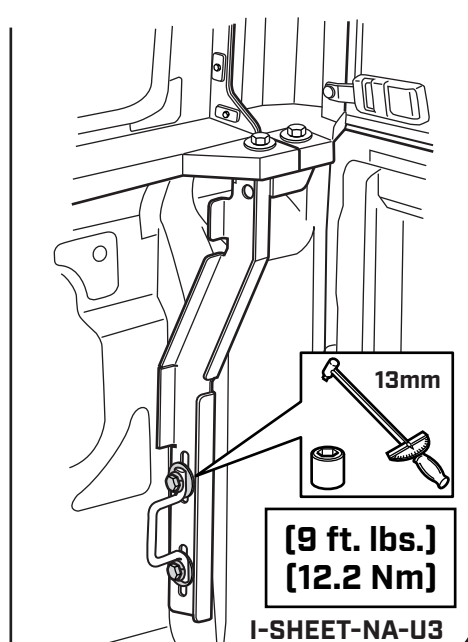
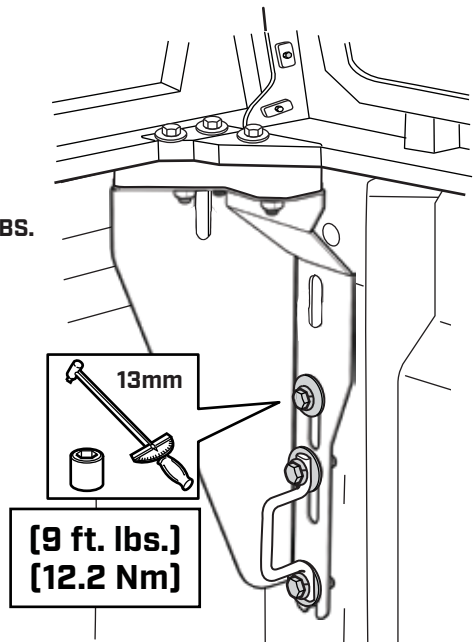

I-SHEET-NA-U3

## THIRD BRAKE LIGHT CONNECTOR INSTALLATION



### IMPORTANT

- ▼ BE SURE THE VEHICLE IS TURNED OFF FOR THIS INSTALLATION.
- ▼ READ THROUGH THE ENTIRE PROCEDURE BEFORE STARTING AND FOLLOW THE STEPS CAREFULLY TO ENSURE THE THIRD BRAKE LIGHT AND TRAILER PLUG WILL FUNCTION PROPERLY.
- ▼ USE A TEST LIGHT TO CHECK FOR SUCCESSFUL INSTALLATION.

▼ IF YOU DO NOT SEE YOUR MAKE/MODEL DETAILED BELOW PLEASE REACH OUT TO OUR SUPPORT TEAM FOR MORE INFORMATION AT [SUPPORT.NA@SMARTCAP.COM](mailto:SUPPORT.NA@SMARTCAP.COM)

## STEP 65-70

### WITH 7-WAY CONNECTOR

- GM COLORADO/CANYON (2015-2022)
- RAM 1500 & 2500/3500 (2019-2024)
- TOYOTA TUNDRA (2007-2021)

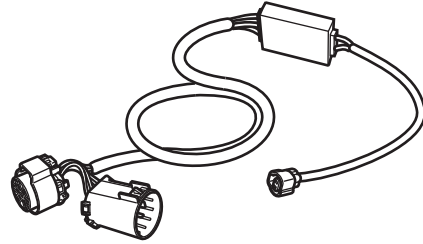

## STEP 71-76

### WITHOUT 7-WAY CONNECTOR

- GM SILVERADO/SIERRA 1500 (2019-2023)
- FORD F-150 (2015-2020)
- GM COLORADO (2023)

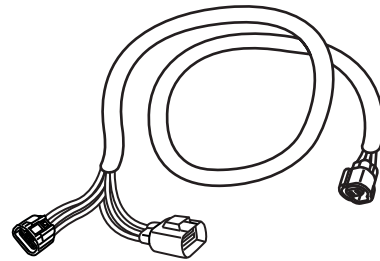

## STEP 77-88

- FORD RANGER (2019-2022)

### LED TAIL LIGHT HARNESS

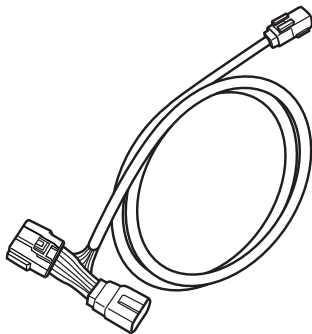

INCLUDED IN FITMENT KIT

### INCANDESCENT TAIL LIGHT HARNESS

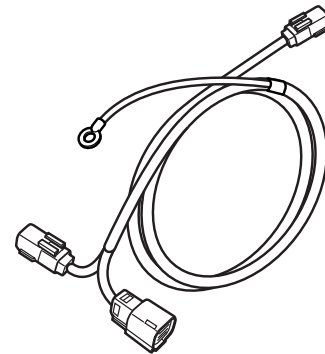

IF YOUR RANGER IS EQUIPPED WITH INCANDESCENT TAILLIGHTS, TO RECEIVE THE APPROPRIATE HARNESS, CONTACT [SUPPORT.NA@SMARTCAP.COM](mailto:SUPPORT.NA@SMARTCAP.COM)

I-SHEET-NA-U3

## STEP 65

### WITH 7-WAY CONNECTOR

LOCATE THE 7-WAY TRAILER CONNECTOR AT THE HITCH OR INSIDE THE BUMPER.

DISCONNECT THE PLUG FROM THE BACK OF THE 7-WAY CONNECTOR.

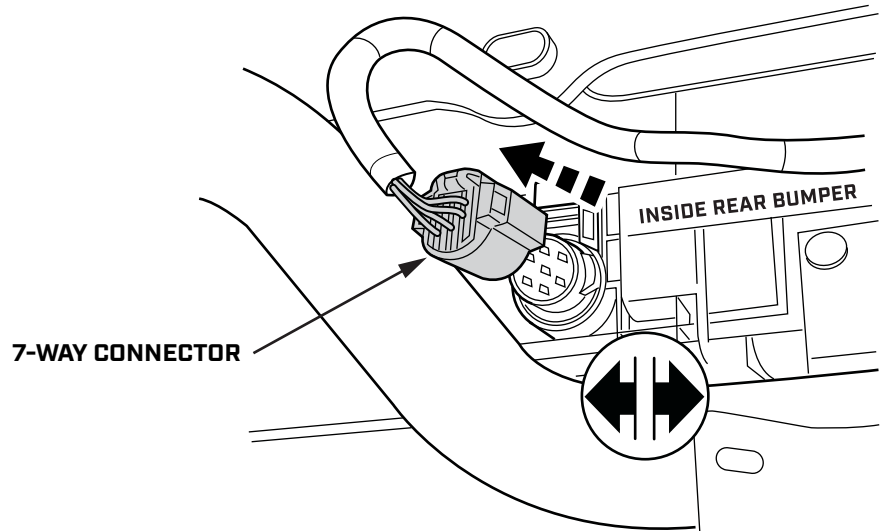

## STEP 66

### WITH 7-WAY CONNECTOR

PLUG THE NEW T-HARNESS INTO THE BACK OF THE 7-WAY CONNECTOR.

CONNECT THE ORIGINAL PLUG INTO THE FEMALE SIDE OF THE T-HARNESS.

BE SURE PLUGS ARE FULLY INSERTED AND LOCKING TABS ARE IN PLACE.

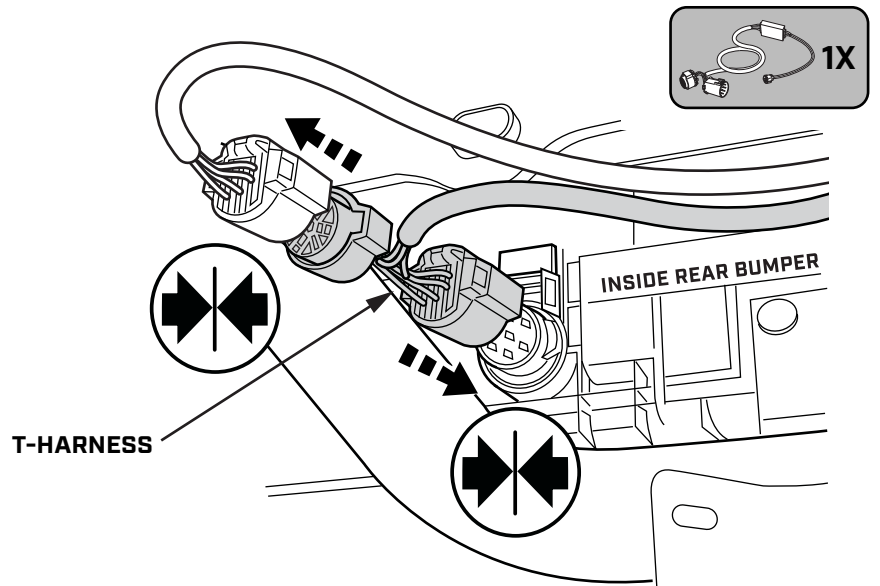

## STEP 67

### WITH 7-WAY CONNECTOR

UNTIE THE THIRD BRAKE LIGHT EXTENSION HARNESS FROM WHERE IT IS ATTACHED TO THE SMARTCAP AT THE RIGHT LEFT CORNER.

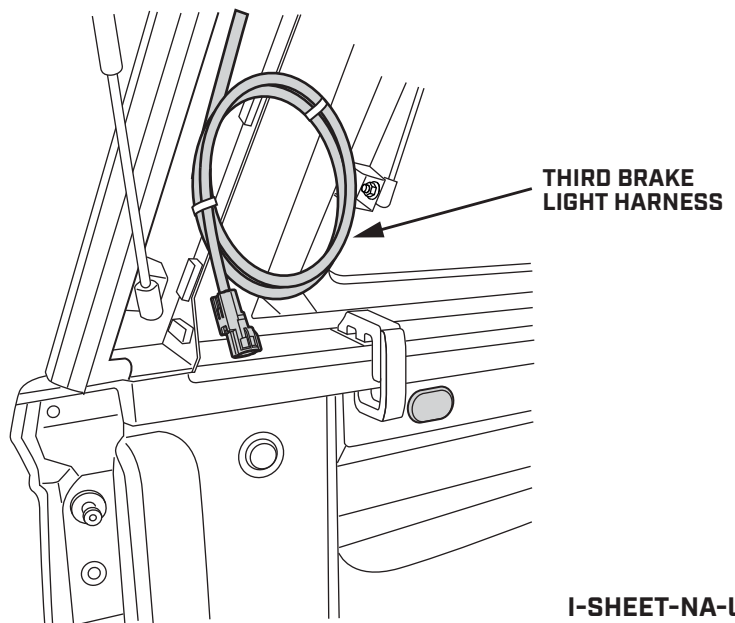

I-SHEET-NA-U3

## STEP 68

### WITH 7-WAY CONNECTOR

REMOVE THE GROMMET COVER AT THE TRUCK BED WALL.

ROUTE THE THIRD BRAKE LIGHT HARNESS IN THROUGH THE GROMMET OPENING AND DOWN TOWARDS THE REAR BUMPER..

THIRD BRAKE LIGHT HARNESS

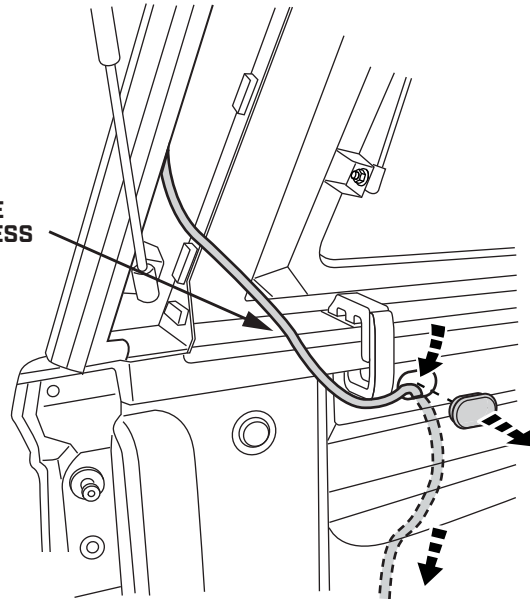

## STEP 69

### WITH 7-WAY CONNECTOR

ROUTE THE T-HARNESS ALONG THE INSIDE OF THE REAR BUMPER WITH THE 2-PIN PLUG GOING UP TOWARDS THE DRIVER SIDE TAILLIGHT.

CONNECT THE 2-PIN FEMALE PLUG OF THE T-HARNESS INTO THE MALE 2-PIN PLUG OF THE THIRD BRAKE LIGHT HARNESS.

THIRD BRAKE LIGHT HARNESS

T-HARNESS

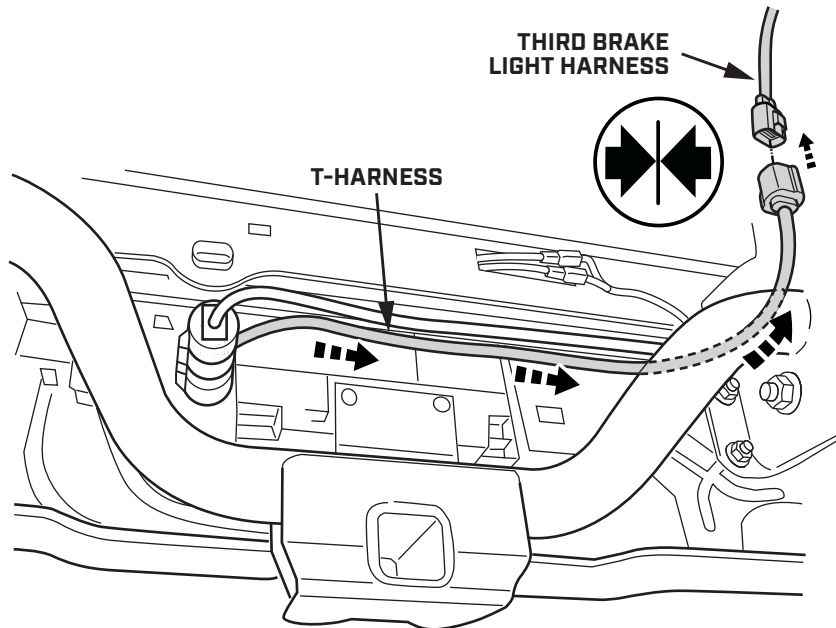

## STEP 70



### TEST YOUR BRAKE LIGHTS & TURN SIGNALS

- ▼ START THE TRUCK. SOME MODELS MAY TAKE UP TO 30 SECONDS FOR THE VEHICLE TO DETECT THE NEW CONNECTION.
- ▼ CHECK THE BRAKE LIGHTS AND TURN SIGNALS TO BE SURE THEY ARE FUNCTIONING PROPERLY.
- ▼ ONCE YOU HAVE CONFIRMED THAT THE LIGHTS ARE WORKING CORRECTLY, SECURE THE HARNESS WITH CABLE TIES.
- ▼ BE SURE NOT TO INTERFERE WITH ANY MOVING PARTS ON THE VEHICLE.
- ▼ YOUR CAP INSTALLATION IS COMPLETE. YOU CAN FIND SMARTCAP CONTACT INFORMATION ON PAGE 39.

# STEP 71

## WITHOUT 7-WAY CONNECTOR

UNTIE THE THIRD BRAKE LIGHT EXTENSION HARNESS FROM WHERE IT IS ATTACHED TO THE SMARTCAP AT THE LEFT REAR CORNER.

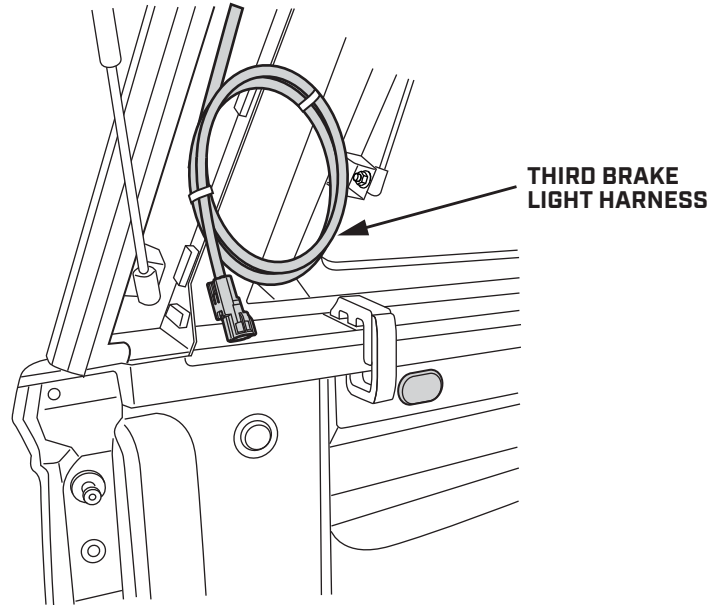

# STEP 72

## WITHOUT 7-WAY CONNECTOR

REMOVE THE GROMMET COVER AT THE TRUCK BED WALL.

ROUTE THE THIRD BRAKE LIGHT HARNESS IN THROUGH THE GROMMET OPENING AND DOWN TOWARDS THE REAR BUMPER.

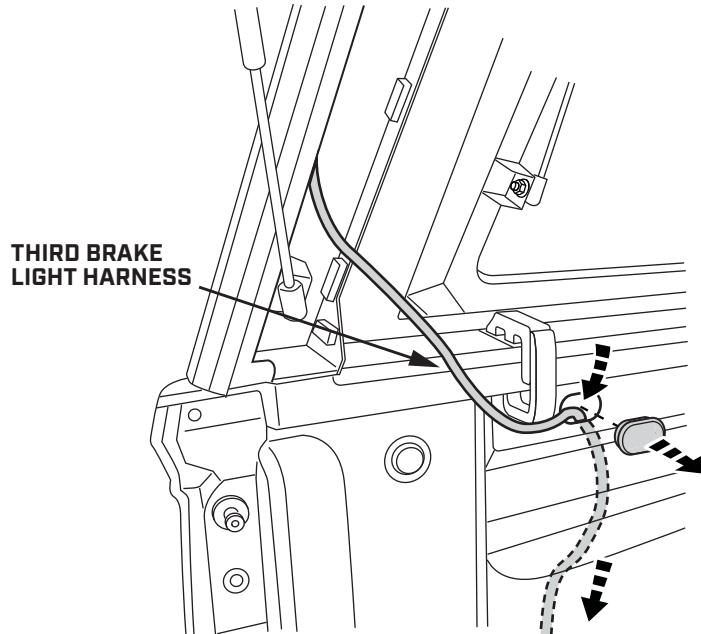

# STEP 73

## WITHOUT 7-WAY CONNECTOR

CONNECT THE T-HARNESS TO THE 2-PIN CONNECTOR AT THE END OF THE BRAKE LIGHT EXTENSION HARNESS.

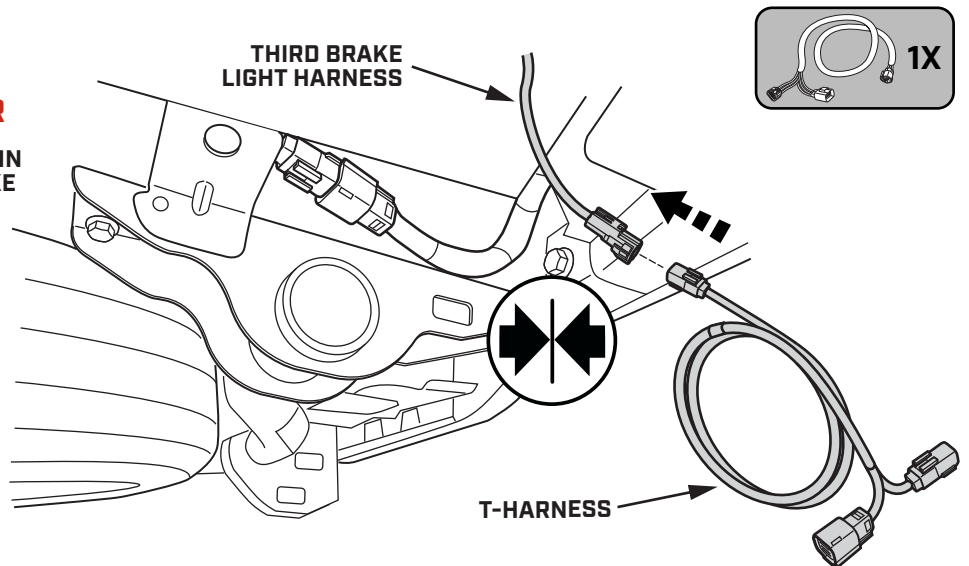

I-SHEET-NA-U3

## STEP 74

### WITHOUT 7-WAY CONNECTOR

LOCATE THE 4-PIN OR 6-PIN CONNECTOR ON THE SIDE OF THE LEFT CHASSIS RAIL AND DISCONNECT IT.

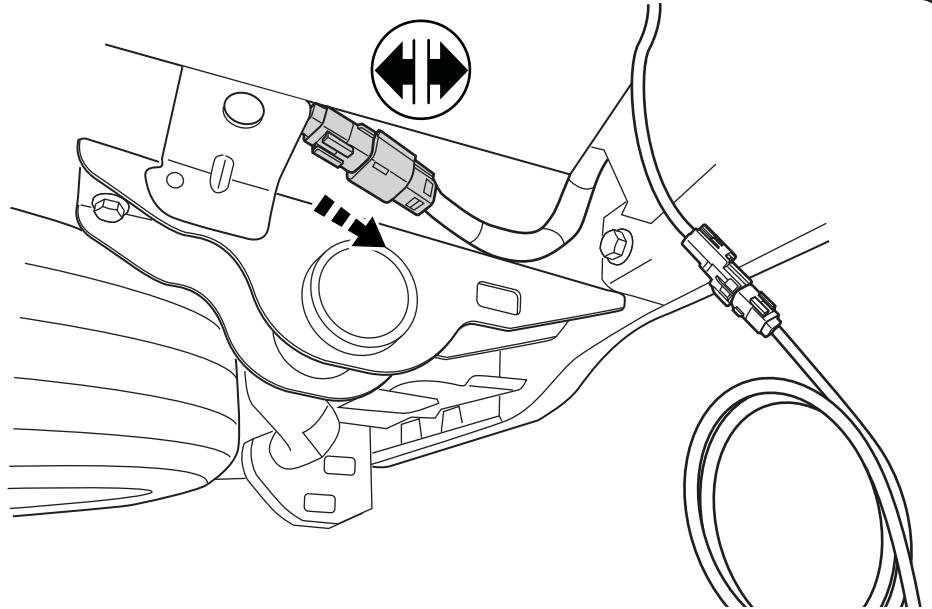

## STEP 75

### WITHOUT 7-WAY CONNECTOR

CONNECT THE T-HARNESS FEMALE CONNECTOR TO THE VEHICLE HARNESS MALE CONNECTOR.

CONNECT THE T-HARNESS MALE CONNECTOR TO THE VEHICLE HARNESS FEMALE CONNECTOR.

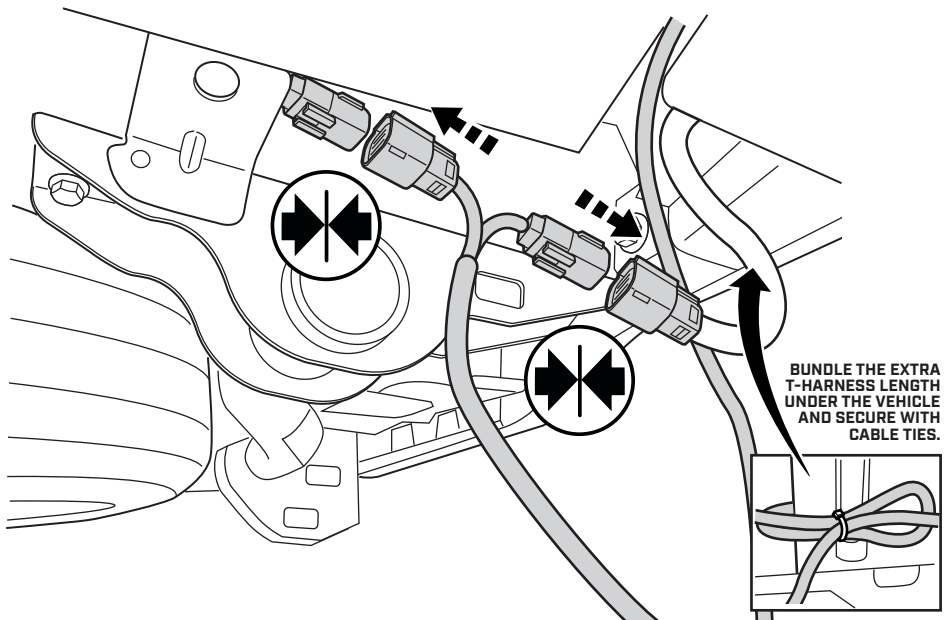

## STEP 76



### TEST YOUR BRAKE LIGHTS & TURN SIGNALS

- ▼ START THE TRUCK. SOME MODELS MAY TAKE UP TO 30 SECONDS FOR THE VEHICLE TO DETECT THE NEW CONNECTION.
- ▼ CHECK THE BRAKE LIGHTS AND TURN SIGNALS TO BE SURE THEY ARE FUNCTIONING PROPERLY.
- ▼ ONCE YOU HAVE CONFIRMED THAT THE LIGHTS ARE WORKING CORRECTLY, SECURE THE HARNESS WITH CABLE TIES.
- ▼ BE SURE NOT TO INTERFERE WITH ANY MOVING PARTS ON THE VEHICLE.
- ▼ YOUR CAP INSTALLATION IS COMPLETE. YOU CAN FIND SMARTCAP CONTACT INFORMATION ON PAGE 39.



# STEP 77

## FORD RANGER

UNTIE THE THIRD BRAKE LIGHT EXTENSION HARNESS FROM WHERE IT IS ATTACHED TO THE SMARTCAP AT THE RIGHT REAR CORNER.

NOTE: THE CONNECTOR ON THE END OF THE HARNESS WILL NEED TO BE DE-PINNED IN ORDER TO ROUTE THROUGH THIS HOLE.

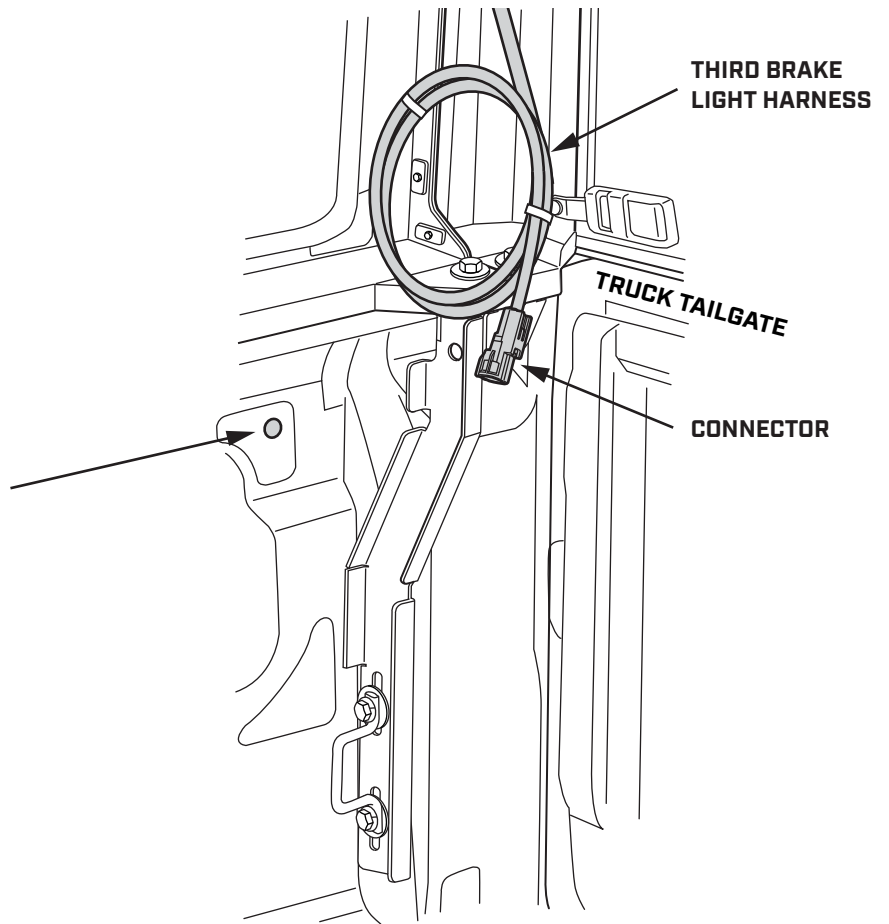

# STEP 78

## FORD RANGER

DE-PIN CONNECTOR.

 TAKE NOTE OF WIRE ORIENTATION

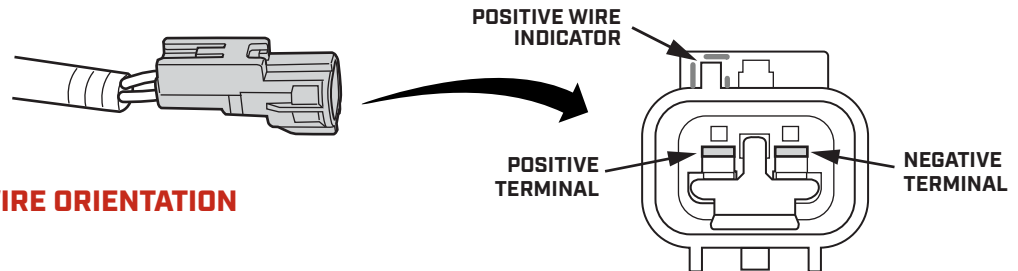

**A** USE A SCEWDRIVER TO PULL THE LOCK CLIP FORWARD.

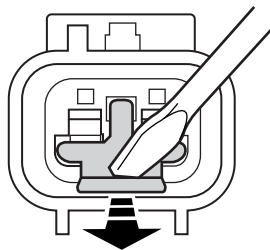

**B** USE A PIN TOOL TO PRESS DOWN ON THE WIRE RELEASE TABS.

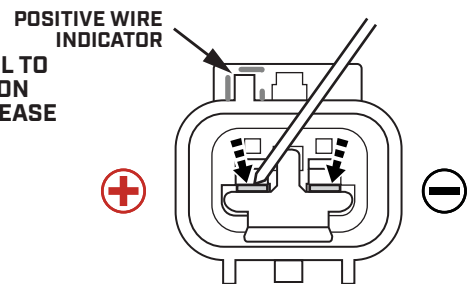

**C** WHILE PRESSING DOWN ON THE RELEASE TABS, REMOVE EACH OF THE WIRES FROM THE CONNECTOR.

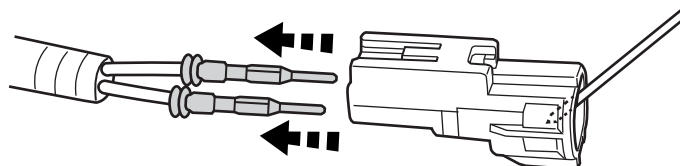

I-SHEET-NA-U3

# STEP 79

## FORD RANGER

ROUTE THE THIRD BRAKE LIGHT EXTENSION HARNESS THROUGH THE HOLE AND DOWN TOWARDS THE INSIDE REAR BUMPER.



**BE SURE NOT TO DAMAGE TERMINALS**

THIRD BRAKE LIGHT HARNESS

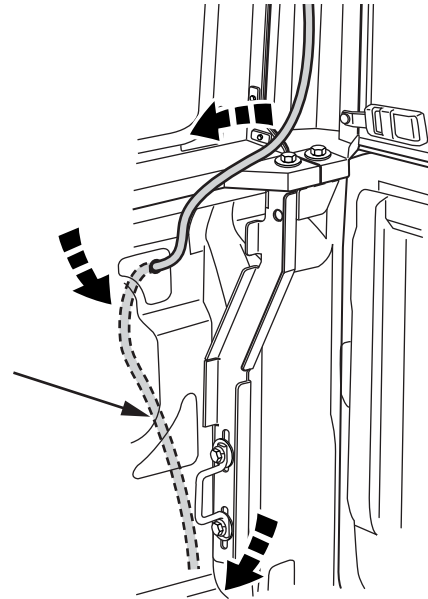

# STEP 80

## FORD RANGER

RE-ATTACH THE CONNECTOR TO THE THIRD BRAKE LIGHT HARNESS IN THE SAME FASHION AS IT WAS REMOVED.

SEE STEP 75

POSITIVE WIRE INDICATOR

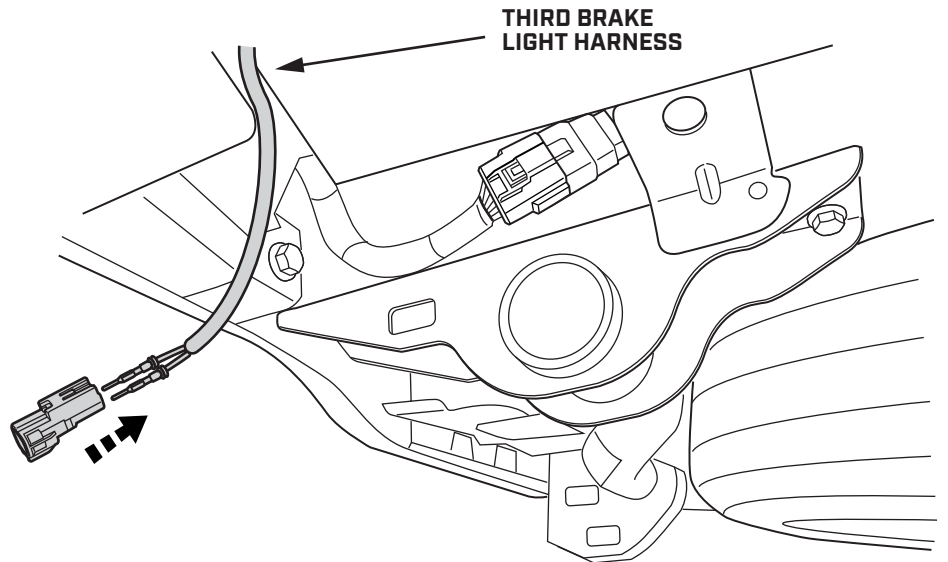
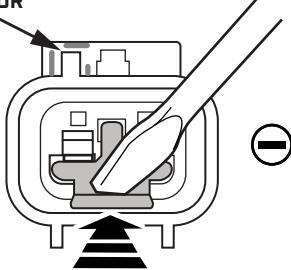

# STEP 81

## FORD RANGER WITH LED TAILLIGHTS

CONNECT THE LED T-HARNESS TO THE 2-PIN CONNECTOR AT THE END OF THE BRAKE LIGHT EXTENSION HARNESS.

LED T-HARNESS

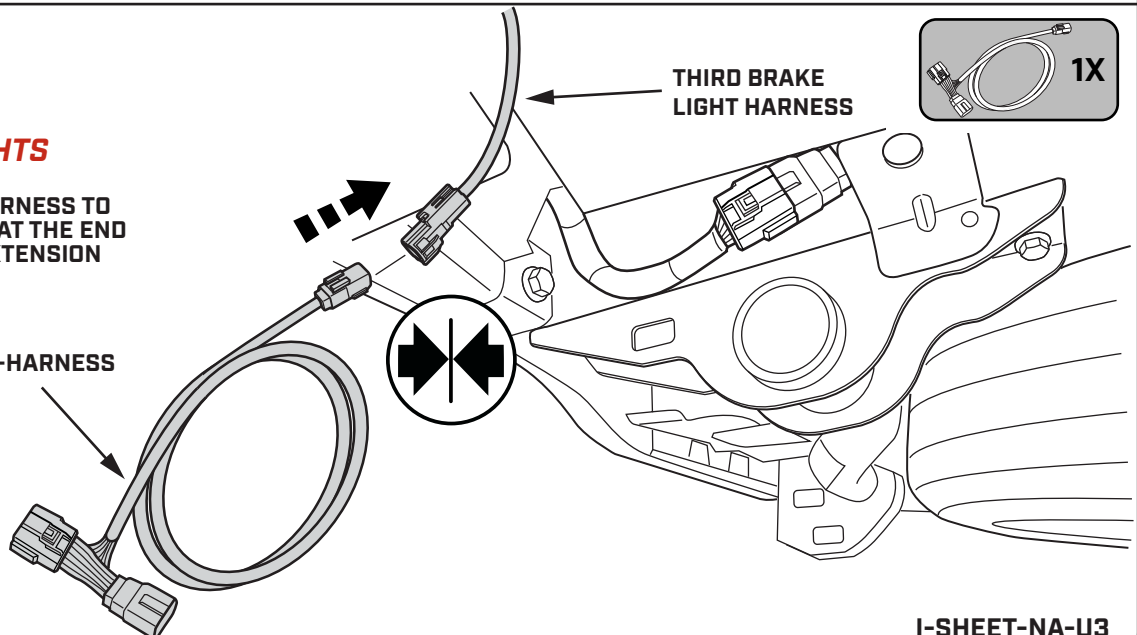

I-SHEET-NA-U3

## STEP 82

### FORD RANGER WITH LED TAILLIGHTS

LOCATE THE 16-PIN CONNECTOR ON THE SIDE OF THE PASSENGER CHASSIS RAIL AND DISCONNECT IT.

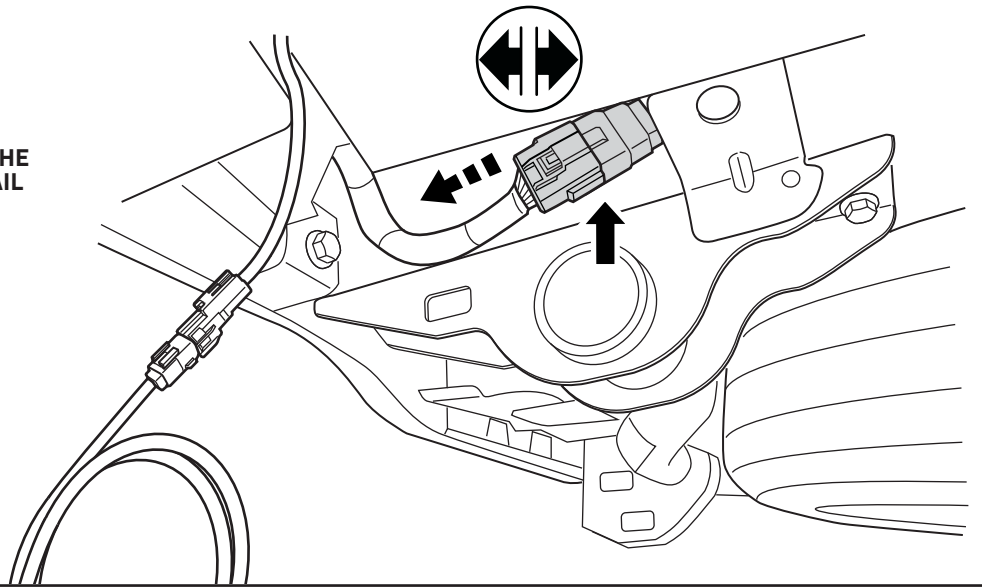

## STEP 83

### FORD RANGER WITH LED TAILLIGHTS

CONNECT THE T-HARNESS FEMALE CONNECTOR TO THE VEHICLE HARNESS MALE CONNECTOR.

CONNECT THE T-HARNESS MALE CONNECTOR TO THE VEHICLE HARNESS FEMALE CONNECTOR.

BUNDLE THE EXTRA T-HARNESS LENGTH UNDER THE VEHICLE AND SECURE WITH CABLE TIES

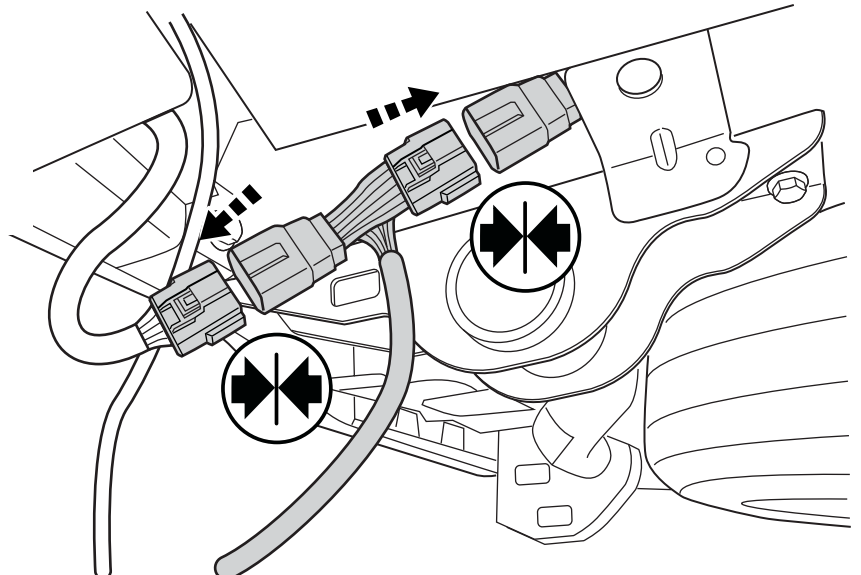
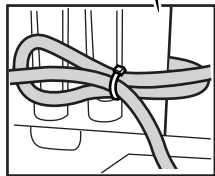

## STEP 84

### FORD RANGER INCANDESCENT TAILLIGHTS

CONNECT THE INCANDESCENT T-HARNESS TO THE 2-PIN CONNECTOR AT THE END OF THE BRAKE LIGHT EXTENSION HARNESS.

INCANDESCENT T-HARNESS

THIRD BRAKE LIGHT HARNESS

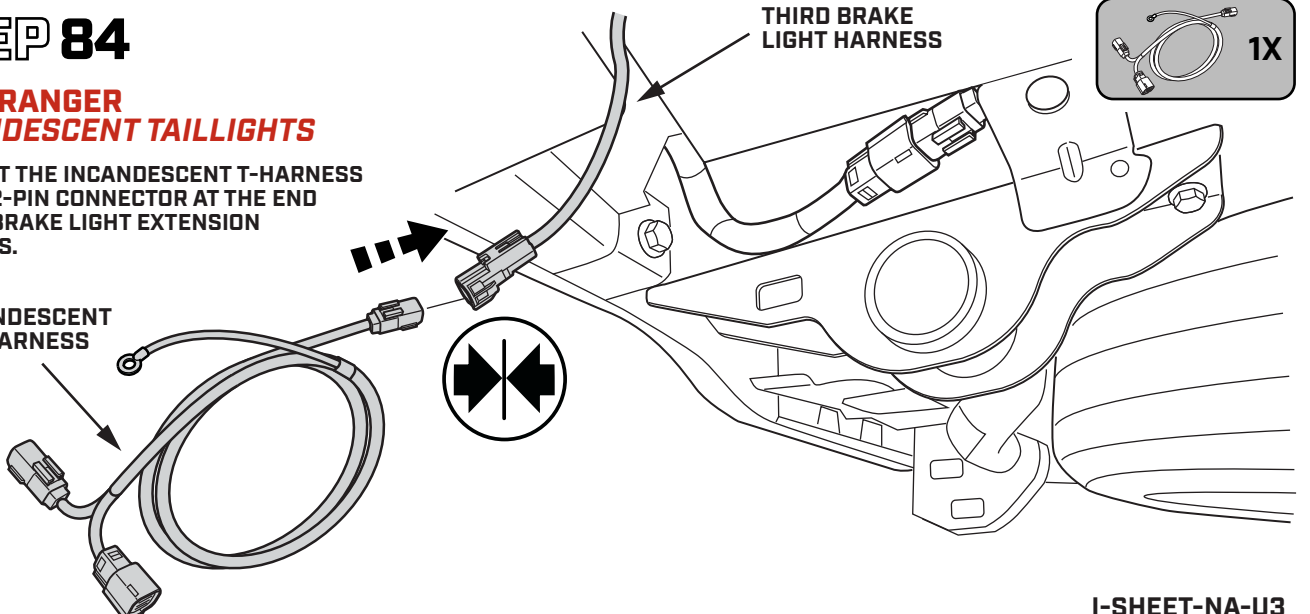
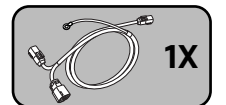

I-SHEET-NA-U3

## STEP 85

### FORD RANGER INCANDESCENT TAILLIGHTS

LOCATE THE 6-PIN CONNECTOR ON THE SIDE OF THE PASSENGER CHASSIS RAIL AND DISCONNECT IT.

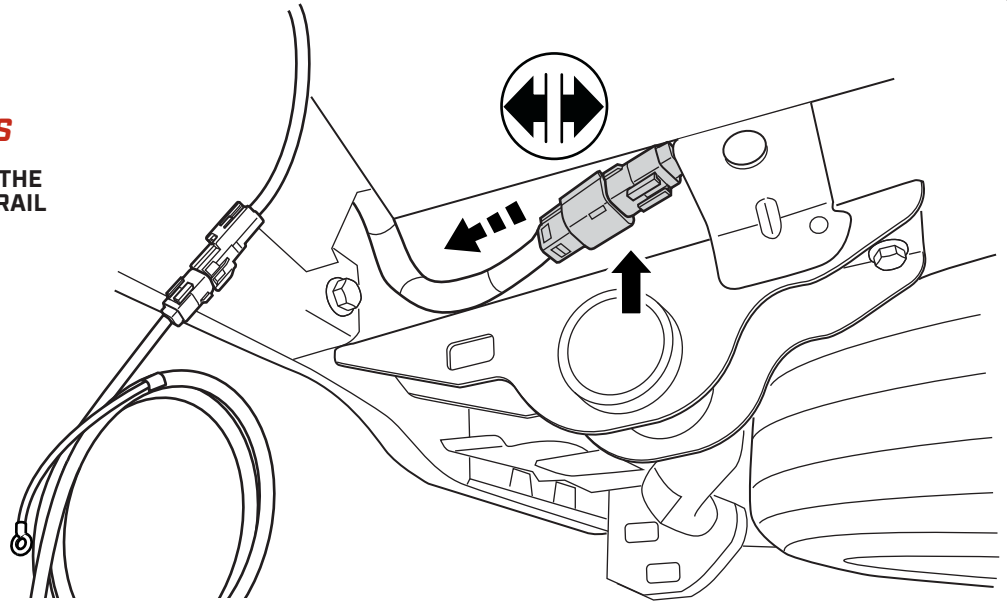

## STEP 86

### FORD RANGER INCANDESCENT TAILLIGHTS

CONNECT THE T-HARNESS FEMALE CONNECTOR TO THE VEHICLE HARNESS MALE CONNECTOR.

CONNECT THE T-HARNESS MALE CONNECTOR TO THE VEHICLE HARNESS FEMALE CONNECTOR.

BUNDLE THE EXTRA T-HARNESS LENGTH UNDER THE VEHICLE AND SECURE WITH CABLE TIES

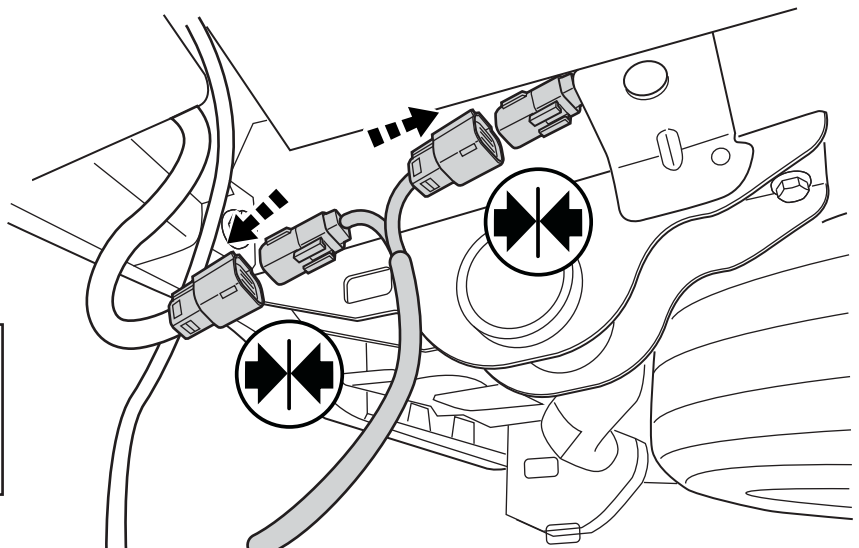
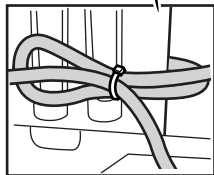

## STEP 87

### FORD RANGER INCANDESCENT TAILLIGHTS

SECURE THE GROUND WIRE ON THE T-HARNESS TO THE CHASSIS AT A SUITABLE LOCATION UNDER THE VEHICLE.

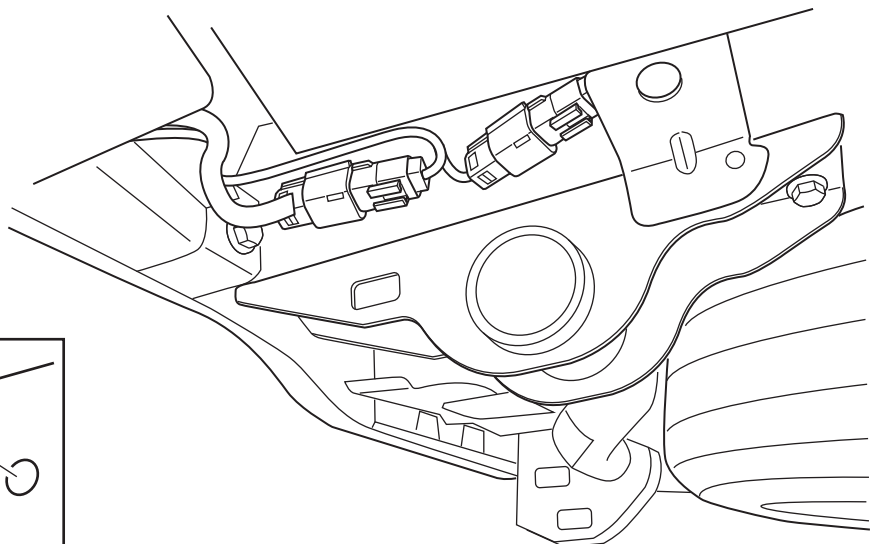
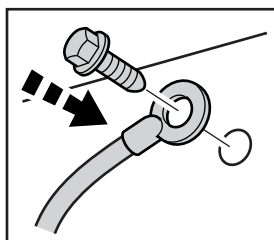

I-SHEET-NA-U3

## STEP 88



### TEST YOUR BRAKE LIGHTS & TURN SIGNALS

- ▼ START THE TRUCK. SOME MODELS MAY TAKE UP TO 30 SECONDS FOR THE VEHICLE TO DETECT THE NEW CONNECTION.
- ▼ CHECK THE BRAKE LIGHTS AND TURN SIGNALS TO BE SURE THEY ARE FUNCTIONING PROPERLY.
- ▼ ONCE YOU HAVE CONFIRMED THAT THE LIGHTS ARE WORKING CORRECTLY, SECURE THE HARNESS WITH CABLE TIES.
- ▼ BE SURE NOT TO INTERFERE WITH ANY MOVING PARTS ON THE VEHICLE.



THANKS FOR YOUR PURCHASE.  
PLEASE LET US KNOW IF YOU HAVE ANY QUESTIONS.

**SMARTCAP.COM**

SUPPORT.NA@SMARTCAP.COM - NORTH AMERICA

SUPPORT.SA@SMARTCAP.COM - REST OF WORLD

