

**SMARTCAP®**

## **INSTRUCTION GUIDE EVO, EVOa & EVOc SERIES**

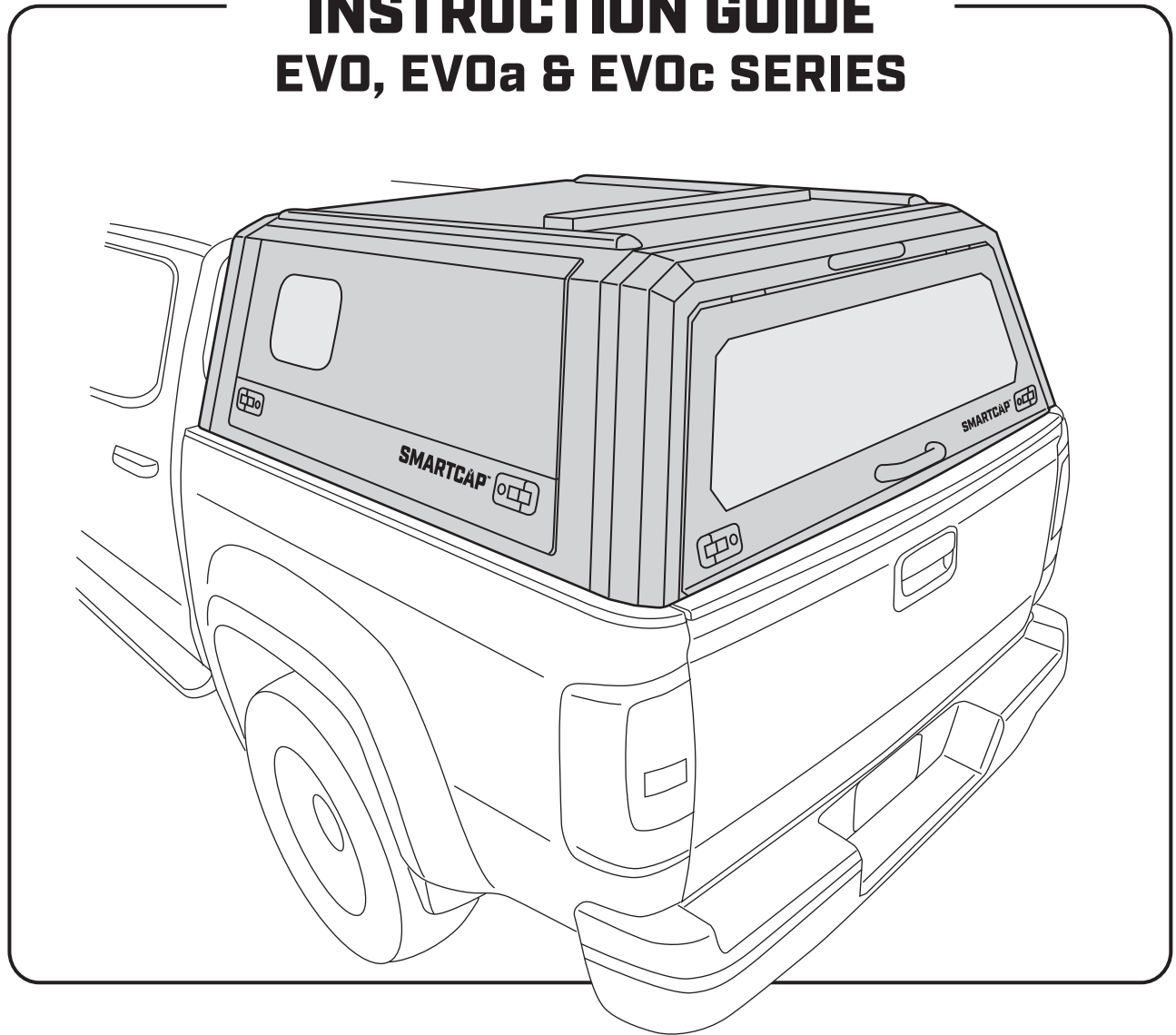

- ▼ **PREPARE A CLEAN WORK AREA.**
- ▼ **WE RECOMMEND A MINIMUM OF 2 PEOPLE FOR ASSEMBLY.**
- ▼ **ENSURE THE REQUIRED TOOLS ARE PRESENT AND ALL HARDWARE CONTENTS ARE ACCOUNTED FOR.**
- ▼ **NEVER USE ACETONE OR THINNERS ON PAINTED PARTS.**
- ▼ **READ THROUGH THE ENTIRE INSTRUCTION GUIDE BEFORE STARTING THIS PROCEDURE AND FOLLOW THE STEPS CAREFULLY TO AVOID ANY DAMAGE TO THE COMPONENTS OR THE VEHICLE.**

**SMARTCAP.COM - SUPPORT.NA@SMARTCAP.COM - NORTH AMERICA**



**I-SHEET-NA-U2**

## TOOLS REQUIRED

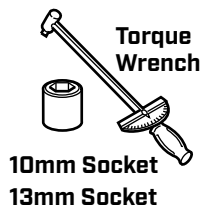
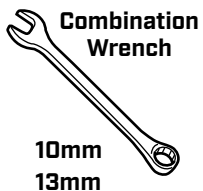
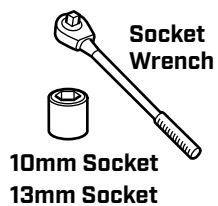

## IMPORTANT

- ▼ USE ONLY THE TOOLS RECOMMENDED ABOVE.
- ▼ USE ONLY THE HARDWARE PROVIDED IN THIS KIT.
- ▼ ASSISTANCE WILL BE NEEDED FOR THIS INSTALLATION.  
FOUR PEOPLE ARE RECOMMENDED TO LIFT THE SMARTCAP ONTO THE VEHICLE.
- ▼ AVOID PINCHING OR CRUSHING HANDS AND FINGERS.
- ▼ INSPECT ALL KIT COMPONENTS FOR DAMAGE BEFORE ASSEMBLY.
- ▼ NEVER USE ACETONE OR THINNERS ON PAINTED PARTS.

## COMPONENTS

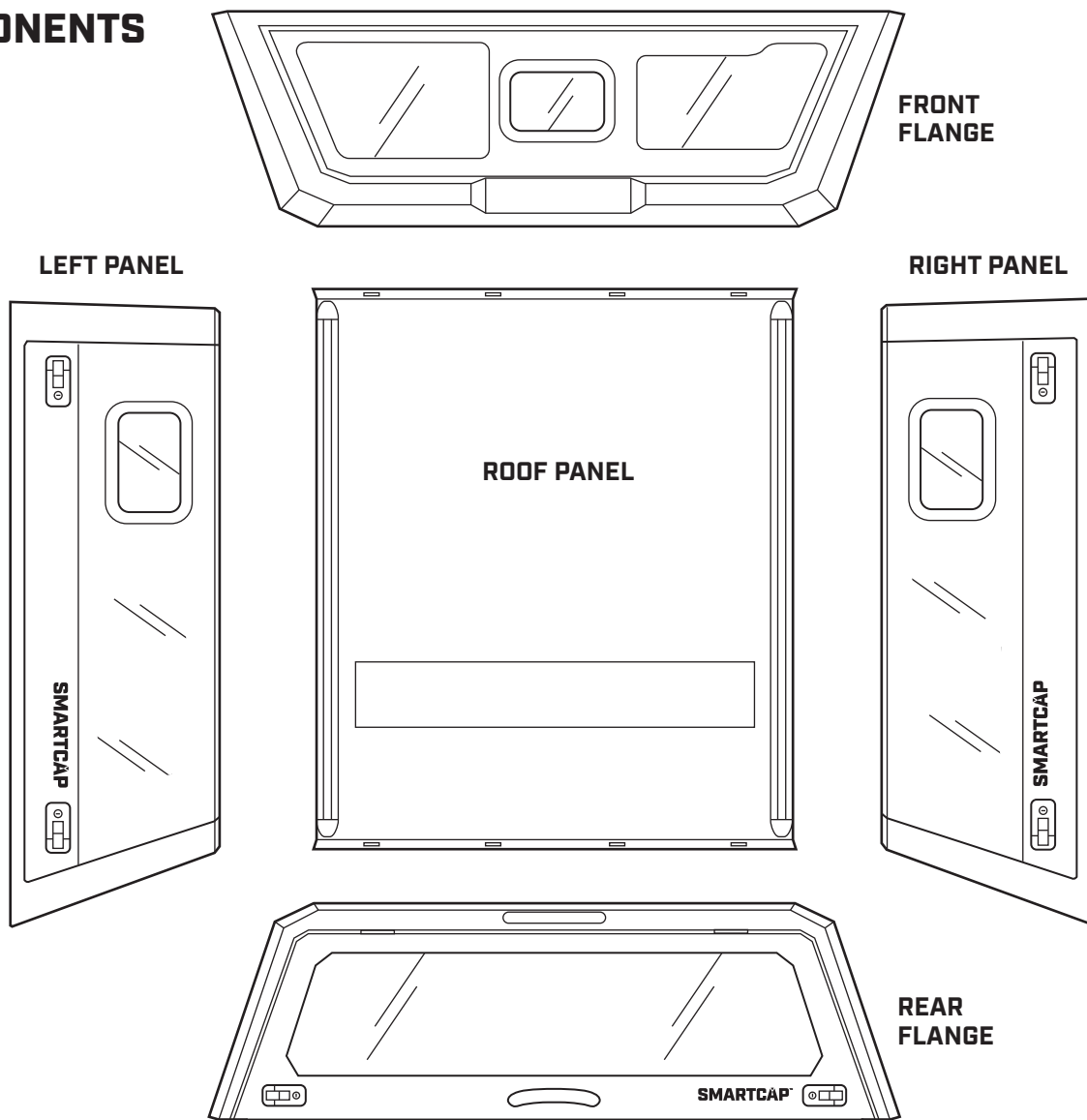

I-SHEET-NA-U2

# ASSEMBLY HARDWARE



## IMPORTANT

▼ DETERMINE WHICH VERSION YOUR FITMENT KIT CONTAINS. (VERSION A OR VERSION B)

### [PRE-FASTENED TO FLANGES]

#### VERSION A



M6  
BOLT  
28X

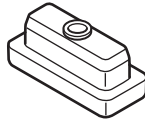

FASTENER  
BLOCK  
28X

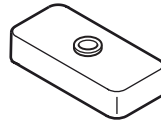

FASTENER BLOCK  
CLAMP  
28X



M6 LOCK  
WASHER  
28X

#### VERSION B



M6  
BOLT  
28X

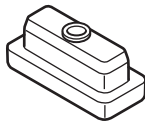

FASTENER  
BLOCK  
28X

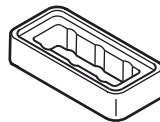

FASTENER BLOCK  
CLAMP  
28X



M6 LOCK  
WASHER  
28X



FASTENER BLOCK  
LOADSPREADER  
28X

### D-RUBBERER 1X

#### VERSION A

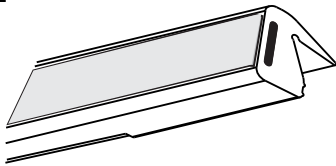

#### VERSION B

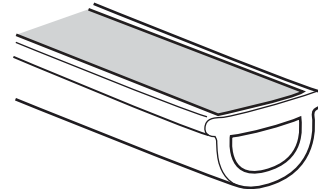

### SPARE HARDWARE 1X

#### VERSION A

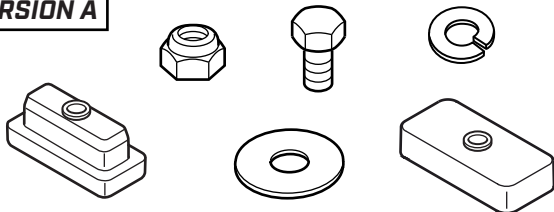

#### VERSION B

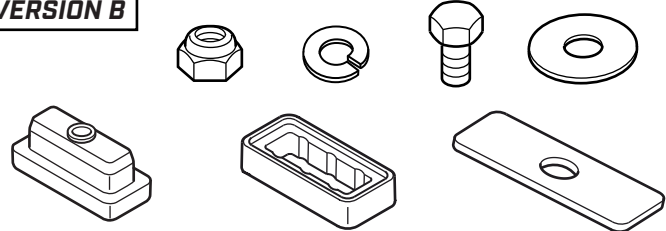

### [PRE-FASTENED TO ROOF PANEL]



M6  
LOCK  
NUT

10X SHORT BED

12X STANDARD BED



M6  
FENDER  
WASHER

10X SHORT BED

12X STANDARD BED

# STEP 1



**IMPORTANT**



▼ BE SURE TO REMOVE ALL FIVE PANELS FROM THEIR PACKAGING AND INSPECT THE PAINTED SURFACES PRIOR TO ASSEMBLY, AS SMARTCAP WILL NOT ACCEPT PAINT DAMAGE WARRANTY CLAIMS AFTER ASSEMBLY IS COMPLETED. IF MANUFACTURING IMPERFECTIONS OR SHIPPING DAMAGES ARE FOUND, DO NOT CONTINUE WITH THE ASSEMBLY PROCESS AND CONTACT [SUPPORT.NA@SMARTCAP.COM](mailto:SUPPORT.NA@SMARTCAP.COM).

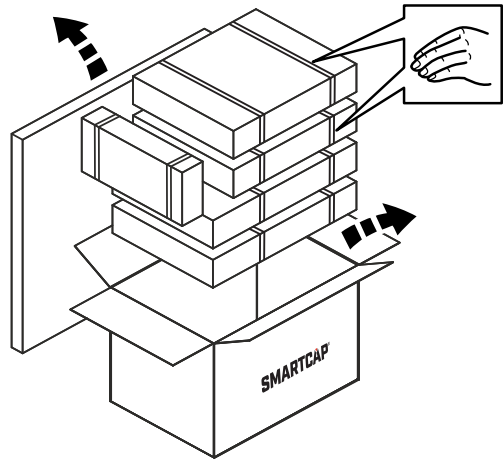

# STEP 2

PLACE THE ROOF PANEL WHERE YOU PLAN TO ASSEMBLE THE CAP AND USE THE LID AS A WORK SURFACE.

**STICKER SIDE UP**

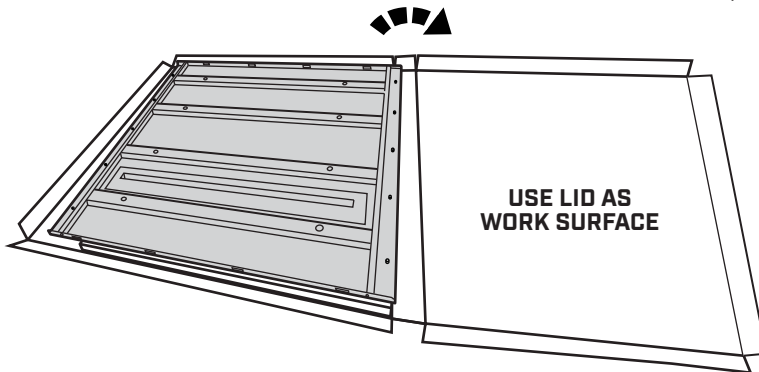
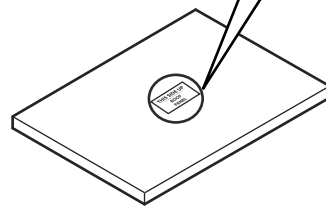

# STEP 3

USE A 10MM COMBINATION WRENCH TO REMOVE ALL HARDWARE FROM THE ROOF PANEL AND SAVE FOR REUSE.



**AIR VENT INDICATES REAR**

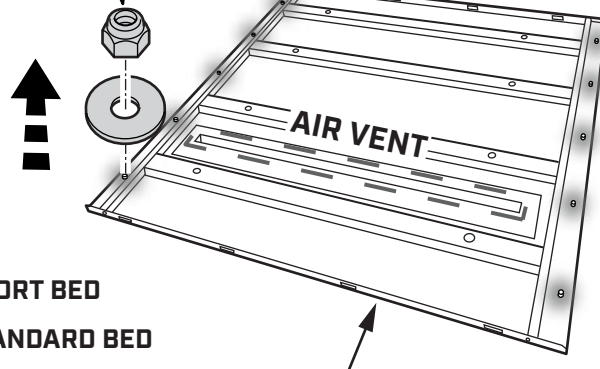
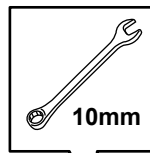

**10X** SHORT BED

**12X** STANDARD BED

**ROOF PANEL**

**I-SHEET-NA-U2**

## STEP 4

LOCATE THE RIGHT PANEL IN THE SMARTCAP PACKAGE AND BRING IT TO YOUR WORK AREA.

2 PERSON JOB



**THE SLANTED EDGE INDICATES REAR**

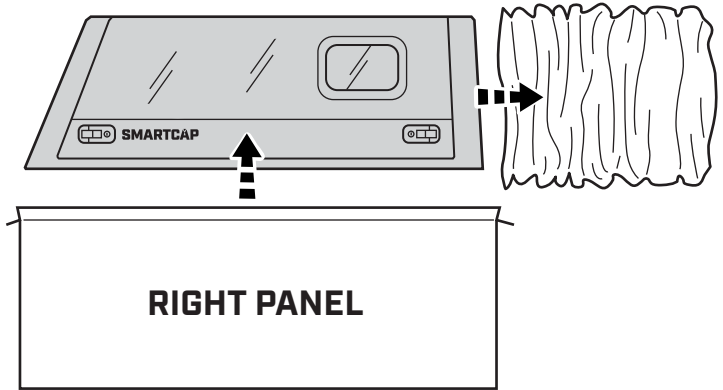
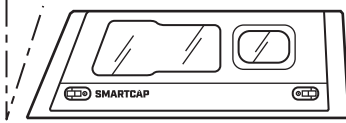

## STEP 5

INSERT PANEL TABS INTO NARROW SLOTS JUST ABOVE FOAM PADDING ON ROOF PANEL.

TAP FIRMLY WITH PALM OF HAND UNTIL THERE IS A 2-3MM GAP.

2 PERSON JOB



SLANTED EDGE TOWARDS REAR

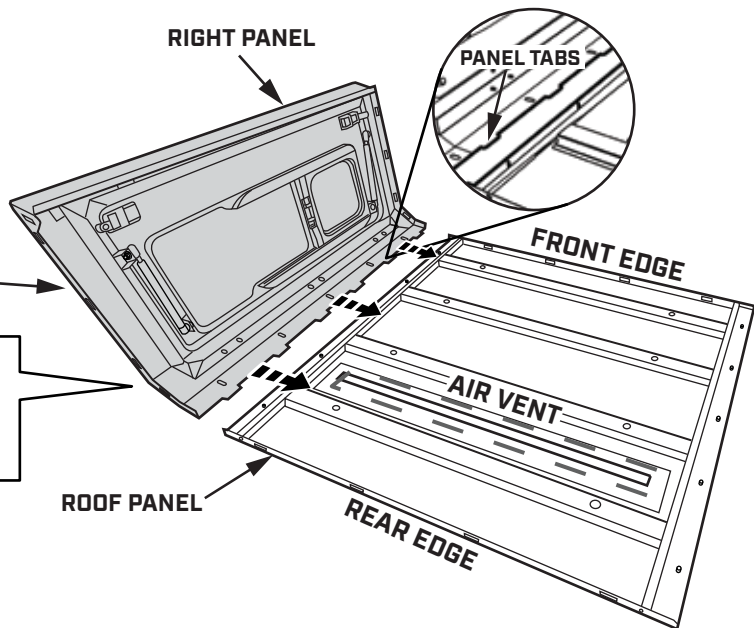
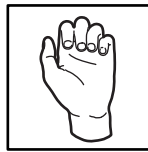

## STEP 6

HAND TIGHTEN M6 LOCK NUT WITH M6 FENDER WASHER TO ALL BOLTS.

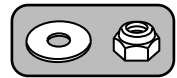

M6 LOCK NUT

M6 FENDER WASHER

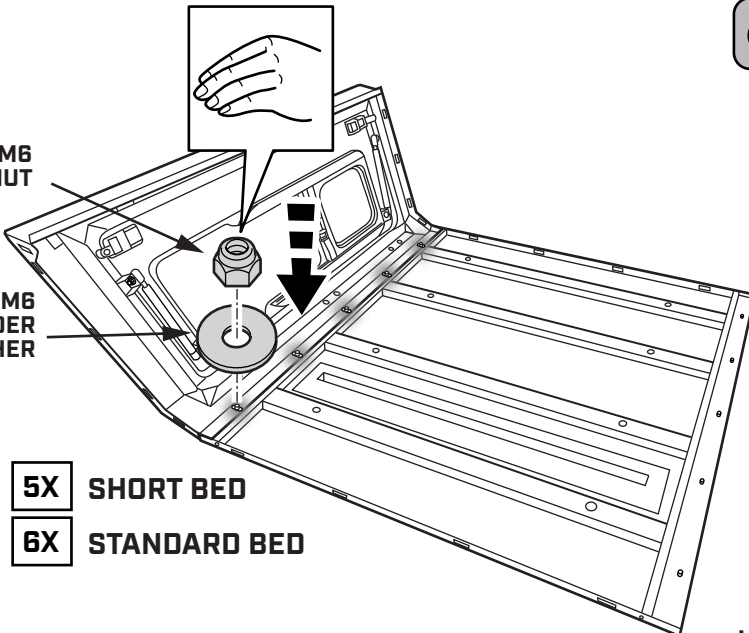

5X SHORT BED

6X STANDARD BED

I-SHEET-NA-U2

# STEP 7

LOCATE THE LEFT PANEL IN THE SMARTCAP PACKAGE AND BRING IT TO YOUR WORK AREA.

2 PERSON JOB

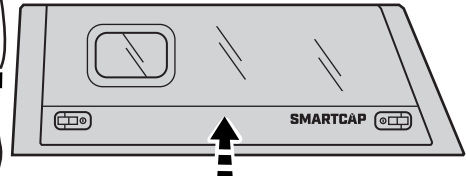
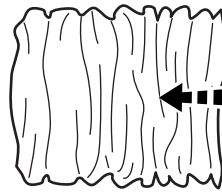

**THE SLANTED EDGE INDICATES REAR**

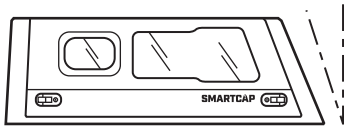

LEFT PANEL

# STEP 8

INSERT PANEL TABS INTO NARROW SLOTS JUST ABOVE FOAM PADDING ON ROOF PANEL.

TAP FIRMLY WITH PALM OF HAND UNTIL THERE IS A 2-3MM GAP.

2 PERSON JOB

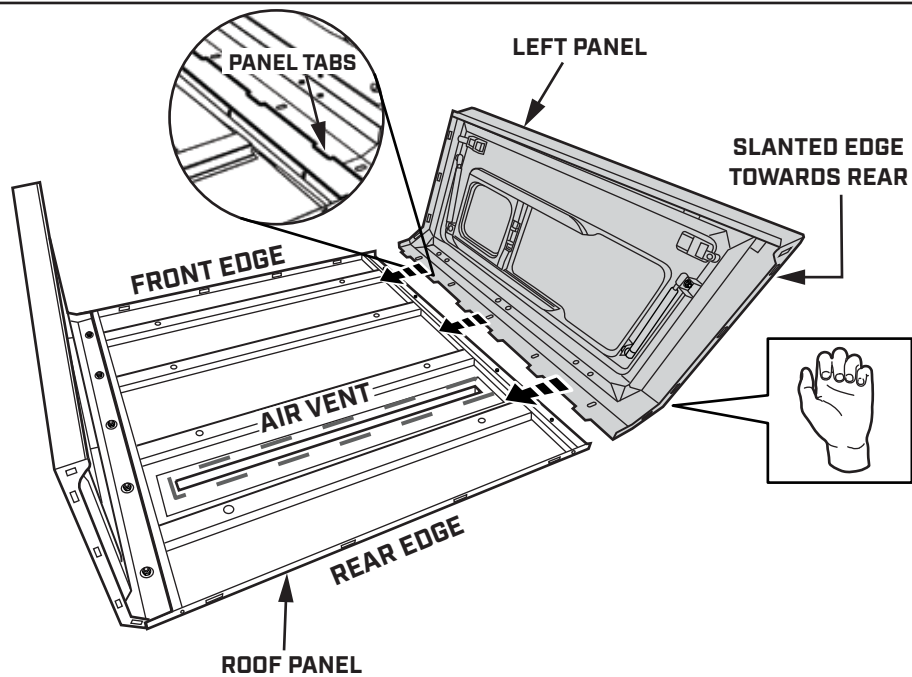

# STEP 9

HAND TIGHTEN M6 LOCK NUT WITH M6 FENDER WASHER TO ALL BOLTS.

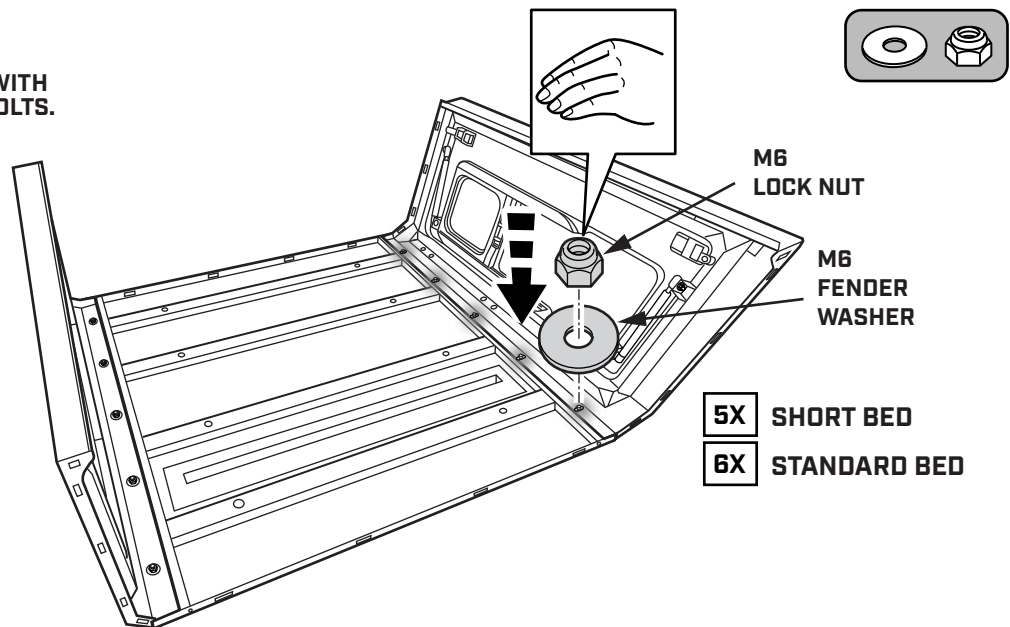

I-SHEET-NA-U2

# STEP 10

PUSH THE SMARTCAP TO EXPOSE A FEW INCHES OF STYRAFOAM UNDERNEATH THE ROOF PANEL TO PROVIDE SUPPORT FOR THE FRONT FLANGE.

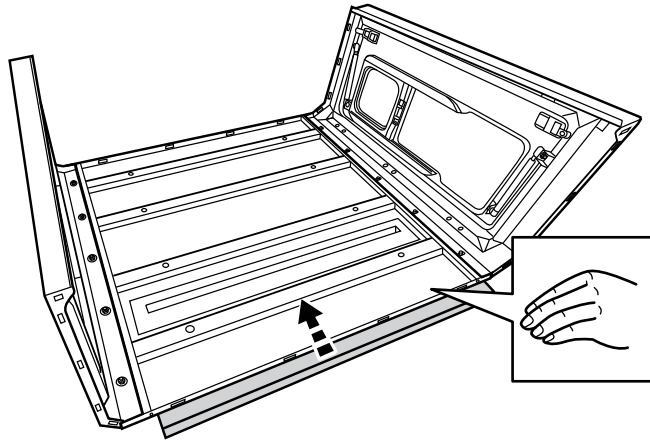

# STEP 11

LOCATE THE FRONT FLANGE IN THE SMARTCAP PACKAGE AND BRING IT TO YOUR WORK AREA.

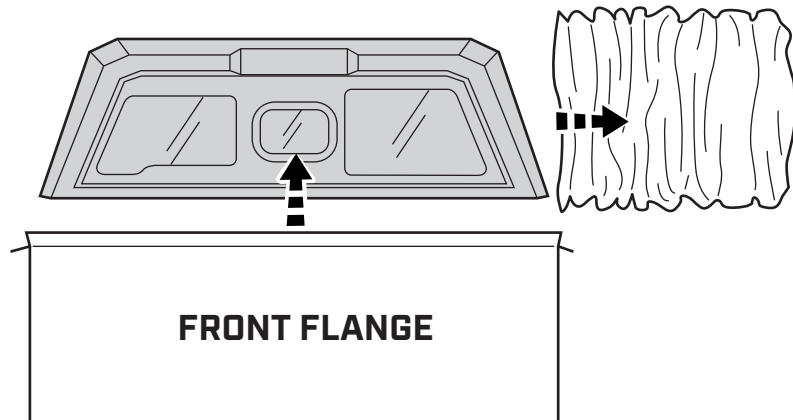

# STEP 12

USE A 10MM COMBINATION WRENCH TO REMOVE ALL HARDWARE FROM THE FRONT FLANGE AND SAVE FOR REUSE



REFER TO PG. 3 TO DETERMINE IF YOU HAVE VERSION A OR B

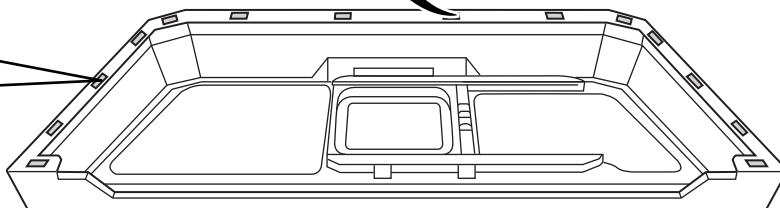
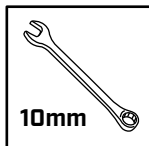
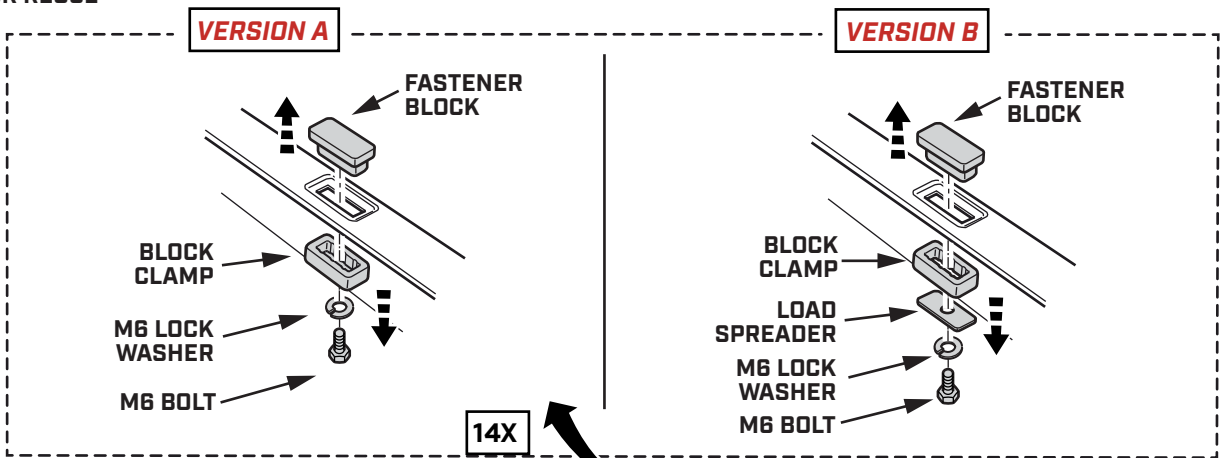

# STEP 13

PLACE FRONT FLANGE AS SHOWN.

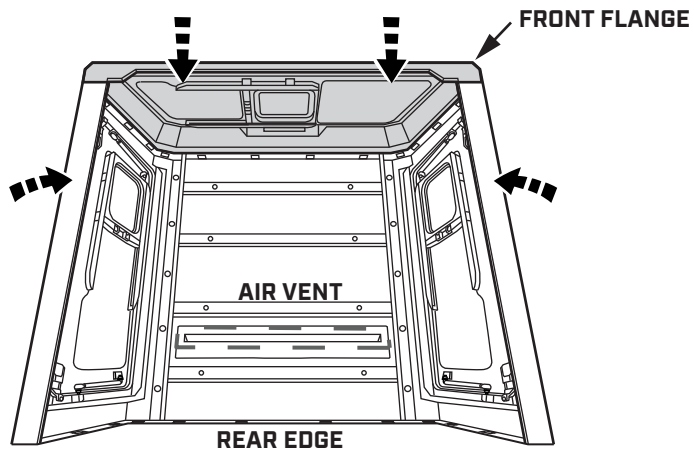

# STEP 14

INSTALL HARDWARE ALONG FRONT FLANGE WITH M6 BOLT ON INSIDE.

START WITH ASSEMBLING FASTENER BLOCKS 1-5.

ADJUST LEFT AND RIGHT PANELS TO ALIGN FASTENER BLOCKS 6-15 FOR ASSEMBLY.

HAND TIGHTEN IN THE SEQUENCE SHOWN.



**REFER TO PG. 3 TO DETERMINE IF YOU HAVE VERSION A OR B**

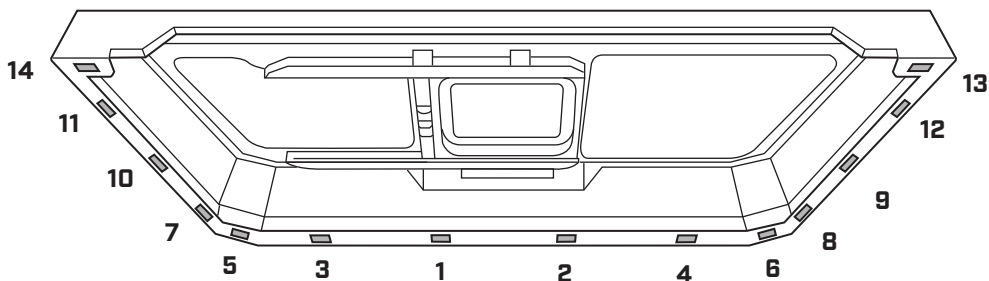
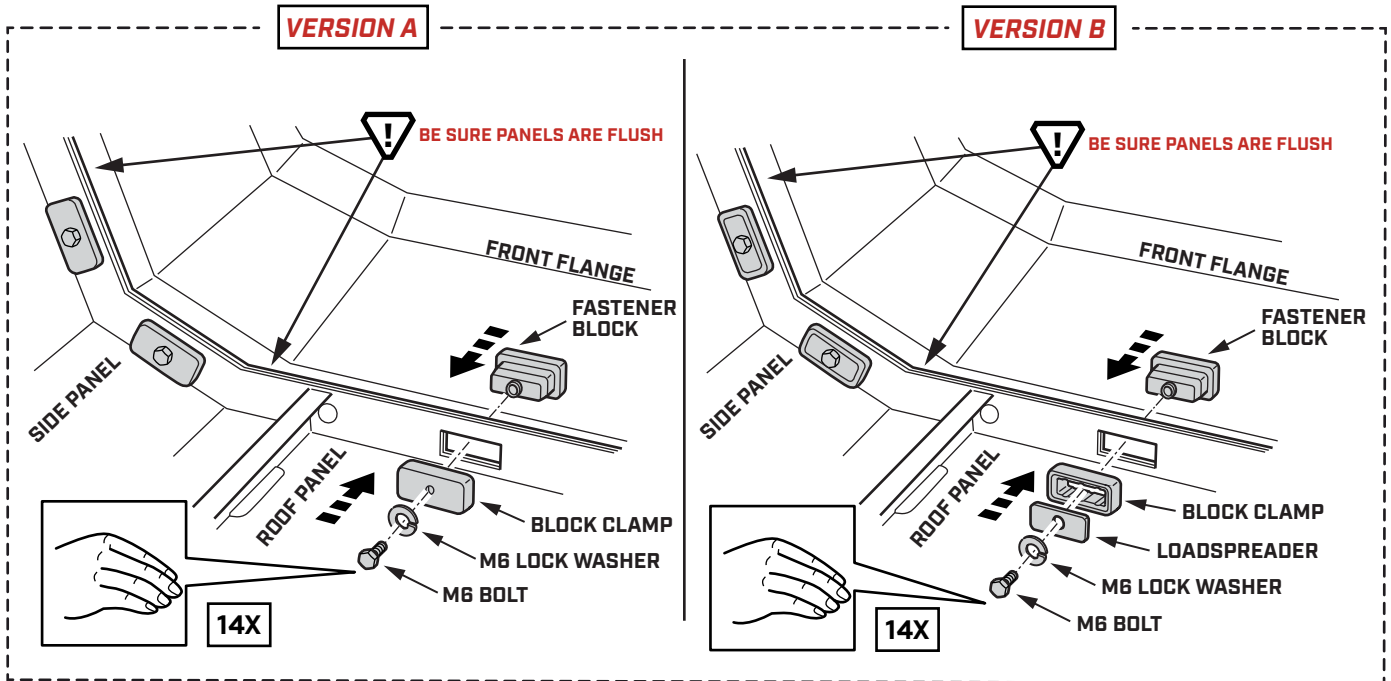

FOLLOW THE TIGHTENING SEQUENCE 1-14

I-SHEET-NA-U2



# STEP 15

PUSH THE SMARTCAP TO EXPOSE A FEW INCHES OF STYRAFOAM UNDERNEATH THE ROOF PANEL TO PROVIDE SUPPORT FOR THE REAR FLANGE.

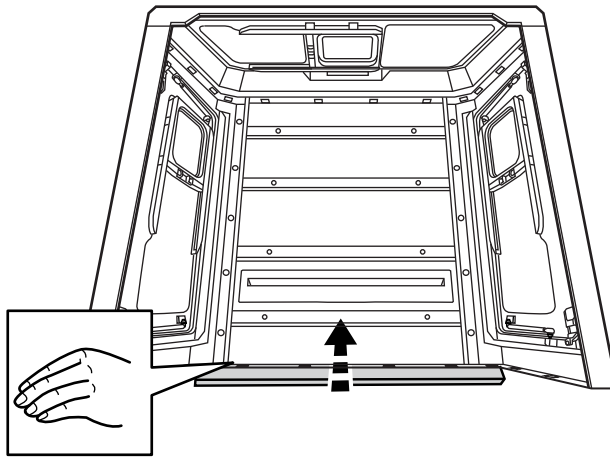

# STEP 16

LOCATE THE REAR FLANGE IN THE SMARTCAP PACKAGE AND BRING IT TO YOUR WORK AREA.

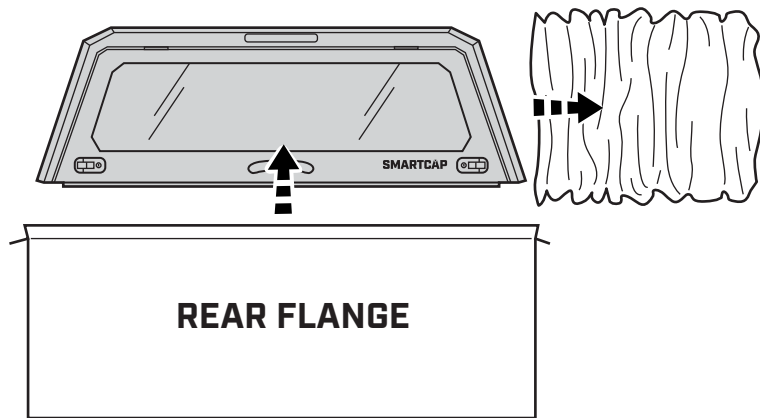

# STEP 17

USE A 10MM COMBINATION WRENCH TO REMOVE ALL HARDWARE FROM THE FRONT FLANGE AND SAVE FOR REUSE.



**REFER TO PG. 3 TO DETERMINE IF YOU HAVE VERSION A OR B**

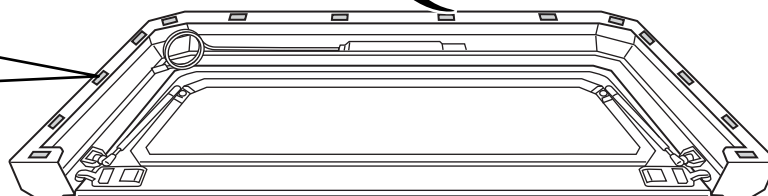
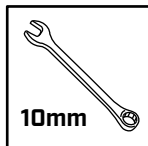
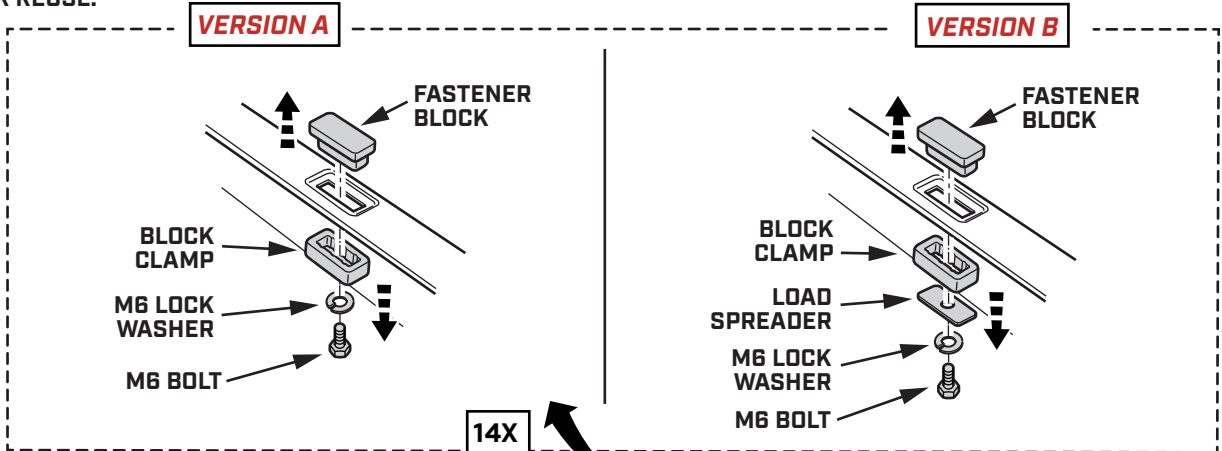

# STEP 18

PLACE REAR FLANGE AS SHOWN.

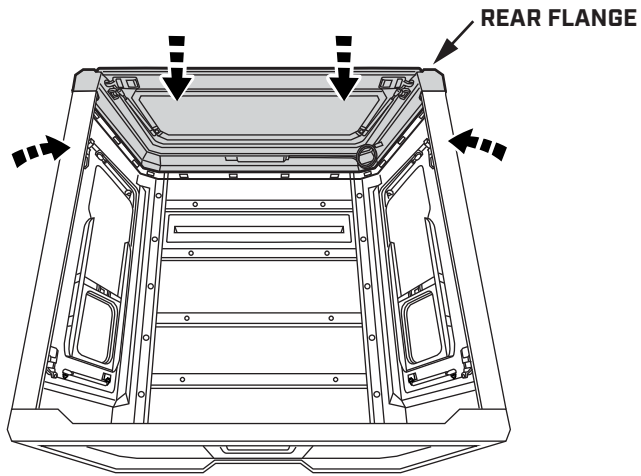
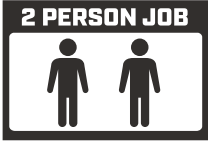

# STEP 19

INSTALL HARDWARE ALONG FRONT FLANGE WITH M6 BOLT ON INSIDE.

START WITH ASSEMBLING FASTENER BLOCKS 1-5.

ADJUST LEFT AND RIGHT PANELS TO ALIGN FASTENER BLOCKS 6-15 FOR ASSEMBLY.

HAND TIGHTEN IN THE SEQUENCE SHOWN.



**REFER TO PG. 3 TO DETERMINE IF YOU HAVE VERSION A OR B**

**VERSION A**

**VERSION B**

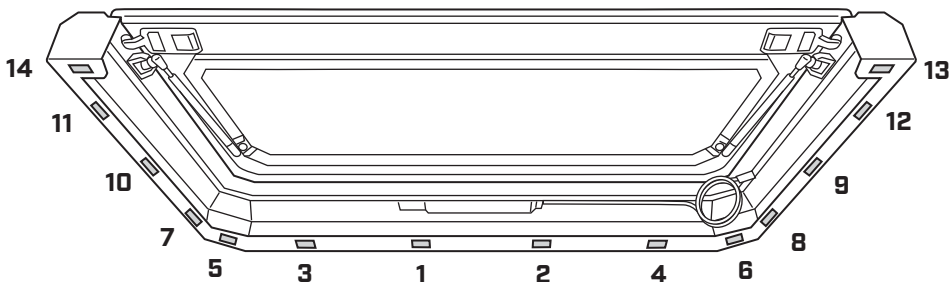
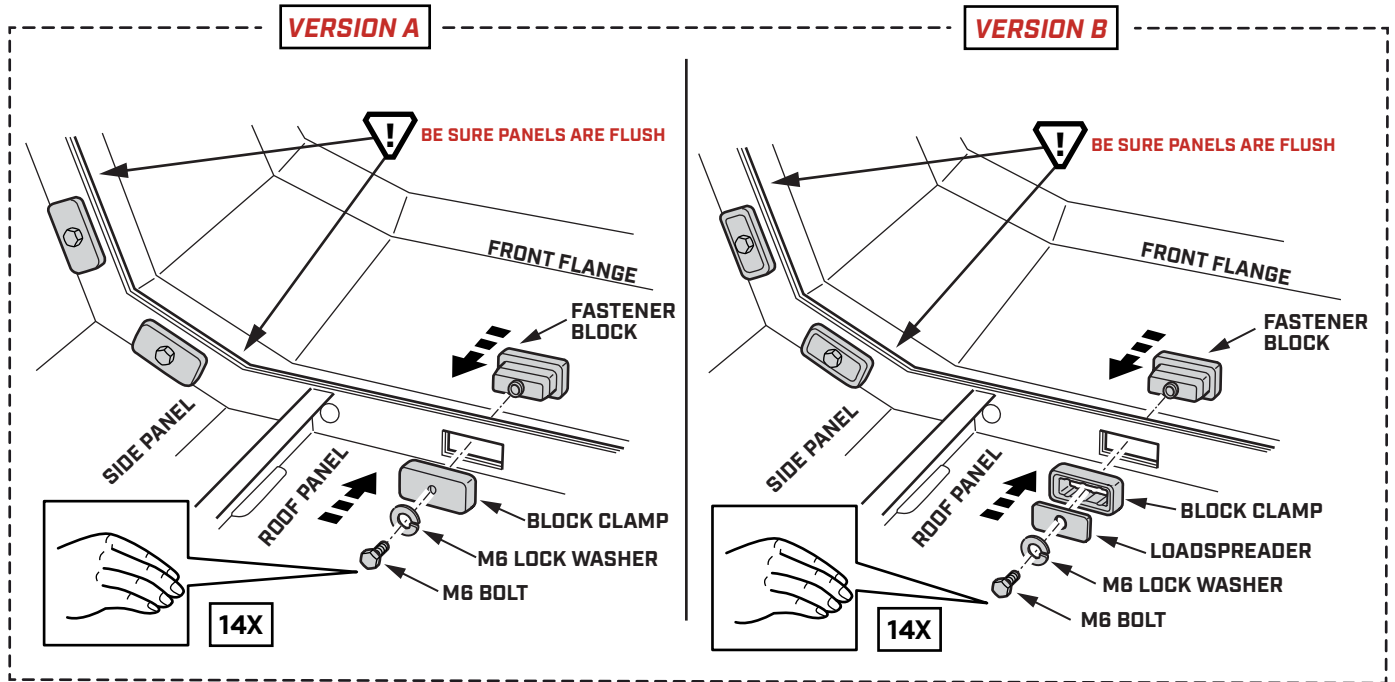

FOLLOW THE TIGHTENING SEQUENCE 1-14

I-SHEET-NA-U2

# STEP 20

TIGHTEN ALL HARDWARE WITH TORQUE WRENCH AND 10MM SOCKET TO 3.7 FT. LBS. [5 NEWTON METERS]

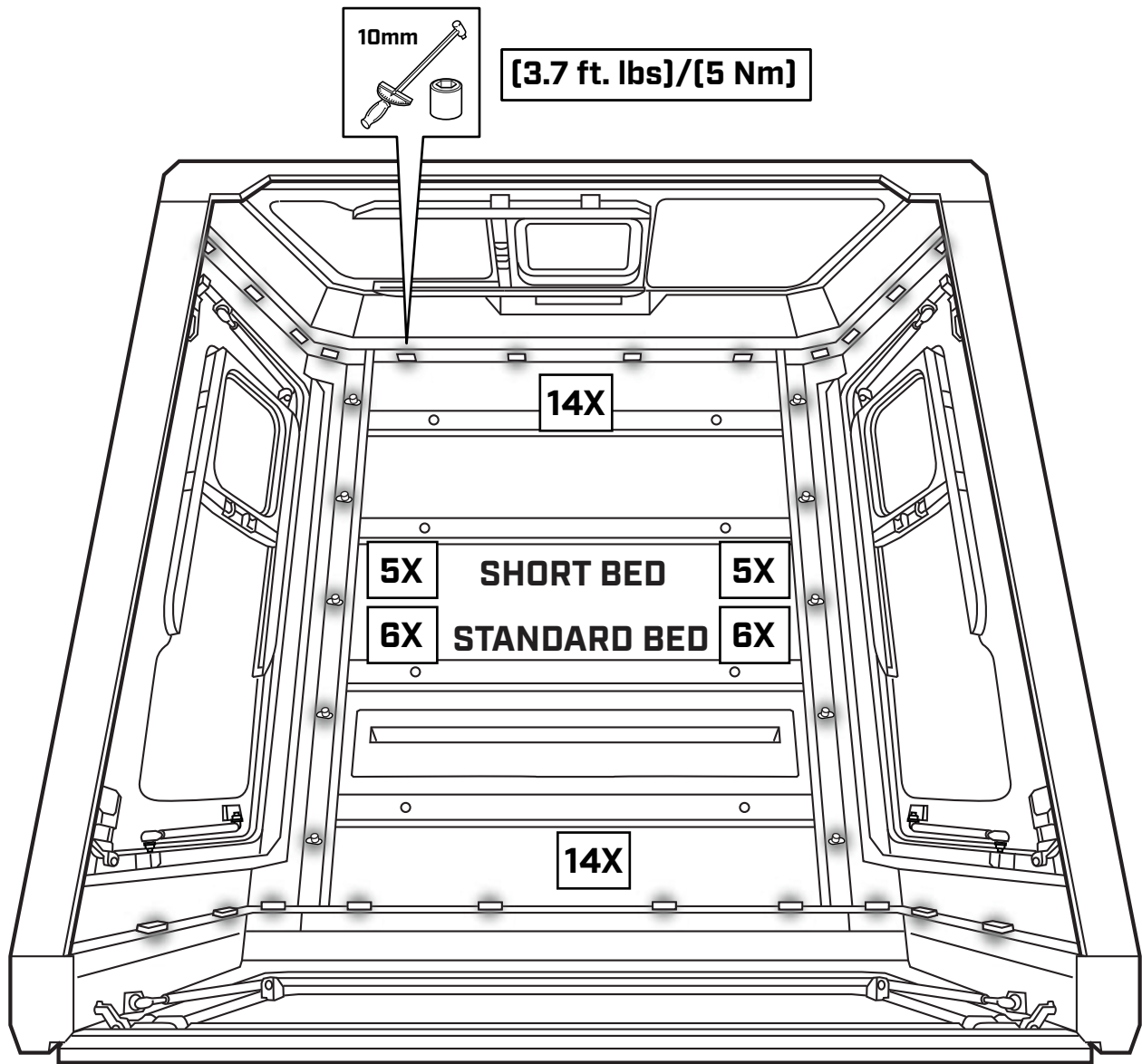

# STEP 21



**REFER TO PG. 3 TO DETERMINE IF YOU HAVE VERSION A OR B**

## VERSION A

- A** LOCATE THE D-RUBBER RETENTION TAB NEXT TO THE REAR DOOR GASKET.  
BEND THE TAB UPWARDS AT A 45 DEGREE ANGLE.

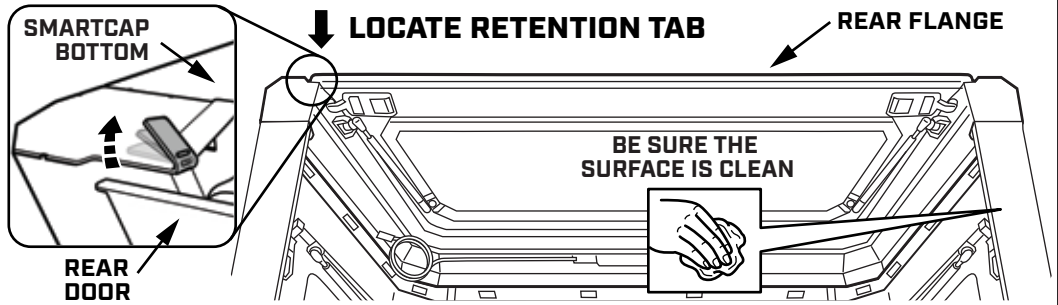

- B** PEEL AWAY A SMALL PORTION OF THE ADHESIVE BACKING FROM THE D-RUBBER.

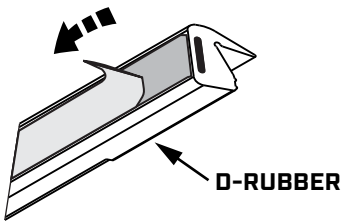

- C** INSERT THE TAB INTO THE D-RUBBER UNTIL THE D-RUBBER LIGHTLY BUTTS UP AGAINST REAR DOOR GASKET.

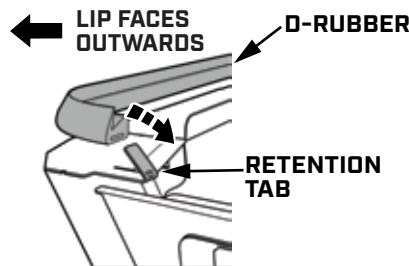

- D** FIRMLY PUSH THE TAB BACK DOWN TO SECURE THE D-RUBBER IN PLACE.

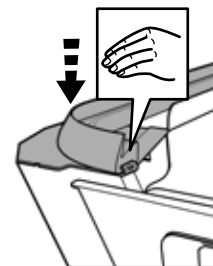

### CORRECT D-RUBBER ORIENTATION

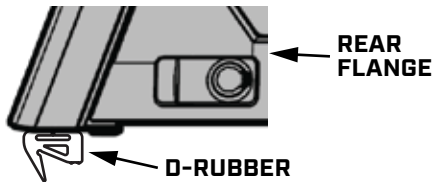

### INCORRECT D-RUBBER ORIENTATION

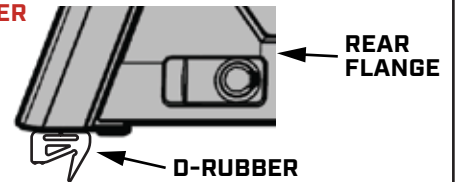

## VERSION B

- APPLY D-RUBBER TO BOTTOM OF SMARTCAP WITH END LIGHTLY BUTTED AGAINST THE REAR DOOR GASKET.

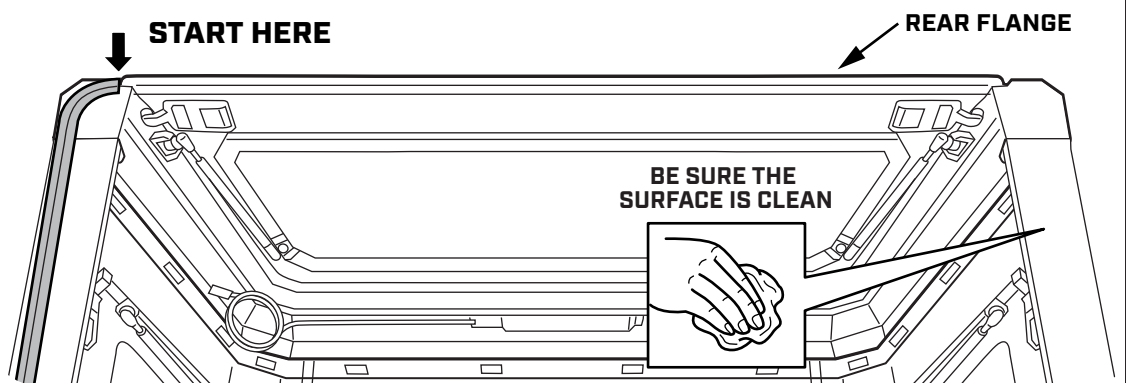

- A** POSITION THE D-RUBBER ALONG THE OUTSIDE EDGE OF THE SMARTCAP.

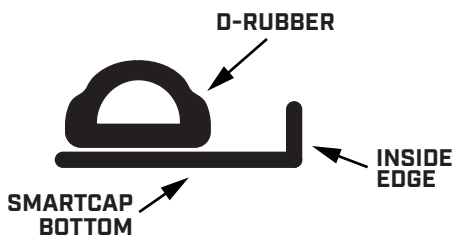

- B** PEEL ADHESIVE BACKING IN SMALL LENGTHS AS YOU WORK AROUND THE SMARTCAP.

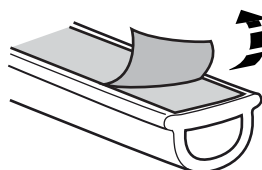

- C** STAY WITHIN 1/8 INCH FROM THE SMARTCAP'S OUTER EDGES.

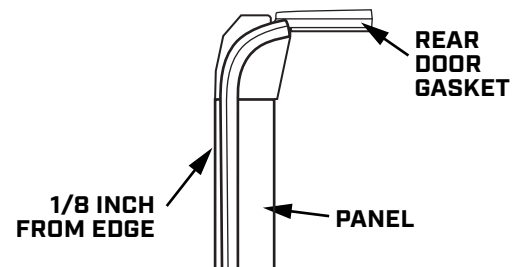

I-SHEET-NA-U2

# STEP 22



**REFER TO PG. 3 TO DETERMINE  
IF YOU HAVE VERSION A OR B**

## VERSION A

PEEL AWAY ADHESIVE BACKING  
IN SHORT LENGTHS AS YOU  
WORK AROUND THE EDGES.

STAY WITHIN 1/8 INCH  
FROM THE SMARTCAP'S  
OUTER EDGES.

REMOVE EXCESS  
WITH A STRAIGHT CUT.

1/8 INCH  
FROM EDGE

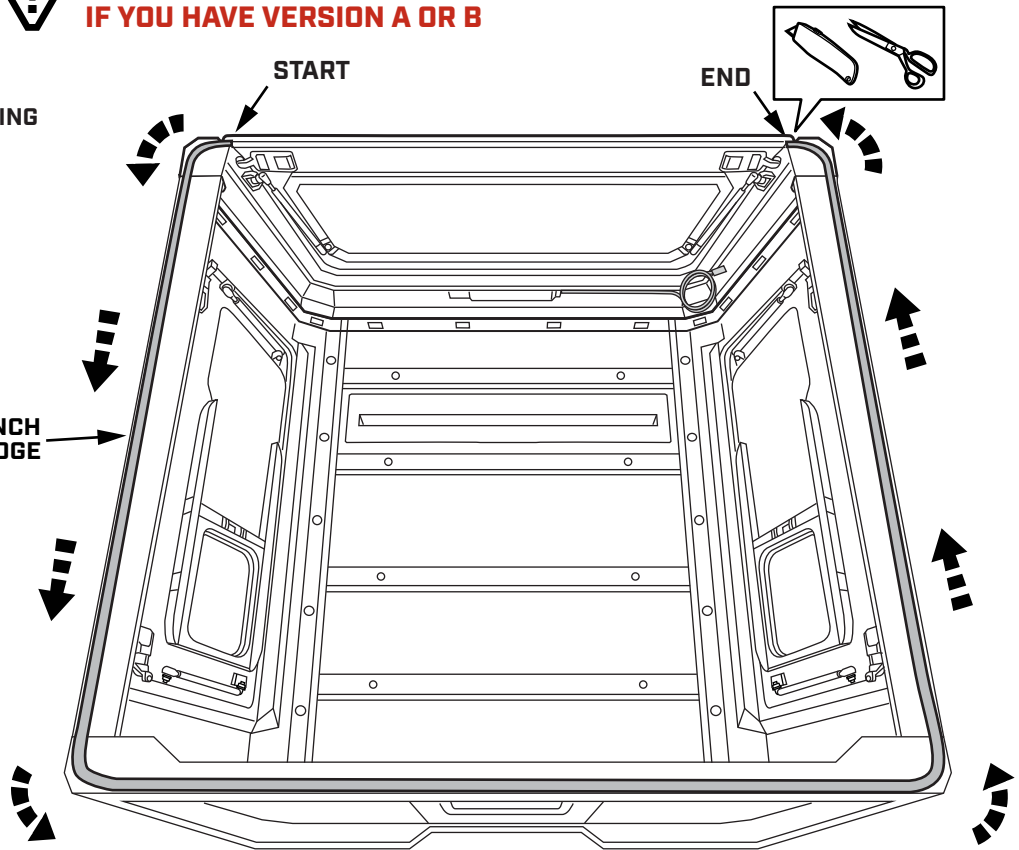

## VERSION B

REMOVE EXCESS  
WITH A STRAIGHT CUT.

REINFORCE THE ENDS  
OF THE D-RUBBER  
WITH SUPERGLUE.

1/8 INCH  
FROM EDGE

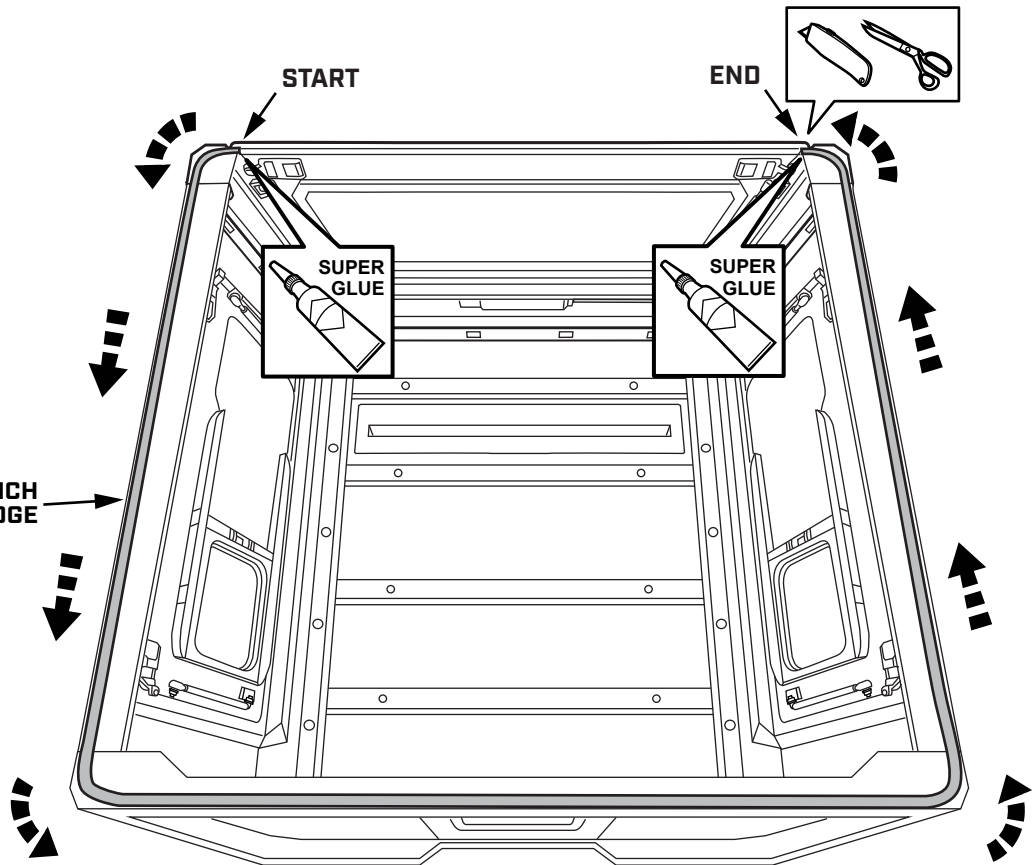

I-SHEET-NA-U2

# INSTALLATION HARDWARE

- GM SILVERADO
- GM COLORADO
- JEEP GLADIATOR  
(WITHOUT TRAIL RAIL)
- RAM 1500 & HEAVY DUTY
- FORD F-SERIES
- TOYOTA TUNDRA  
(WITHOUT DECK RAIL)

THIN RUBBER PAD

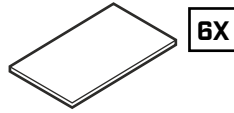

THICK RUBBER PAD

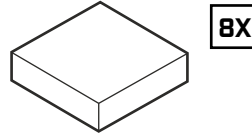

MOUNTING CLAMPS

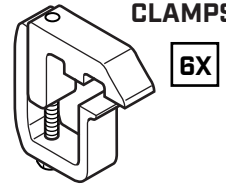

- JEEP GLADIATOR  
(WITH TRAIL RAIL)
- TOYOTA TUNDRA  
(WITH DECK RAIL)
- TOYOTA TACOMA

THIN RUBBER PAD

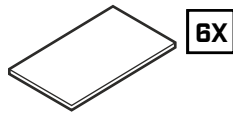

THICK RUBBER PAD

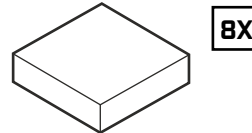

MOUNTING CLAMPS

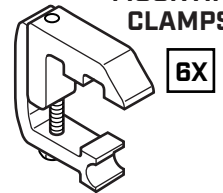

- FORD RANGER

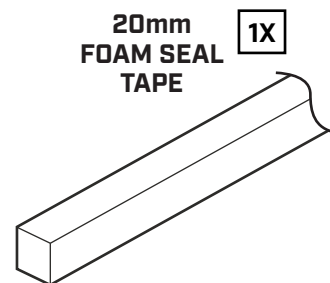
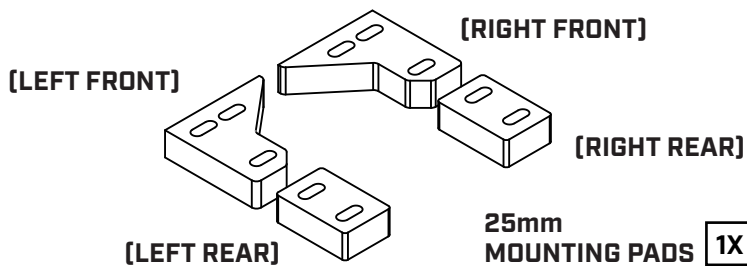
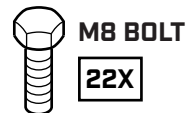
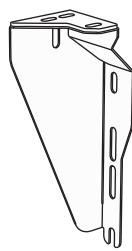
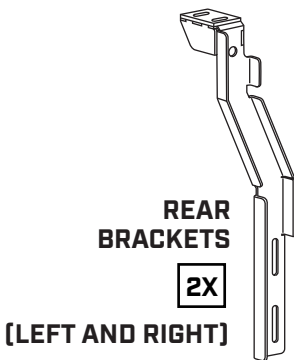

## VEHICLE INSTALLATION



### IMPORTANT

- ▼ ASSISTANCE WILL BE NEEDED FOR THIS INSTALLATION. FOUR PEOPLE ARE RECOMMENDED TO LIFT THE SMARTCAP ONTO THE VEHICLE.
- ▼ AVOID PINCHING OR CRUSHING HANDS AND FINGERS.
- ▼ BE SURE THE VEHICLE IS TURNED OFF FOR THIS INSTALLATION.
- ▼ READ THROUGH THE ENTIRE PROCEDURE BEFORE STARTING AND FOLLOW THE STEPS CAREFULLY TO ENSURE THE THIRD BRAKE LIGHT WILL FUNCTION PROPERLY.
- ▼ USE A TEST LIGHT TO CHECK FOR SUCCESSFUL INSTALLATION.

## THIRD BRAKE LIGHT CONNECTOR INSTALLATION

- ▼ ONCE CAP INSTALLATION IS COMPLETE, CONTINUE TO PAGE 30 FOR THE THIRD BRAKE LIGHT INSTALLATION ON ALL VEHICLES EXCEPT TOYOTA TACOMA AND JEEP GLADIATOR.

# STEP 23-29

### GENERAL APPLICATION

- GM SILVERADO/SIERRA
- GM COLORADO/CANYON
- JEEP GLADIATOR
- RAM 1500 & 2500/3500
- FORD F-SERIES
- TOYOTA TUNDRA

# STEP 30-47

### TOYOTA TACOMA

*YOU WILL NEED THE T-HARNESS FOR THIS INSTALLATION*

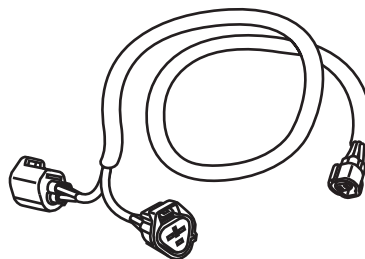

# STEP 48-62

### FORD RANGER

# STEP 23

## GENERAL APPLICATION

REMOVE THE ADHESIVE BACKING FROM THE THICK RUBBER PAD.

PLACE THE PADS ALONG THE INSIDE OF THE D-RUBBER AT THE INDICATED LOCATIONS.

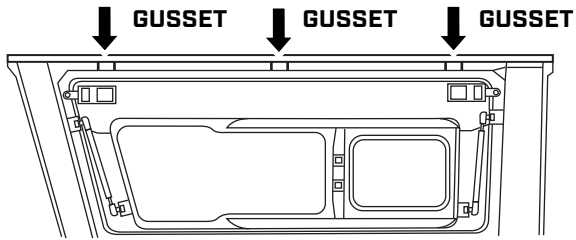
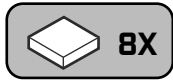

NOTE THE RECOMMENDED LOCATIONS FOR THE MOUNTING CLAMPS INSIDE BOTH SIDES OF THE SMARTCAP

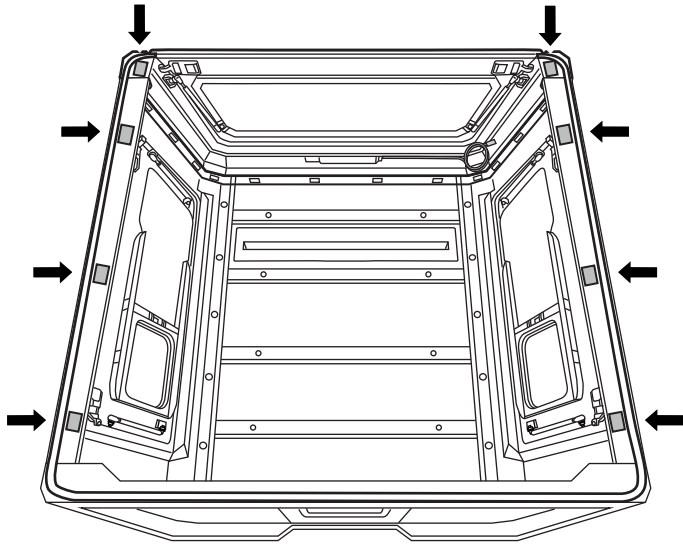

PLACE EXTRA PAD IN EACH REAR CORNER OF THE CAP

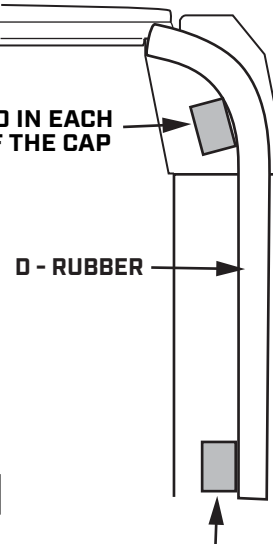

D - RUBBER

THICK RUBBER PAD

THICK RUBBER PAD

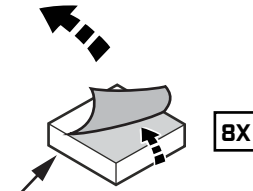

# STEP 24

## GENERAL APPLICATION

INSPECT THE TRUCK BED. IF FRONT EDGE IS LOWER THAN THE SIDES, ADD FOAM SEAL TAPE TO THE FRONT EDGE OF THE BED.

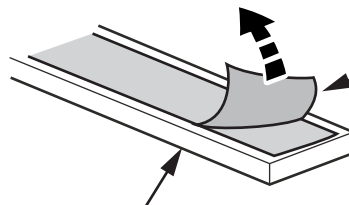
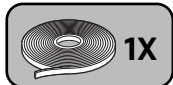

PEEL AWAY ADHESIVE BACKING

5mm FOAM SEAL TAPE

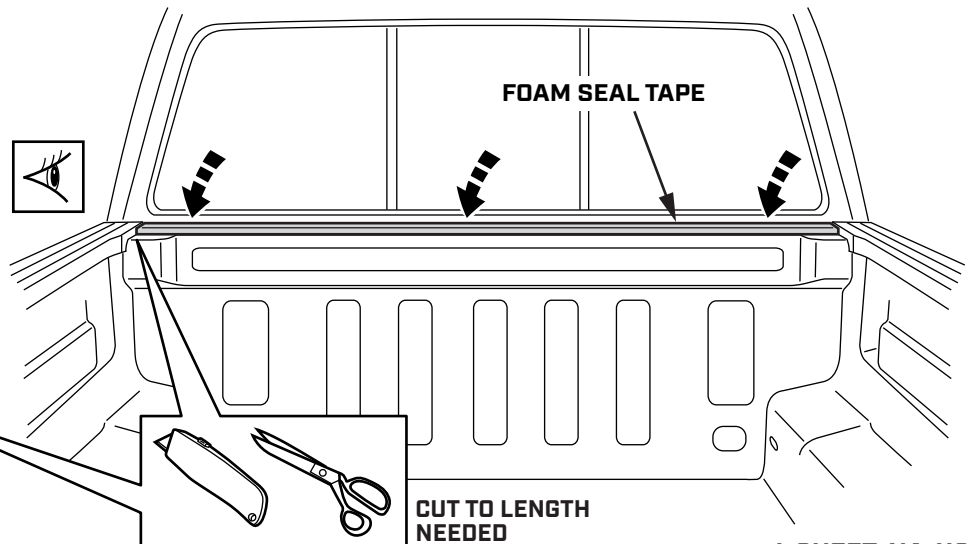

FOAM SEAL TAPE

BE SURE TO FULLY SEAL AT BOTH ENDS

CUT TO LENGTH NEEDED

I-SHEET-NA-U2



## STEP 25

### GENERAL APPLICATION

USE 4 PEOPLE TO LIFT THE ASSEMBLED SMARTCAP ONTO THE TRUCK BED.

TO AVOID DAMAGE TO THE D-RUBBER, DO NOT SLIDE THE SMARTCAP INTO PLACE.

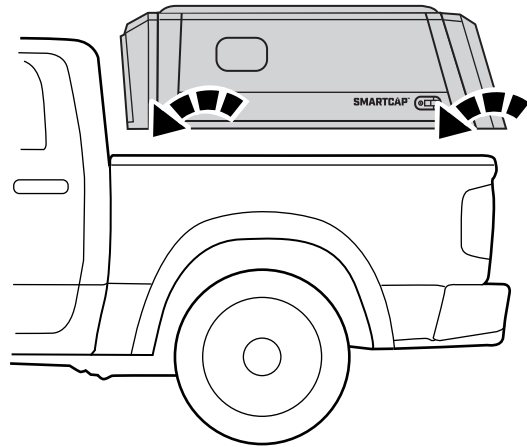
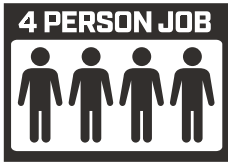

## STEP 26

### GENERAL APPLICATION

CHECK THAT THE SMARTCAP IS PROPERLY POSITIONED AND CENTERED ON THE TRUCK BED.

IT'S IMPORTANT THAT THE SMARTCAP IS NOT PUSHED TOO FAR FORWARD, LEAVING A GAP BETWEEN THE SMARTCAP AND THE CAB.

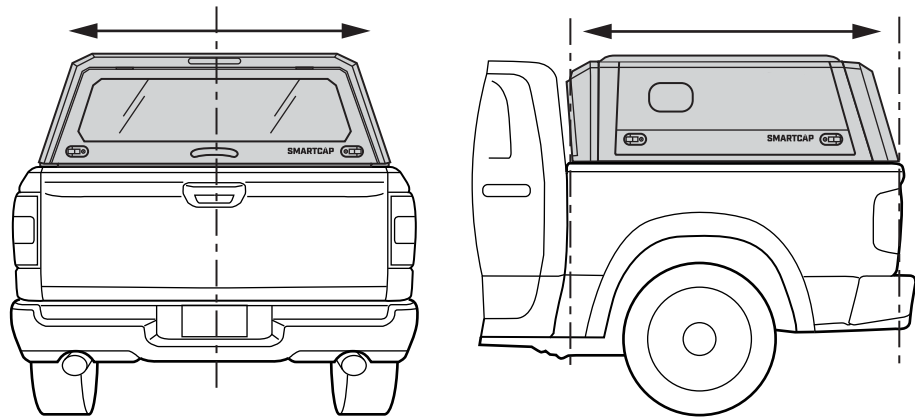

## STEP 27

### GENERAL APPLICATION

WALK AROUND THE TRUCK BED TO MAKE SURE THE D-RUBBER FITMENT IS CORRECT AND THAT THE RUBBER LIP IS PROPERLY TUCKED UNDERNEATH THE CAP.

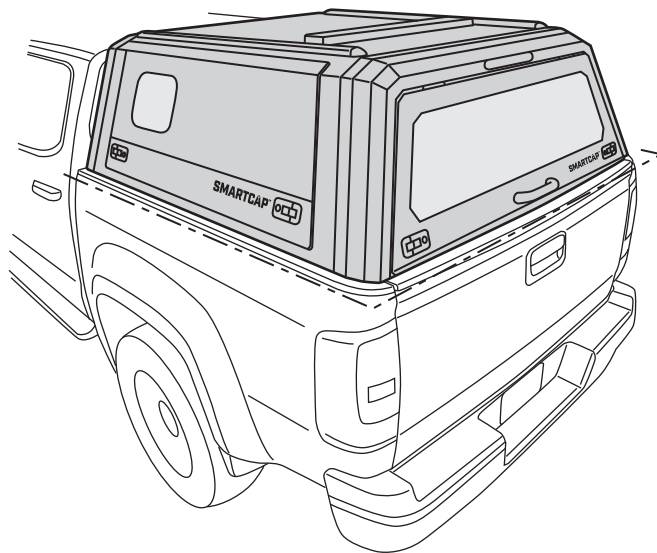

*\*YOU MAY NOTICE THAT THE SEAL ON THE SLIDING PORTAL WINDOW MIGHT APPEAR WRINKLED. THIS IS DUE TO THE ANTI-SLIP COATING AND IS NOT A CAUSE FOR CONCERN.*

**I-SHEET-NA-U2**

# STEP 28

## GENERAL APPLICATION

WITH THE EXCEPTION OF THE REAR CORNERS, PLACE THE THIN RUBBER PADS NEXT TO GUSSETS ON BOTH SIDES OF THE CAP.

**3 PADS PER SIDE**

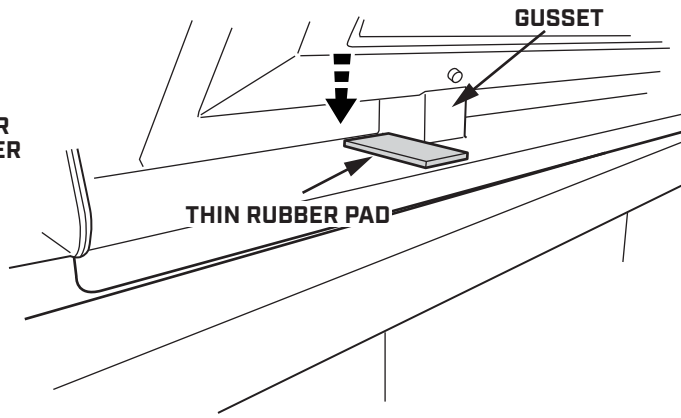

# STEP 29-A

## GENERAL APPLICATION WITHOUT DECK RAILS

ONCE ALL PADS ARE IN PLACE, INSTALL AND TIGHTEN MOUNTING CLAMPS USING TORQUE WRENCH AND 13MM SOCKET TO 4.4 FT. LBS. [6 NEWTON METERS]

**3 CLAMPS PER SIDE**

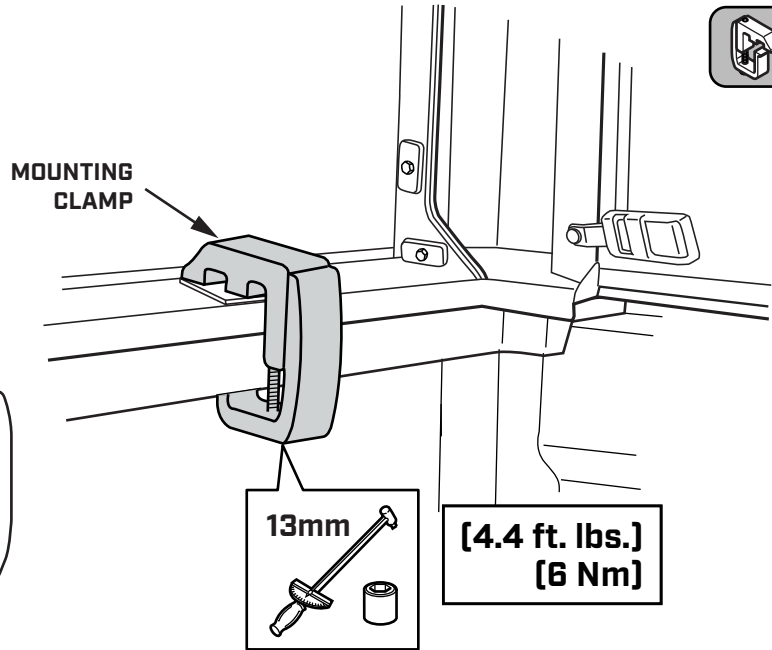
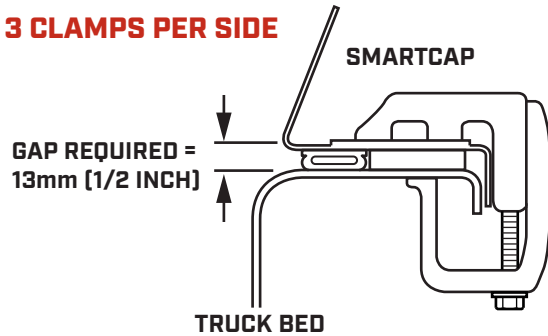

# STEP 29-B

**YOUR CAP INSTALLATION IS COMPLETE, CONTINUE TO PAGE 30 FOR THE THIRD BRAKE LIGHT INSTALLATION.**

## GENERAL APPLICATION WITH DECK RAILS

DISASSEMBLE MOUNTING CLAMPS.

INSTALL LOWER CLAMP ARMS INTO RAIL INSIDE TRUCK BED AND SET THEM IN FRONT OF EVERY THIN RUBBER PAD.

**3 CLAMPS PER SIDE**

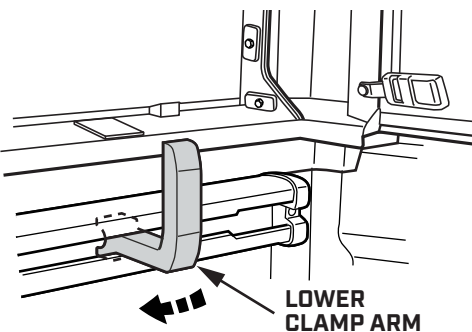

REASSEMBLE UPPER AND LOWER CLAMP ARMS.

HAND TIGHTEN ALL MOUNTING CLAMPS.

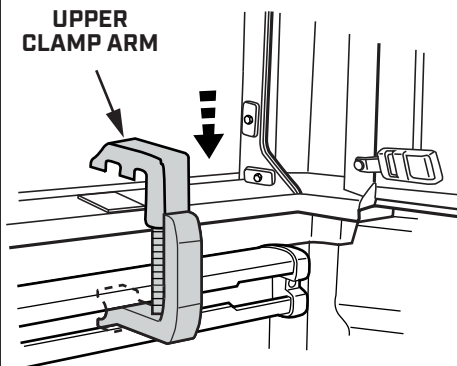

TIGHTEN MOUNTING CLAMPS USING TORQUE WRENCH AND 13MM SOCKET TO 4.4 FT. LBS. [6 NEWTON METERS]

GAP REQUIRED: 13mm (1/2 INCH)

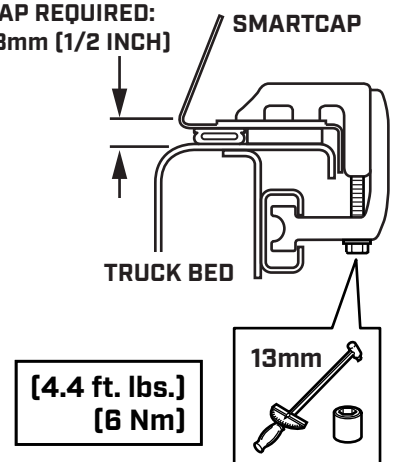

# STEP 30

## TOYOTA TACOMA

REMOVE THE ADHESIVE BACKING FROM THE THICK RUBBER PAD.

PLACE THE PADS ALONG THE INSIDE OF THE D-RUBBER AT THE INDICATED LOCATIONS.

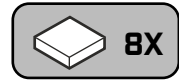
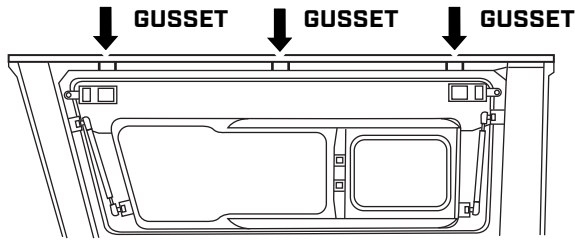
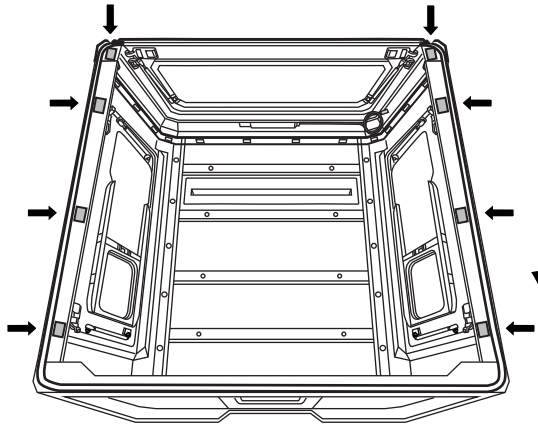

NOTE THE RECOMMENDED LOCATIONS FOR THE MOUNTING CLAMPS INSIDE BOTH SIDES OF THE SMARTCAP

PLACE EXTRA PAD IN EACH REAR CORNER OF THE CAP

D - RUBBER

THICK RUBBER PAD

# STEP 31

## TOYOTA TACOMA

DISCONNECT THE EXTENSION HARNESS FROM THE SMARTCAP.

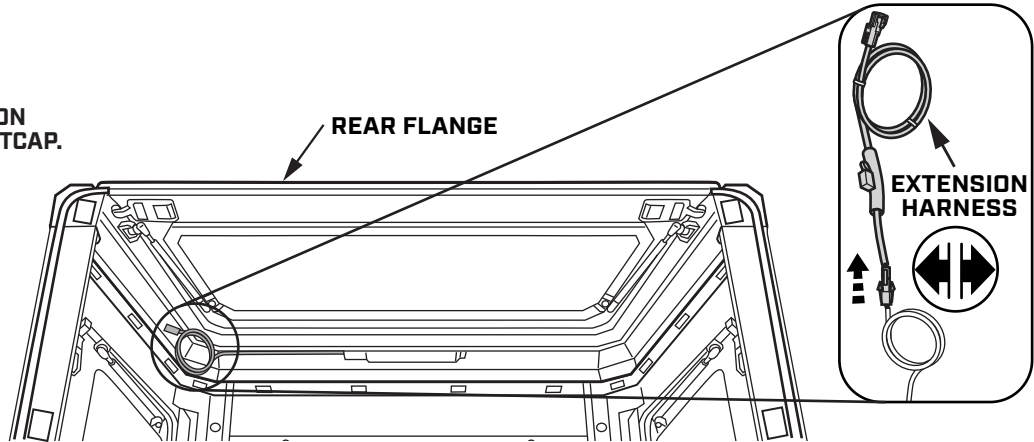

# STEP 32

## TOYOTA TACOMA

REMOVE THE BOLTS HOLDING THE DRIVER SIDE TAILLIGHT ASSEMBLY.

TAILLIGHT ASSEMBLY

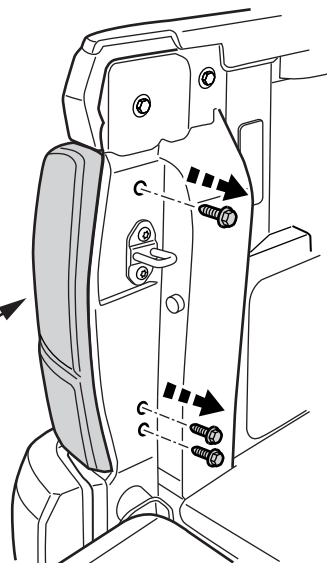

# STEP 33

## TOYOTA TACOMA

PLACE THE TAILLIGHT ASSEMBLY CAREFULL ON THE TAILGATE. DO NOT UNPLUG ANY CONNECTORS.

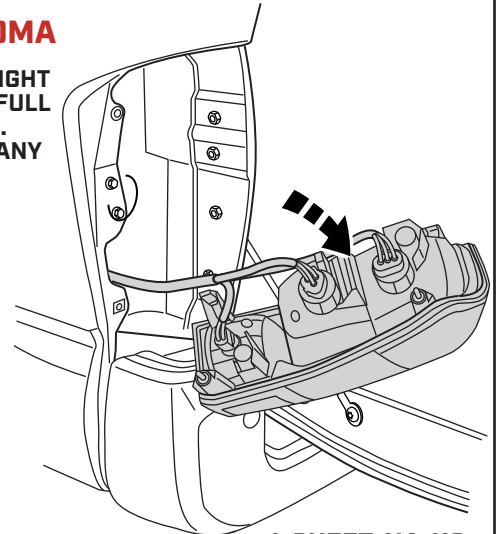

I-SHEET-NA-U2

## STEP 34

### TOYOTA TACOMA

CAREFULLY PULL UP ON THE TOP EDGE PANEL OF THE TRUCK BED TO LOCATE THE HOLE IN THE SHEET METAL.

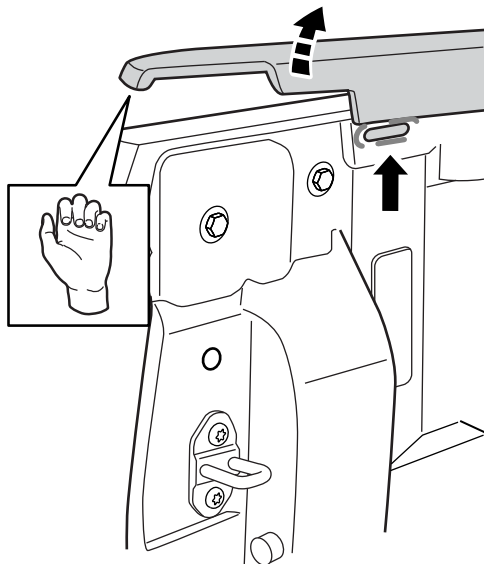

## STEP 35

### TOYOTA TACOMA

ROUTE THE EXTENSION HARNESS THROUGH THE HOLE AND BACK TOWARDS THE TAILLIGHT OPENING.

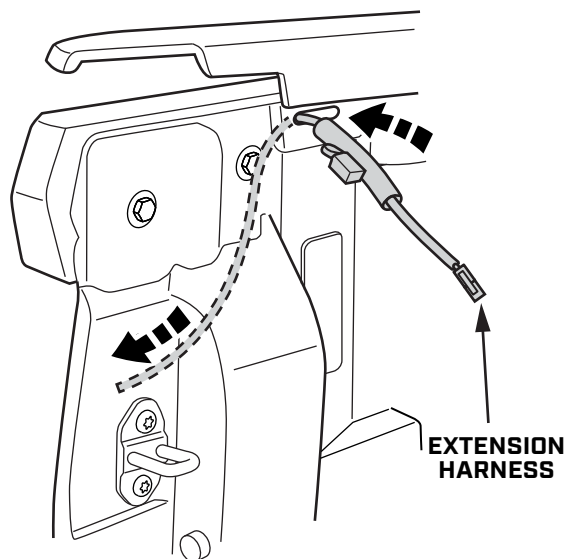

## STEP 36

### TOYOTA TACOMA

DISCONNECT THE MIDDLE BRAKE LIGHT PLUG AT THE BACK OF THE TAILLIGHT ASSEMBLY.

TAILLIGHT CAVITY

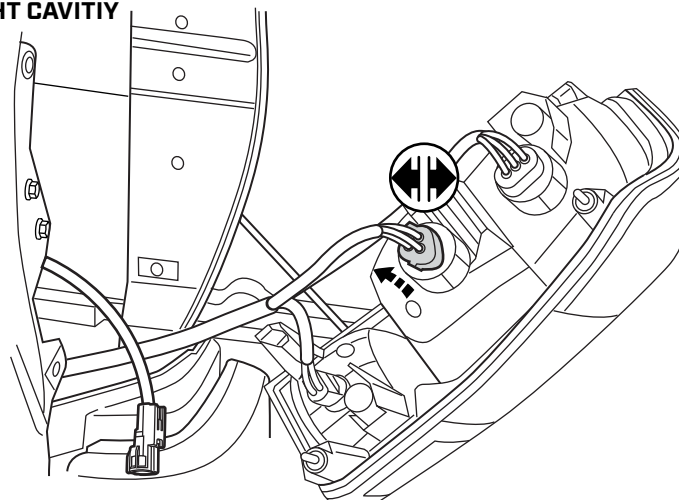

I-SHEET-NA-U2

# STEP 37

## TOYOTA TACOMA

CONNECT THE BRAKE LIGHT PLUG INTO THE FEMALE PLUG FROM THE T-HARNESS.

CONNECT THE MALE PLUG FROM THE T-HARNESS INTO THE FEMALE BRAKE LIGHT SOCKET.

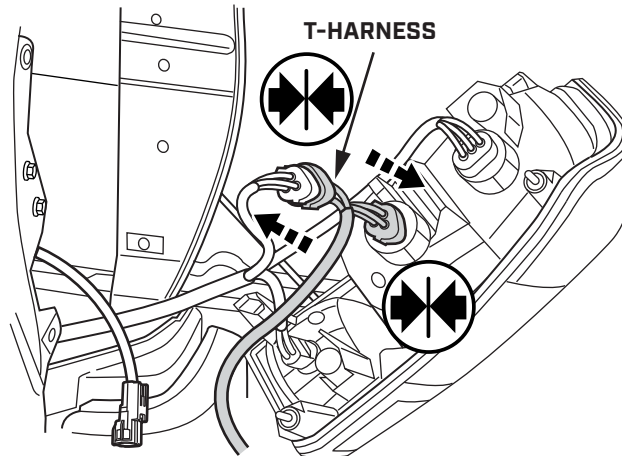
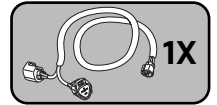

# STEP 38

## TOYOTA TACOMA

CONNECT THE T-HARNESS TO THE EXTENSION HARNESS.

EXTENSION HARNESS

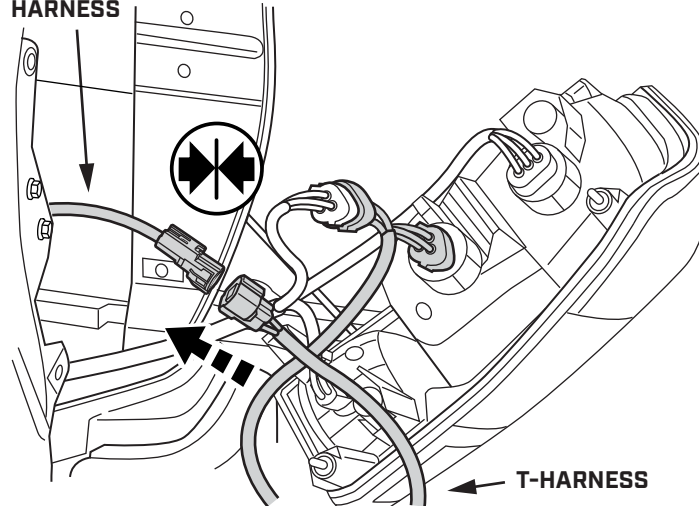

# STEP 39

## TOYOTA TACOMA

BUNDLE EXTRA T-HARNESS LENGTH IN THE TAILLIGHT CAVITY AND SECURE WITH CABLE TIES.

REINSTALL THE TAILLIGHT ASSEMBLY.

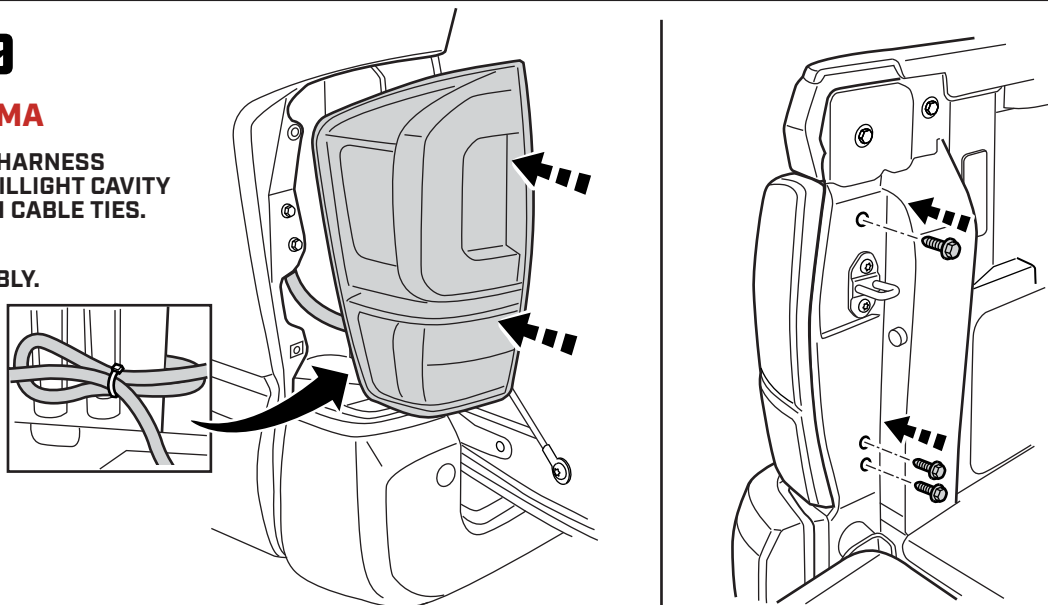

I-SHEET-NA-U2

# STEP 40

## TOYOTA TACOMA

USE 4 PEOPLE TO LIFT THE ASSEMBLED SMARTCAP ONTO THE TRUCK BED.

TO AVOID DAMAGE TO THE D-RUBBER, DO NOT SLIDE THE SMARTCAP INTO PLACE.

4 PERSON JOB

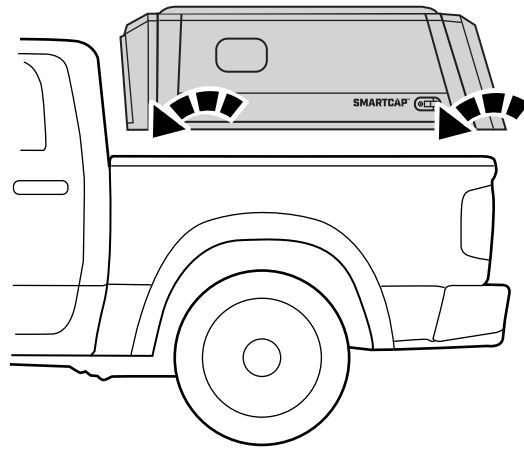

# STEP 41

## TOYOTA TACOMA

CHECK THAT THE SMARTCAP IS PROPERLY POSITIONED AND CENTERED ON THE TRUCK BED.

IT'S IMPORTANT THAT THE SMARTCAP IS NOT PUSHED TOO FAR FORWARD, LEAVING A GAP BETWEEN THE SMARTCAP AND THE CAB.

4 PERSON JOB

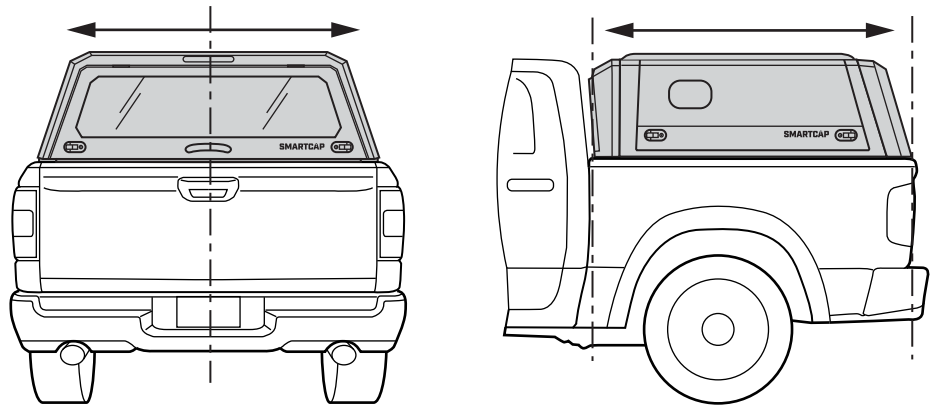

# STEP 42

## TOYOTA TACOMA

WALK AROUND THE TRUCK BED TO MAKE SURE THE D-RUBBER FITMENT IS CORRECT AND THAT THE RUBBER LIP IS PROPERLY TUCKED UNDERNEATH THE CAP.

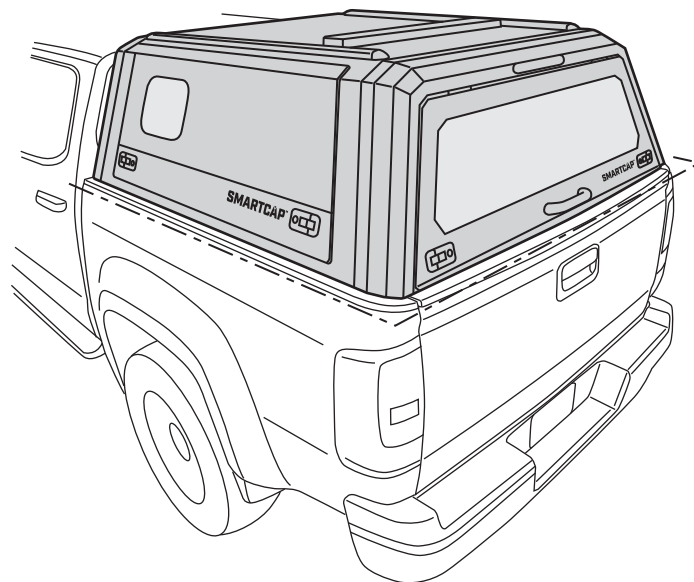

\*YOU MAY NOTICE THAT THE SEAL ON THE SLIDING PORTAL WINDOW MIGHT APPEAR WRINKLED. THIS IS DUE TO THE ANTI-SLIP COATING AND IS NOT A CAUSE FOR CONCERN.

# STEP 43

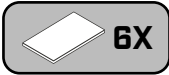

## TOYOTA TACOMA

WITH THE EXCEPTION OF THE REAR CORNERS, PLACE THE THIN RUBBER PADS NEXT TO GUSSETS ON BOTH SIDES OF THE CAP.

**3 PADS PER SIDE**

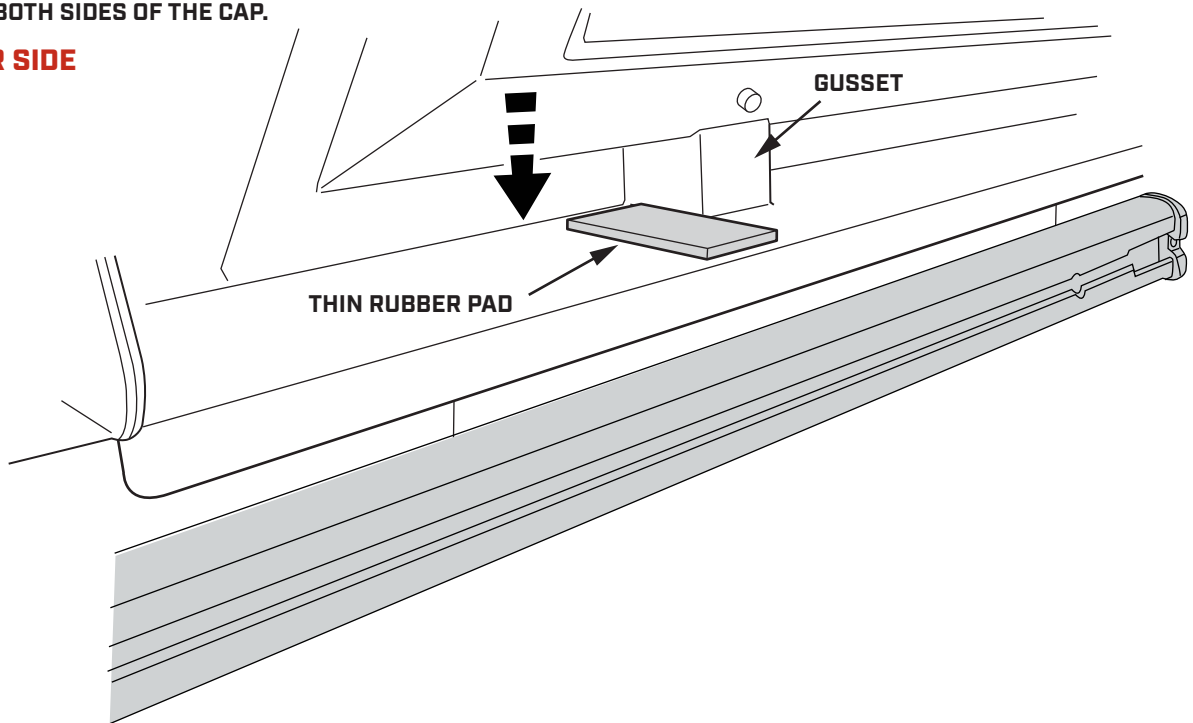

# STEP 44



## TOYOTA TACOMA

DISASSEMBLE MOUNTING CLAMPS.

INSTALL LOWER CLAMP ARMS INTO RAIL INSIDE TRUCK BED AND SET THEM IN FRONT OF EVERY THIN RUBBER PAD.

**3 CLAMPS PER SIDE**

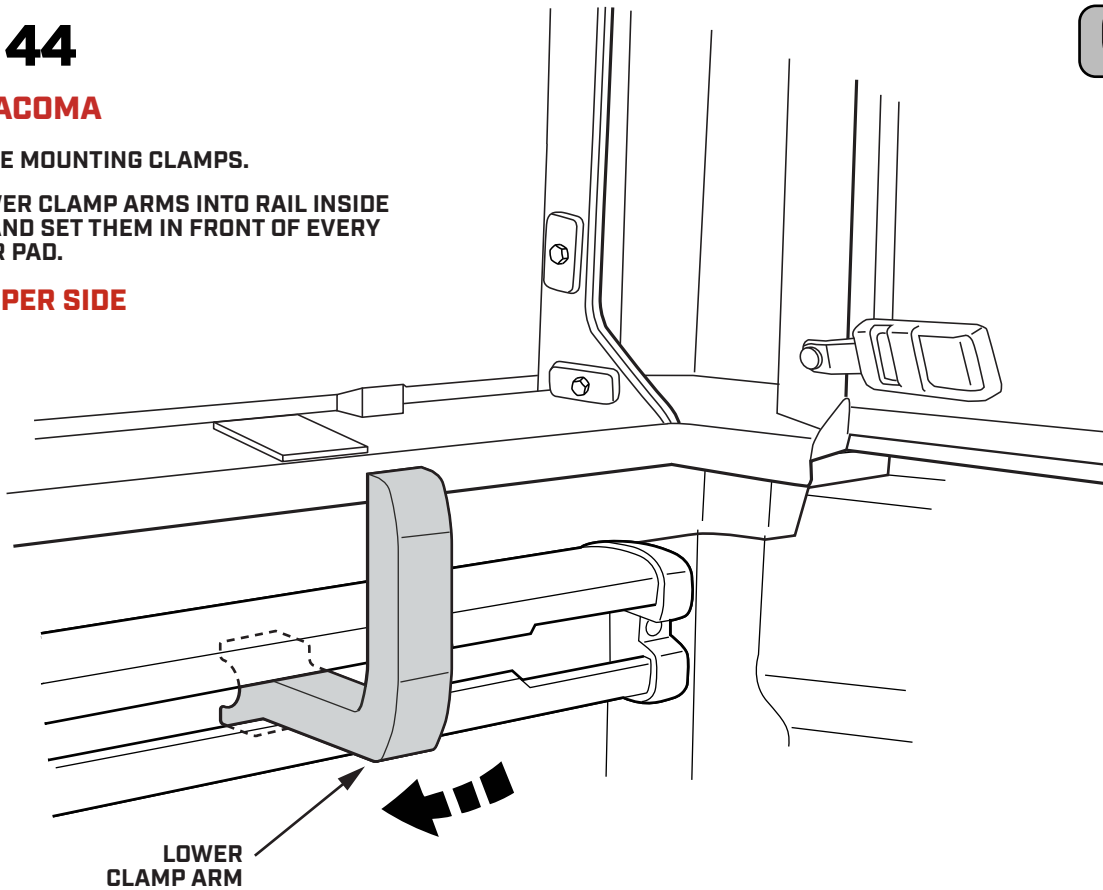

I-SHEET-NA-U2

## STEP 45

### TOYOTA TACOMA

REASSEMBLE UPPER AND LOWER CLAMP ARMS.

HAND TIGHTEN ALL MOUNTING CLAMPS.

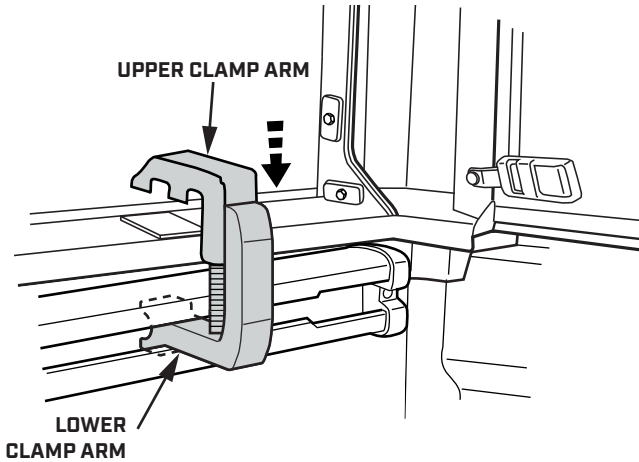

TIGHTEN MOUNTING CLAMPS USING TORQUE WRENCH AND 13MM SOCKET TO 4.4 FT. LBS. [6 NEWTON METERS]

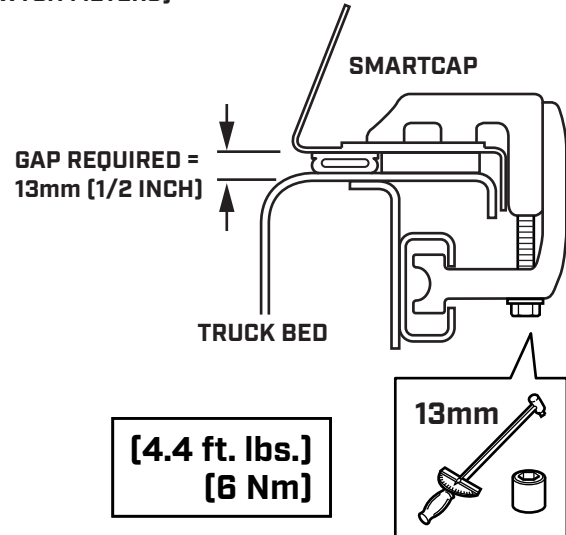

## STEP 46

### TOYOTA TACOMA

CONNECT THE EXTENSION HARNESS TO THE SMARTCAP'S THIRD BRAKE LIGHT HARNESS.

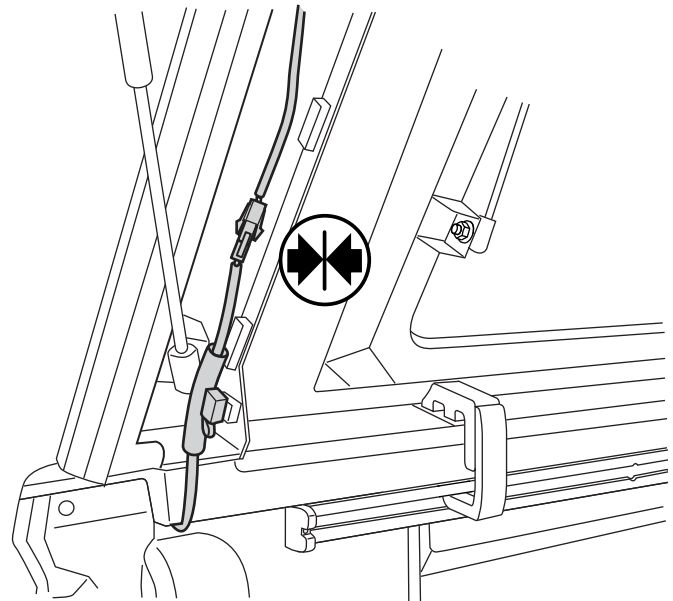

## STEP 47



### TEST YOUR BRAKE LIGHTS & TURN SIGNALS

- ▼ START THE TRUCK. SOME MODELS MAY TAKE UP TO 30 SECONDS FOR THE VEHICLE TO DETECT THE NEW CONNECTION.
- ▼ CHECK THE BRAKE LIGHTS AND TURN SIGNALS TO BE SURE THEY ARE FUNCTIONING PROPERLY.
- ▼ ONCE YOU HAVE CONFIRMED THAT THE LIGHTS ARE WORKING CORRECTLY, SECURE THE HARNESS WITH CABLE TIES.
- ▼ BE SURE NOT TO INTERFERE WITH ANY MOVING PARTS ON THE VEHICLE.
- ▼ YOU CAP INSTALLATION IS COMPLETE. YOU CAN FIND SMARTCAP CONTACT INFORMATION ON PAGE 39.



# STEP 48

## FORD RANGER

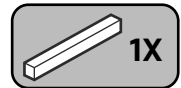

INSPECT THE TRUCK BED. IF FRONT EDGE IS LOWER THAN THE SIDES, ADD FOAM SEAL TAPE TO THE FRONT EDGE OF THE BED.

20mm FOAM SEAL TAPE

PEEL AWAY ADHESIVE BACKING

FOAM SEAL TAPE

BE SURE TO FULLY SEAL AT BOTH ENDS

CUT TO LENGTH NEEDED

# STEP 49

## FORD RANGER

REMOVE THE FRONT TIE DOWN HOOK FROM THE INNER WALL OF THE TRUCK BED.

HAND TIGHTEN LEFT AND RIGHT FRONT MOUNTING BRACKETS TO THE TRUCK BED WITH M8 BOLT, M8 LOCK WASHER, TIE DOWN HOOK AND M8 FENDER WASHER AS SHOWN.

FRONT MOUNTING BRACKET

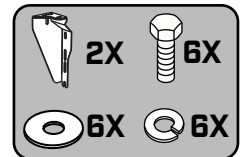

M8 FENDER WASHER

M8 LOCK WASHER

M8 BOLT



I-SHEET-NA-U2

# STEP 50

## FORD RANGER

REMOVE THE REAR TIE DOWN HOOK FROM THE INNER WALL OF THE TRUCK BED.

HAND TIGHTEN LEFT AND RIGHT REAR MOUNTING BRACKETS TO THE TRUCK BED WITH M8 BOLT, M8 LOCK WASHER, TIE DOWN HOOK AND M8 FENDER WASHER AS SHOWN.

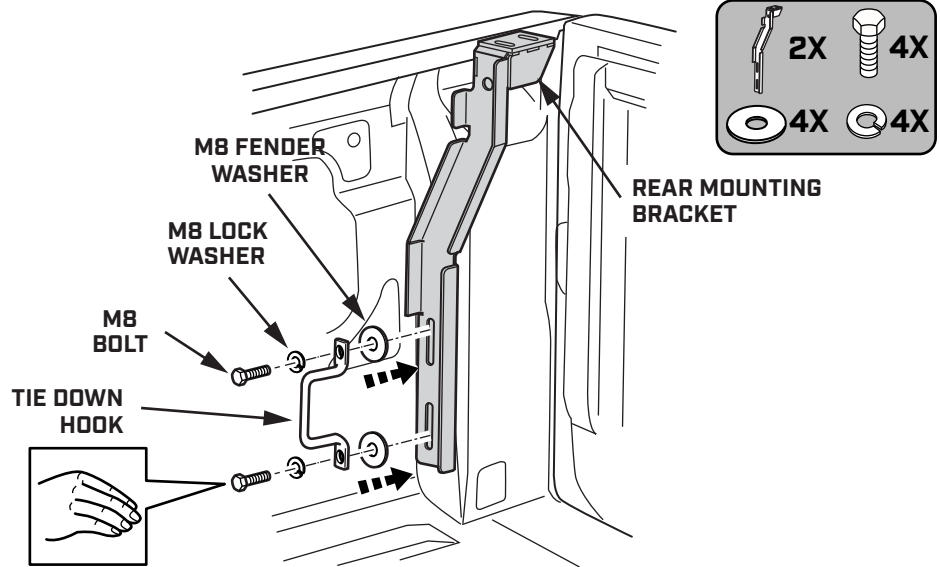

# STEP 51

## FORD RANGER

POSITION THE FRONT MOUNTING PADS ON TOP OF LEFT AND RIGHT FRONT MOUNTING BRACKETS AS SHOWN.

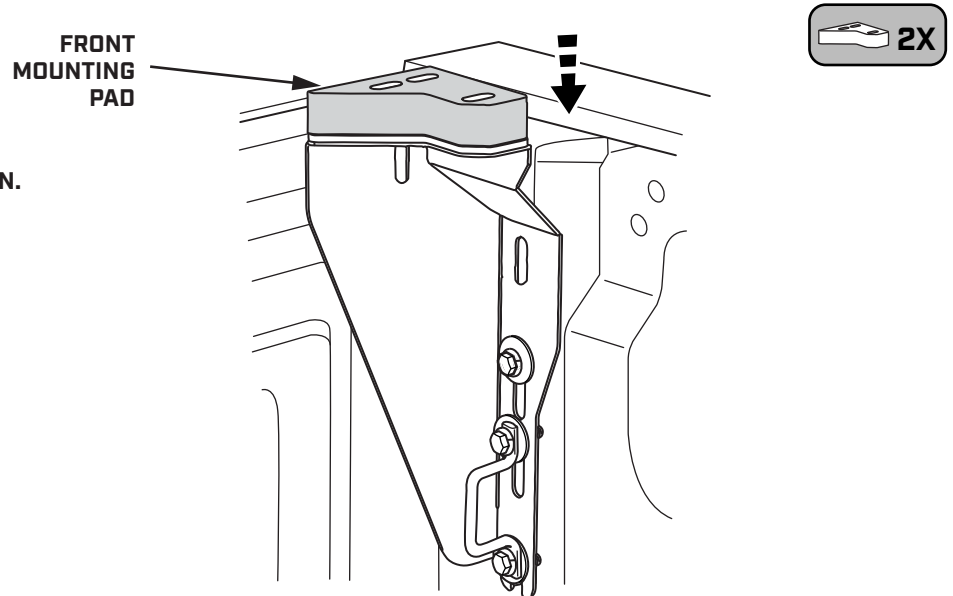

# STEP 52

## FORD RANGER

POSITION THE REAR MOUNTING PADS ON TOP OF LEFT AND RIGHT REAR MOUNTING BRACKETS AS SHOWN.

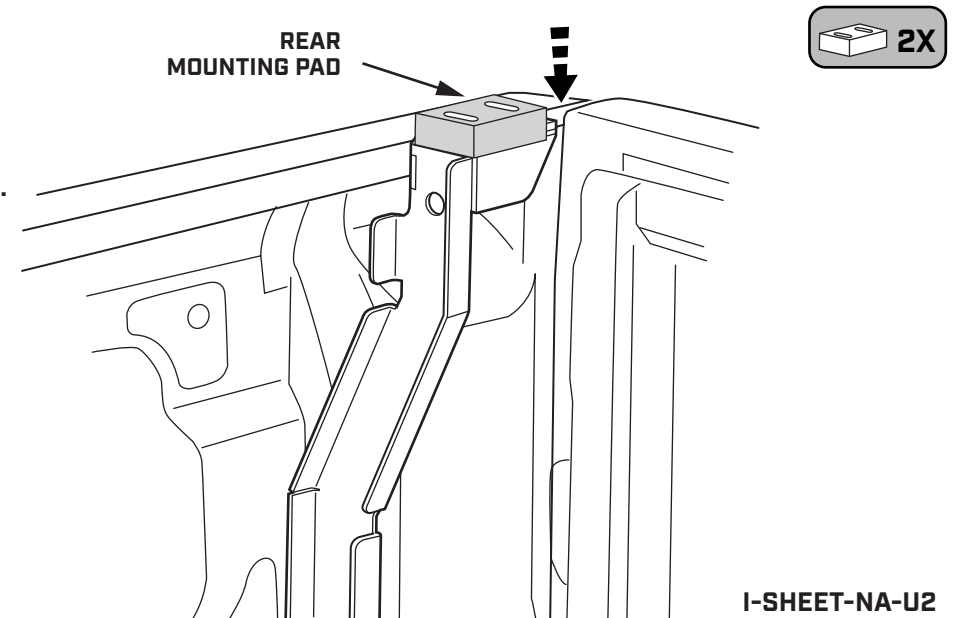

# STEP 53

## FORD RANGER

USE 4 PEOPLE TO LIFT THE ASSEMBLED SMARTCAP ONTO THE TRUCK BED.

TO AVOID DAMAGE TO THE D-RUBBER, DO NOT SLIDE THE SMARTCAP INTO PLACE.

4 PERSON JOB

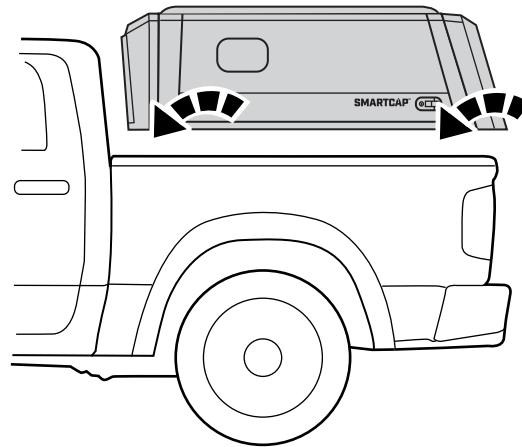

# STEP 54

## FORD RANGER

CHECK THAT THE SMARTCAP IS PROPERLY POSITIONED AND CENTERED ON THE TRUCK BED.

IT'S IMPORTANT THAT THE SMARTCAP IS NOT PUSHED TOO FAR FORWARD, LEAVING A GAP BETWEEN THE SMARTCAP AND THE CAB.

4 PERSON JOB

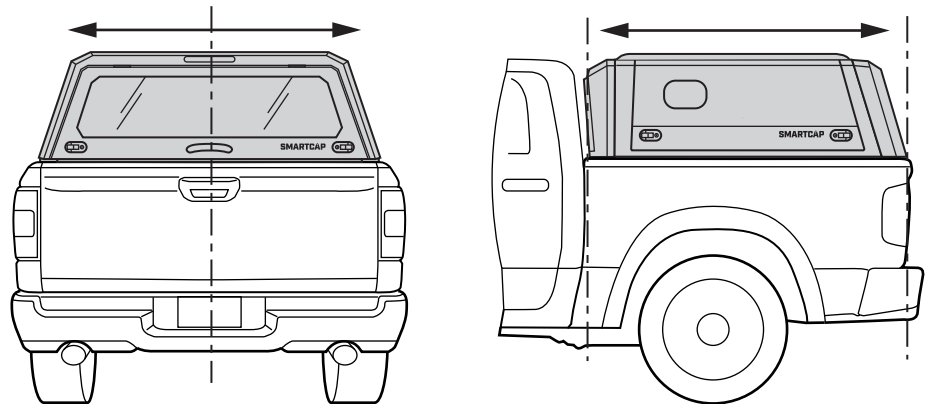

# STEP 55

## FORD RANGER

WALK AROUND THE TRUCK BED TO MAKE SURE THE D-RUBBER FITMENT IS CORRECT AND THAT THE RUBBER LIP IS PROPERLY TUCKED UNDERNEATH THE CAP.

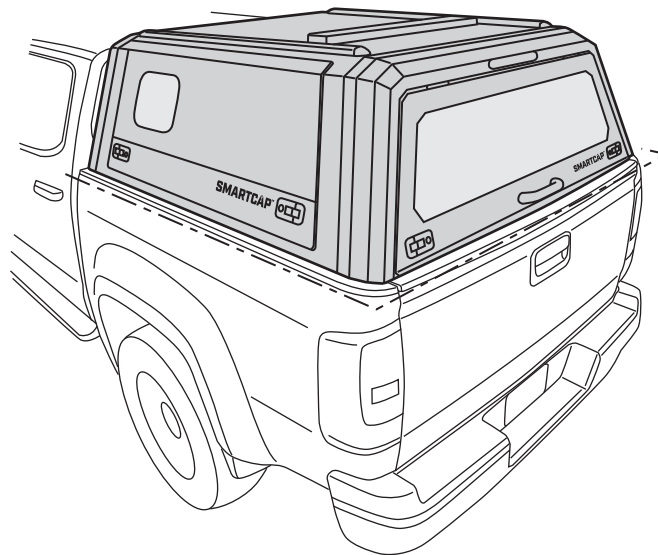

*\*YOU MAY NOTICE THAT THE SEAL ON THE SLIDING PORTAL WINDOW MIGHT APPEAR WRINKLED. THIS IS DUE TO THE ANTI-SLIP COATING AND IS NOT A CAUSE FOR CONCERN.*

I-SHEET-NA-U2

# STEP 56

## FORD RANGER

SECURE LEFT AND RIGHT FRONT MOUNTING BRACKETS TO THE SMARTCAP USING M8 BOLTS, M8 FENDER WASHERS AND M8 LOCK NUTS AS SHOWN, HAND TIGHTEN ONLY.

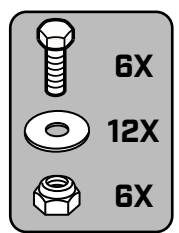
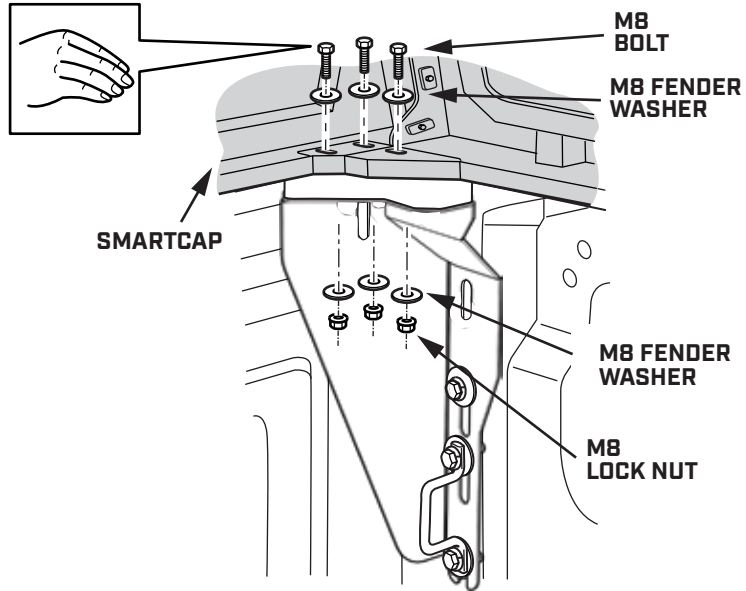

# STEP 57

## FORD RANGER

SECURE LEFT AND RIGHT REAR MOUNTING BRACKETS TO THE SMARTCAP USING M8 BOLTS, M8 FENDER WASHERS AND M8 LOCK NUTS AS SHOWN, HAND TIGHTEN ONLY.

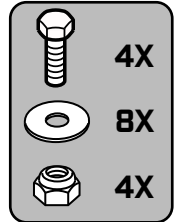
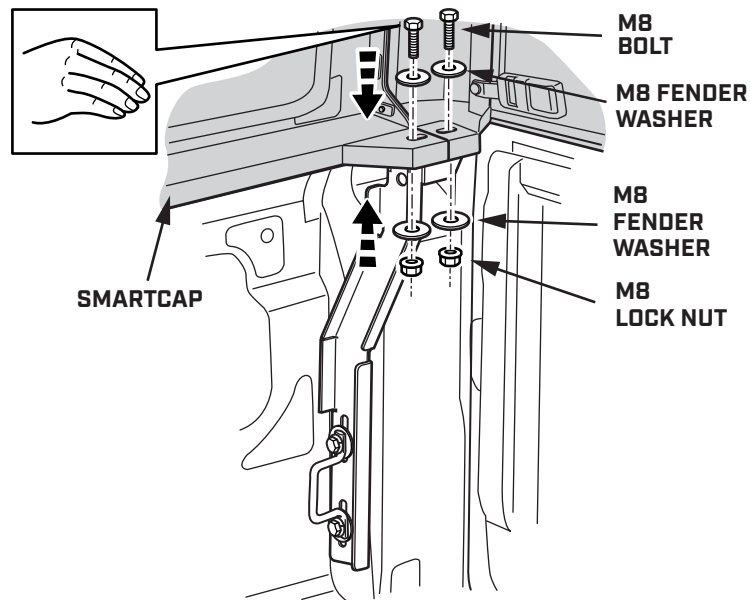

# STEP 58

## FORD RANGER

PARTIALLY TIGHTEN FASTENERS FOR ALL MOUNTING BRACKETS USING THE SOCKET WRENCH AND 13MM SOCKET.

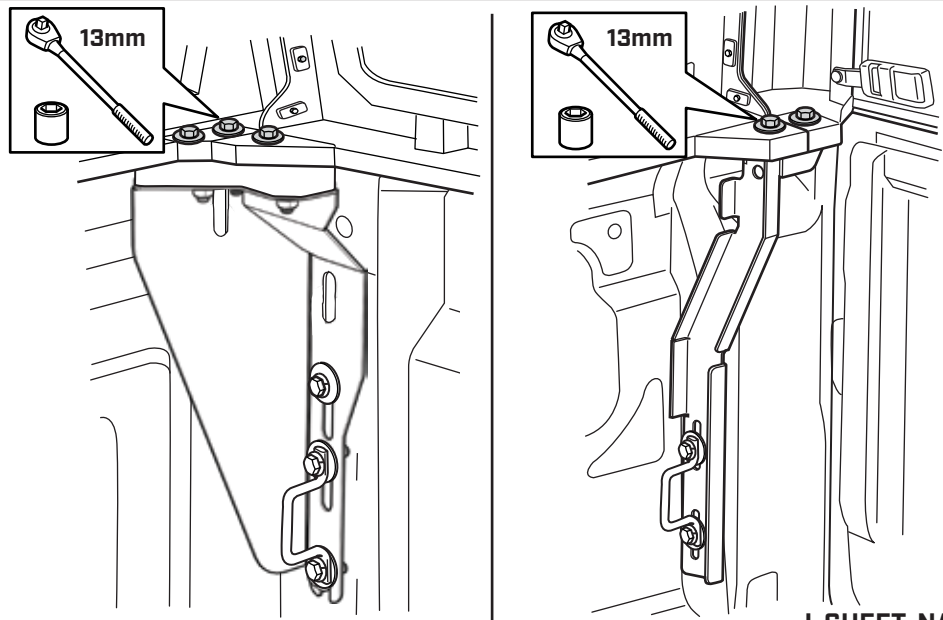

# STEP 59

## FORD RANGER

PRESS DOWN ON THE SMARTCAP TO ACHIEVE 2MM - 3MM COMPRESSION ON D-RUBBER AND PARTIALLY TIGHTEN ALL BRACKET FASTENERS ON ALL FOUR CORNERS WITH SOCKET WRENCH AND 13MM SOCKET.

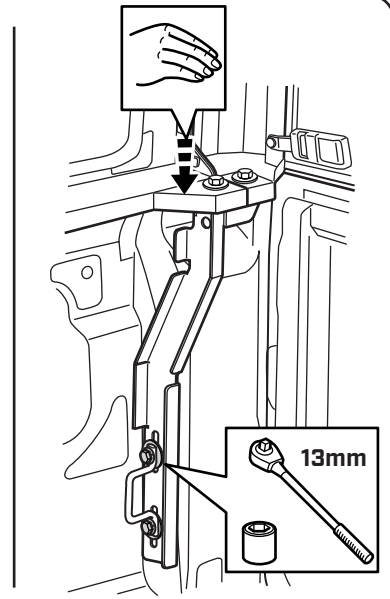
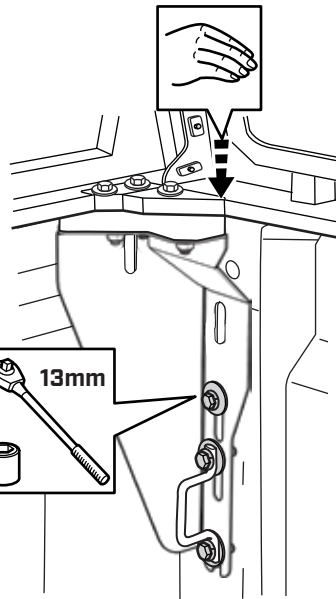
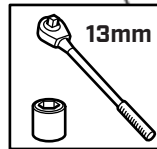
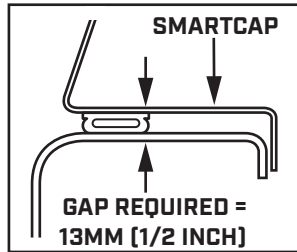

# STEP 60

## FORD RANGER

FULLY TIGHTEN ALL BRACKET FASTENERS ON ALL FOUR CORNERS TO THE SMARTCAP WITH A TORQUE WRENCH AND 13MM SOCKET TO 4.4 FT. LBS. OF TORQUE (6 NEWTON METERS).



[4.4 ft. lbs.]  
[6 Nm]

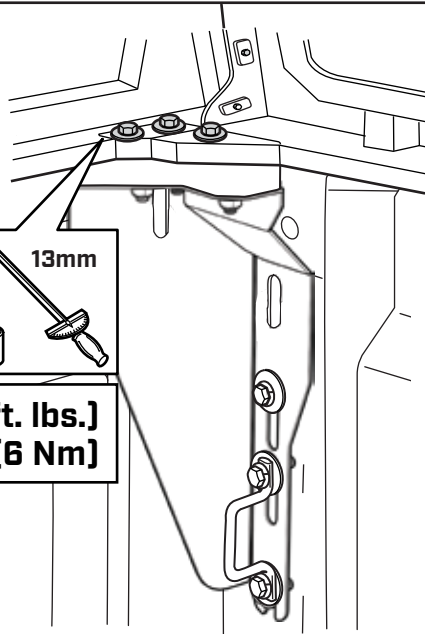

[4.4 ft. lbs.]  
[6 Nm]

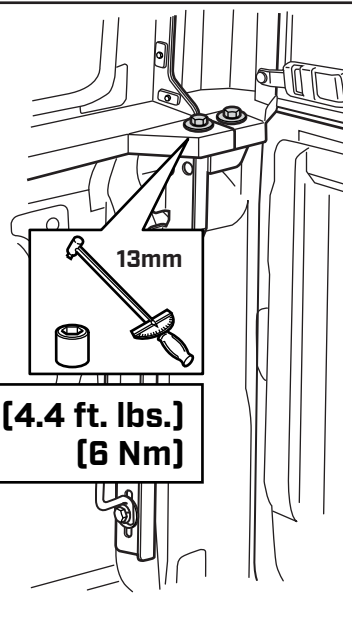

# STEP 61

## FORD RANGER

FULLY TIGHTEN BRACKET FASTENERS ON ALL FOUR CORNERS TO THE TRUCK BED WITH A TORQUE WRENCH AND 13MM SOCKET TO 9 FT. LBS. OF TORQUE (12.2 NEWTON METERS).

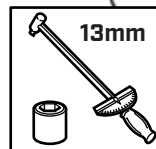

[9 ft. lbs.]  
[12.2 Nm]

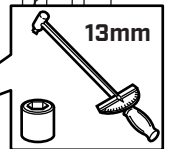
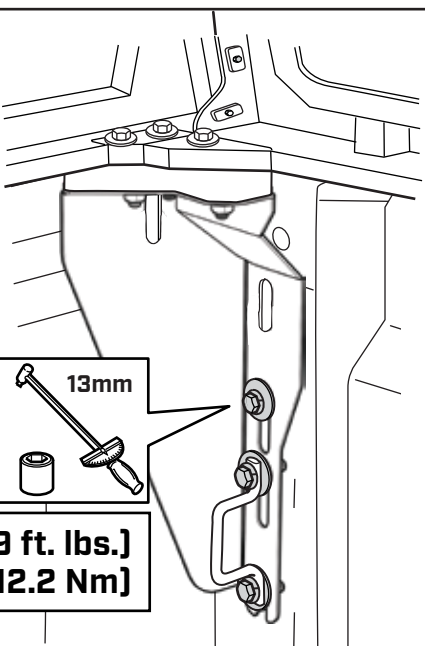

[9 ft. lbs.]  
[12.2 Nm]

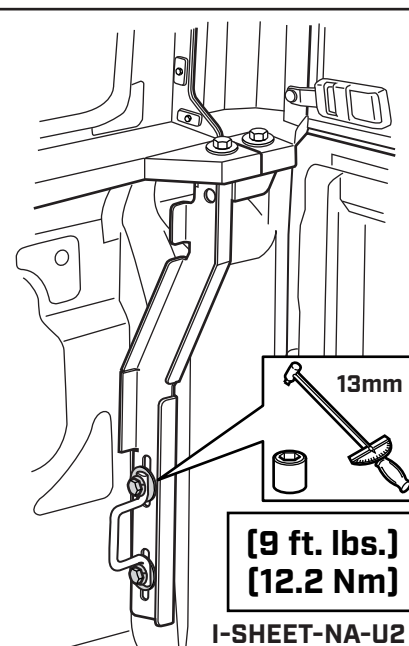

I-SHEET-NA-U2

## THIRD BRAKE LIGHT CONNECTOR INSTALLATION



### IMPORTANT

- ▼ BE SURE THE VEHICLE IS TURNED OFF FOR THIS INSTALLATION.
- ▼ READ THROUGH THE ENTIRE PROCEDURE BEFORE STARTING AND FOLLOW THE STEPS CAREFULLY TO ENSURE THE THIRD BRAKE LIGHT AND TRAILER PLUG WILL FUNCTION PROPERLY.
- ▼ USE A TEST LIGHT TO CHECK FOR SUCCESSFUL INSTALLATION.

▼ IF YOU DO NOT SEE YOUR MAKE/MODEL DETAILED BELOW PLEASE REACH OUT TO OUR SUPPORT TEAM FOR MORE INFORMATION AT [SUPPORT.NA@SMARTCAP.COM](mailto:SUPPORT.NA@SMARTCAP.COM)

## STEP 62-67

### WITH 7-WAY CONNECTOR

- GM COLORADO/CANYON (2015-2022)
- RAM 1500 & 2500/3500 (2019-2022)
- TOYOTA TUNDRA (2007-2021)

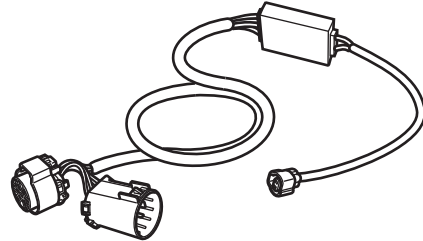

## STEP 68-73

### WITHOUT 7-WAY CONNECTOR

- GM SILVERADO/SIERRA 1500 (2019-2023)
- FORD F-150 (2015-2020)
- GM COLORADO (2023)

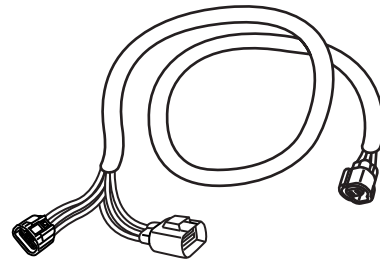

## STEP 74-85

- FORD RANGER (2019-2022)

### LED TAIL LIGHT HARNESS

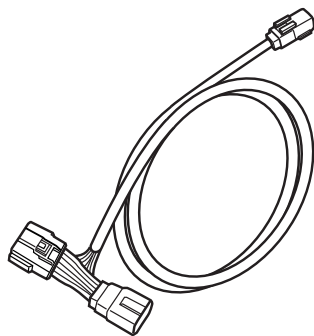

INCLUDED IN FITMENT KIT

### INCANDESCENT TAIL LIGHT HARNESS

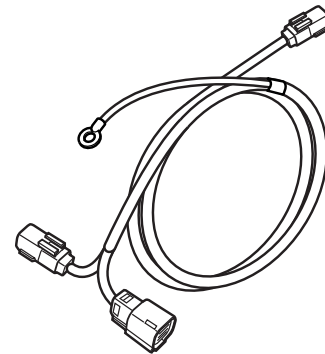

IF YOUR RANGER IS EQUIPPED WITH INCANDESCENT TAILLIGHTS, TO RECEIVE THE APPROPRIATE HARNESS, CONTACT [SUPPORT.NA@SMARTCAP.COM](mailto:SUPPORT.NA@SMARTCAP.COM)

## STEP 62

### WITH 7-WAY CONNECTOR

LOCATE THE 7-WAY TRAILER CONNECTOR AT THE HITCH OR INSIDE THE BUMPER.

DISCONNECT THE PLUG FROM THE BACK OF THE 7-WAY CONNECTOR.

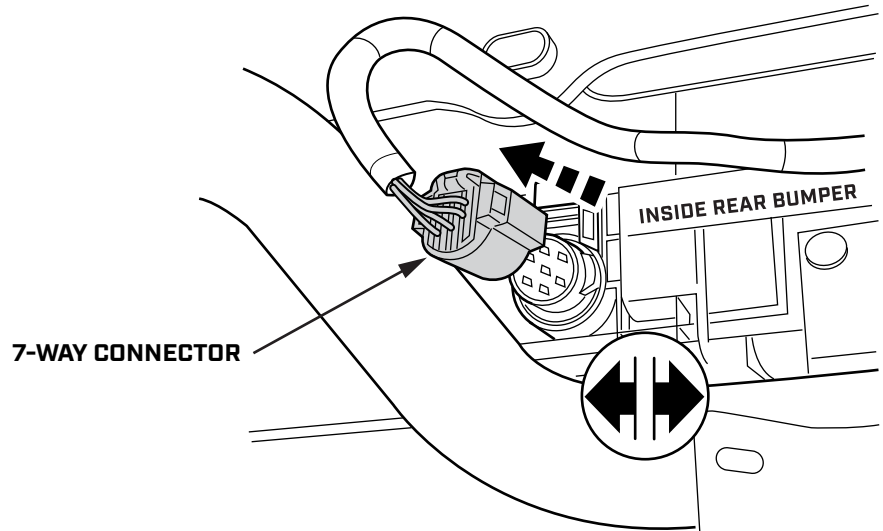

## STEP 63

### WITH 7-WAY CONNECTOR

PLUG THE NEW T-HARNESS INTO THE BACK OF THE 7-WAY CONNECTOR.

CONNECT THE ORIGINAL PLUG INTO THE FEMALE SIDE OF THE T-HARNESS.

BE SURE PLUGS ARE FULLY INSERTED AND LOCKING TABS ARE IN PLACE.

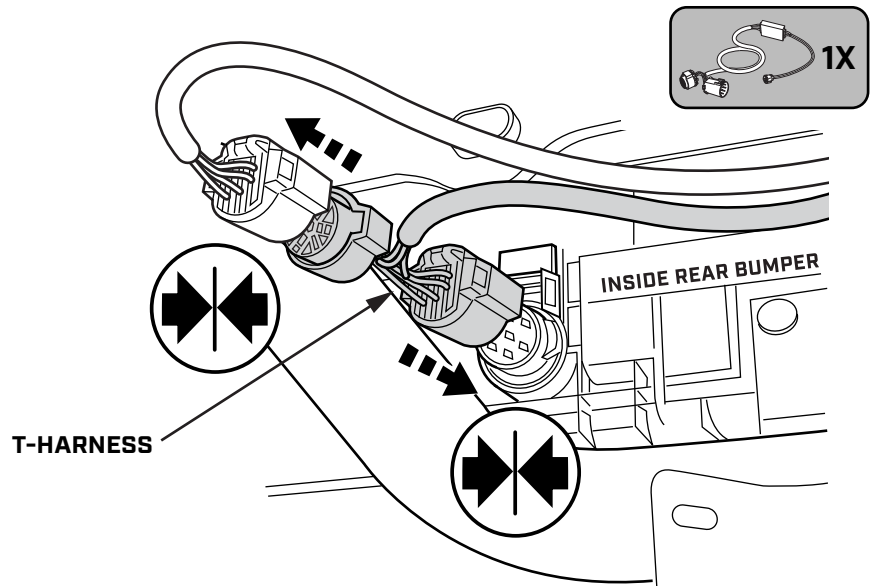

## STEP 64

### WITH 7-WAY CONNECTOR

UNTIE THE THIRD BRAKE LIGHT EXTENSION HARNESS FROM WHERE IT IS ATTACHED TO THE SMARTCAP AT THE RIGHT LEFT CORNER.

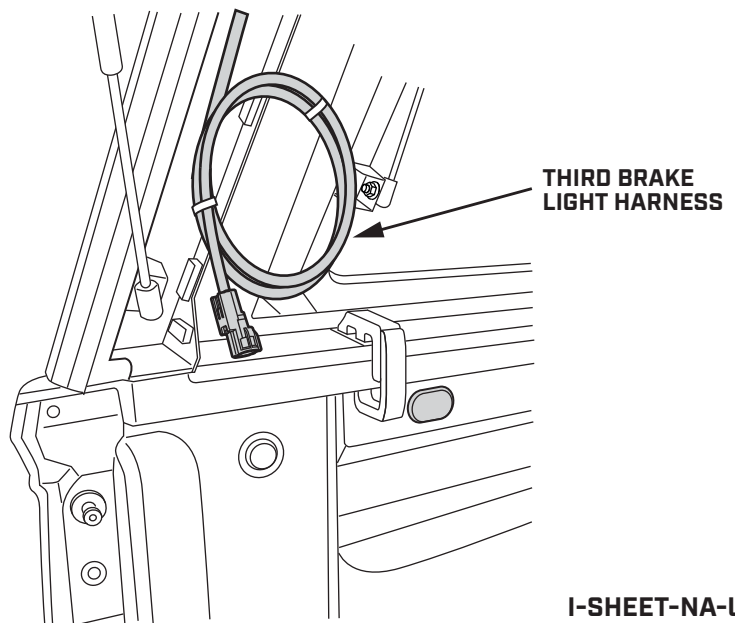

I-SHEET-NA-U2

## STEP 65

### WITH 7-WAY CONNECTOR

REMOVE THE GROMMET COVER AT THE TRUCK BED WALL.

ROUTE THE THIRD BRAKE LIGHT HARNESS IN THROUGH THE GROMMET OPENING AND DOWN TOWARDS THE REAR BUMPER..

THIRD BRAKE LIGHT HARNESS

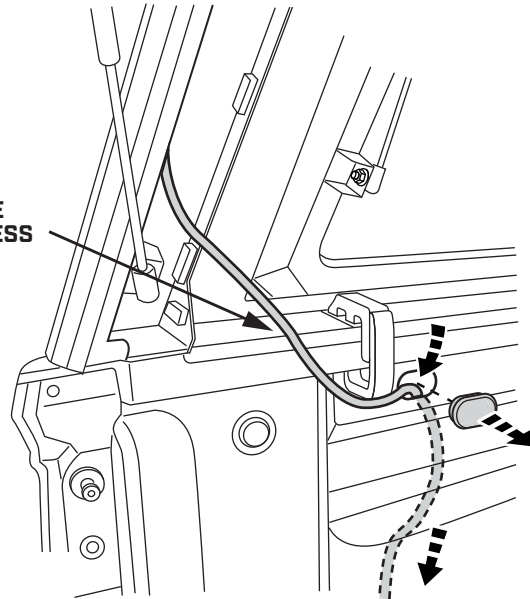

## STEP 66

### WITH 7-WAY CONNECTOR

ROUTE THE T-HARNESS ALONG THE INSIDE OF THE REAR BUMPER WITH THE 2-PIN PLUG GOING UP TOWARDS THE DRIVER SIDE TAILLIGHT.

CONNECT THE 2-PIN FEMALE PLUG OF THE T-HARNESS INTO THE MALE 2-PIN PLUG OF THE THIRD BRAKE LIGHT HARNESS.

THIRD BRAKE LIGHT HARNESS

T-HARNESS

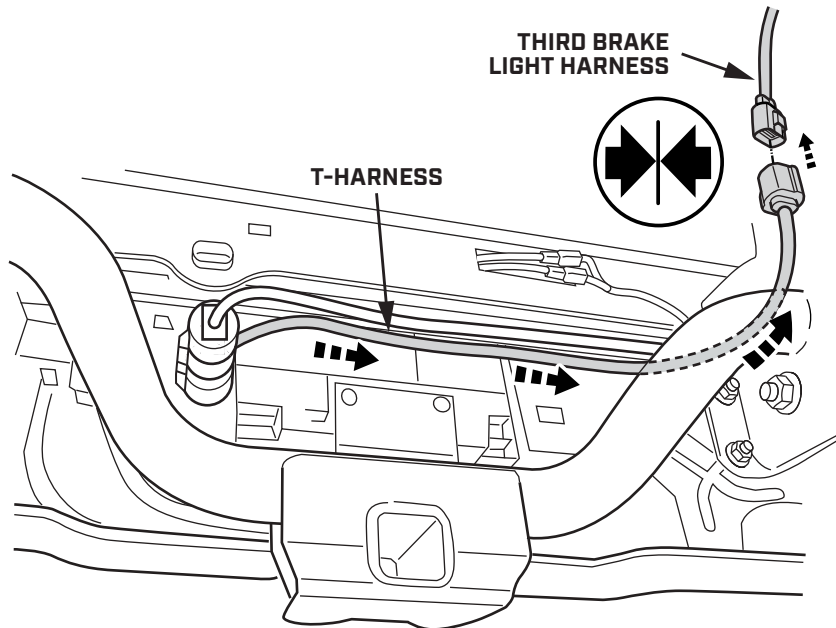

## STEP 67



### TEST YOUR BRAKE LIGHTS & TURN SIGNALS

- ▼ START THE TRUCK. SOME MODELS MAY TAKE UP TO 30 SECONDS FOR THE VEHICLE TO DETECT THE NEW CONNECTION.
- ▼ CHECK THE BRAKE LIGHTS AND TURN SIGNALS TO BE SURE THEY ARE FUNCTIONING PROPERLY.
- ▼ ONCE YOU HAVE CONFIRMED THAT THE LIGHTS ARE WORKING CORRECTLY, SECURE THE HARNESS WITH CABLE TIES.
- ▼ BE SURE NOT TO INTERFERE WITH ANY MOVING PARTS ON THE VEHICLE.
- ▼ YOUR CAP INSTALLATION IS COMPLETE. YOU CAN FIND SMARTCAP CONTACT INFORMATION ON PAGE 39.



## STEP 68

### WITHOUT 7-WAY CONNECTOR

UNTIE THE THIRD BRAKE LIGHT EXTENSION HARNESS FROM WHERE IT IS ATTACHED TO THE SMARTCAP AT THE LEFT REAR CORNER.

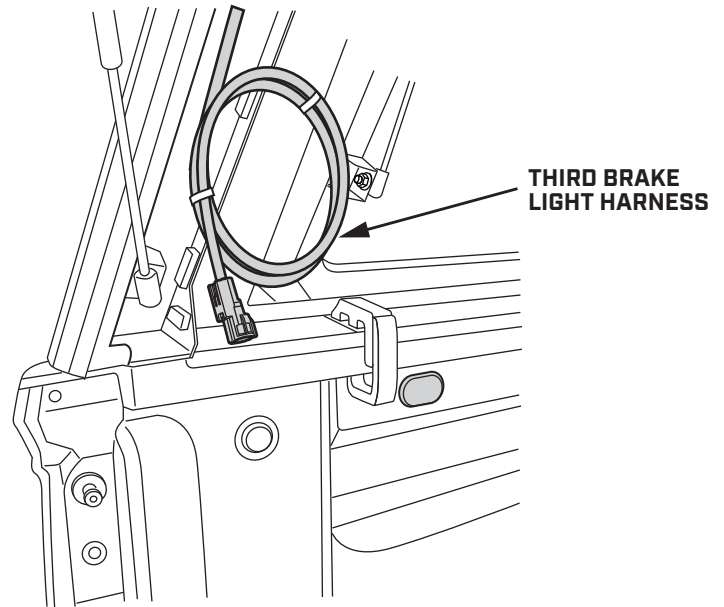

## STEP 69

### WITHOUT 7-WAY CONNECTOR

REMOVE THE GROMMET COVER AT THE TRUCK BED WALL.

ROUTE THE THIRD BRAKE LIGHT HARNESS IN THROUGH THE GROMMET OPENING AND DOWN TOWARDS THE REAR BUMPER.

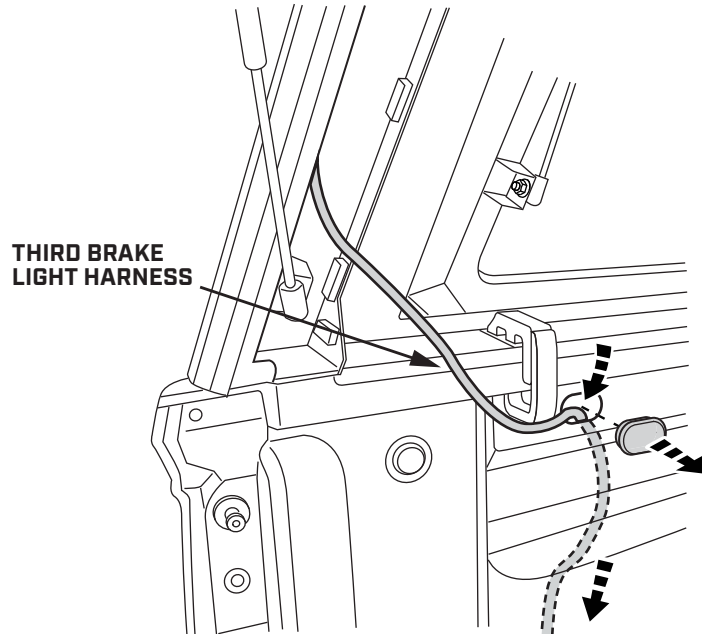

## STEP 70

### WITHOUT 7-WAY CONNECTOR

CONNECT THE T-HARNESS TO THE 2-PIN CONNECTOR AT THE END OF THE BRAKE LIGHT EXTENSION HARNESS.

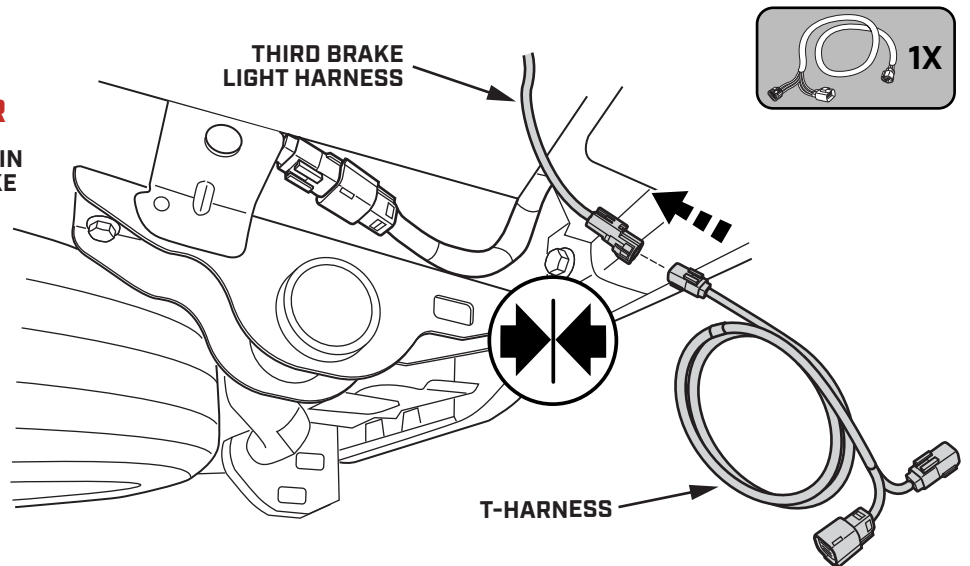

I-SHEET-NA-U2

## STEP 71

### WITHOUT 7-WAY CONNECTOR

LOCATE THE 4-PIN OR 6-PIN CONNECTOR ON THE SIDE OF THE LEFT CHASSIS RAIL AND DISCONNECT IT.

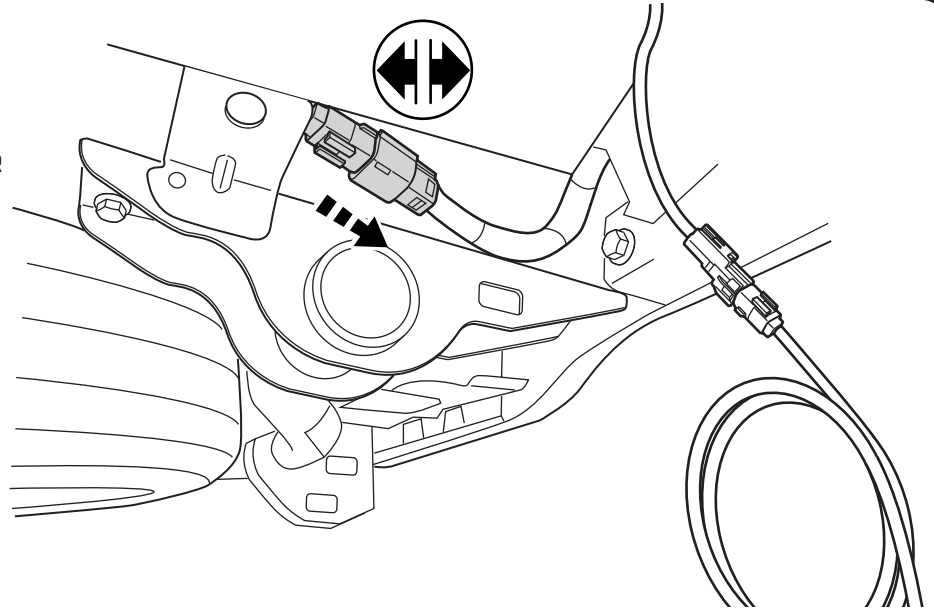

## STEP 72

### WITHOUT 7-WAY CONNECTOR

CONNECT THE T-HARNESS FEMALE CONNECTOR TO THE VEHICLE HARNESS MALE CONNECTOR.

CONNECT THE T-HARNESS MALE CONNECTOR TO THE VEHICLE HARNESS FEMALE CONNECTOR.

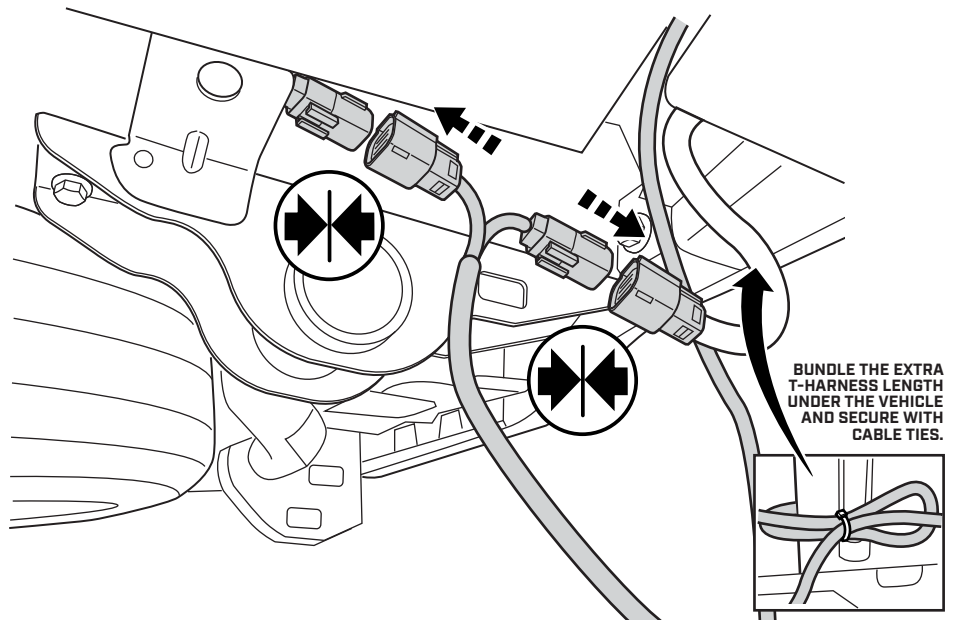

## STEP 73



### TEST YOUR BRAKE LIGHTS & TURN SIGNALS

- ▼ START THE TRUCK. SOME MODELS MAY TAKE UP TO 30 SECONDS FOR THE VEHICLE TO DETECT THE NEW CONNECTION.
- ▼ CHECK THE BRAKE LIGHTS AND TURN SIGNALS TO BE SURE THEY ARE FUNCTIONING PROPERLY.
- ▼ ONCE YOU HAVE CONFIRMED THAT THE LIGHTS ARE WORKING CORRECTLY, SECURE THE HARNESS WITH CABLE TIES.
- ▼ BE SURE NOT TO INTERFERE WITH ANY MOVING PARTS ON THE VEHICLE.
- ▼ YOUR CAP INSTALLATION IS COMPLETE. YOU CAN FIND SMARTCAP CONTACT INFORMATION ON PAGE 39.

# STEP 74

## FORD RANGER

UNTIE THE THIRD BRAKE LIGHT EXTENSION HARNESS FROM WHERE IT IS ATTACHED TO THE SMARTCAP AT THE RIGHT REAR CORNER.

NOTE: THE CONNECTOR ON THE END OF THE HARNESS WILL NEED TO BE DE-PINNED IN ORDER TO ROUTE THROUGH THIS HOLE.

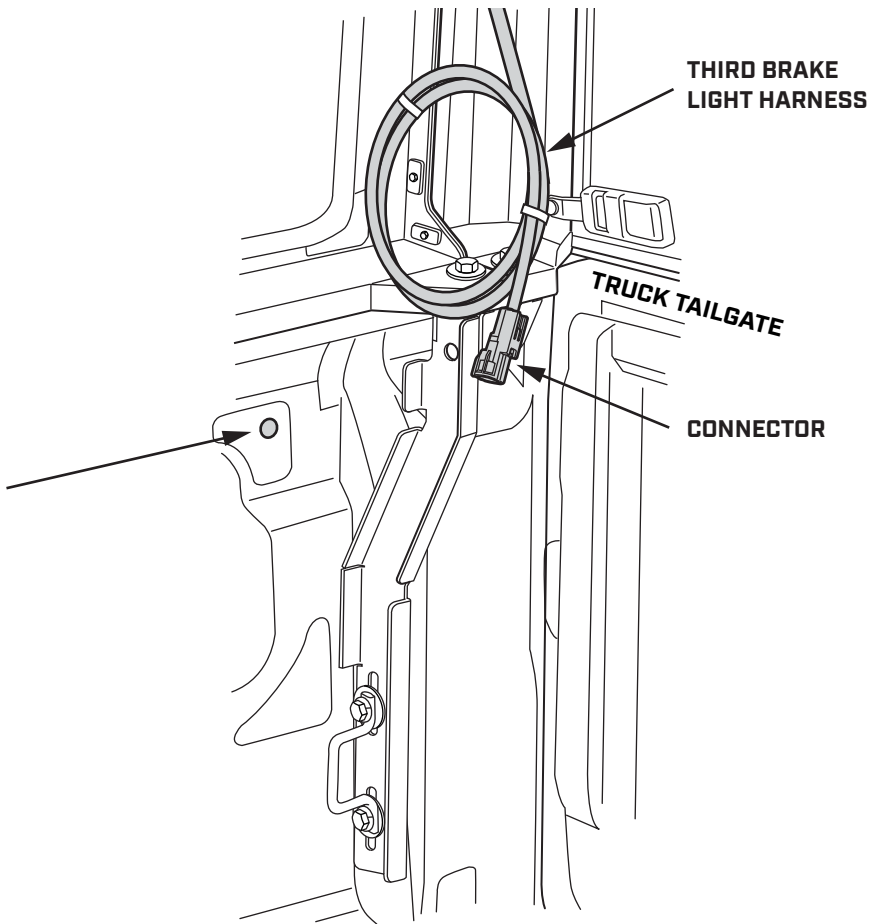

# STEP 75

## FORD RANGER

DE-PIN CONNECTOR.

 TAKE NOTE OF WIRE ORIENTATION

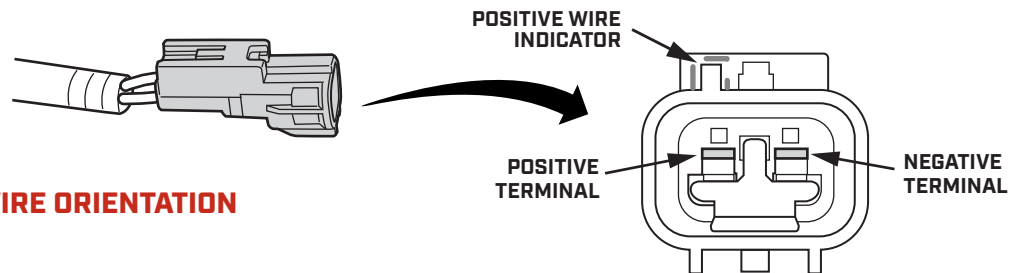

**A** USE A SCREWDRIVER TO PULL THE LOCK CLIP FORWARD.

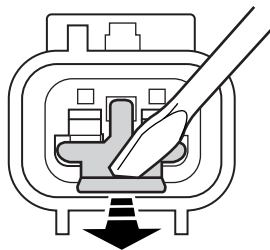

**B** USE A PIN TOOL TO PRESS DOWN ON THE WIRE RELEASE TABS.

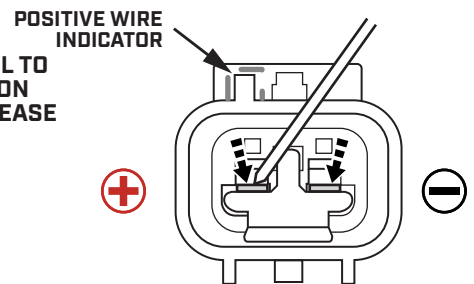

**C** WHILE PRESSING DOWN ON THE RELEASE TABS, REMOVE EACH OF THE WIRES FROM THE CONNECTOR.

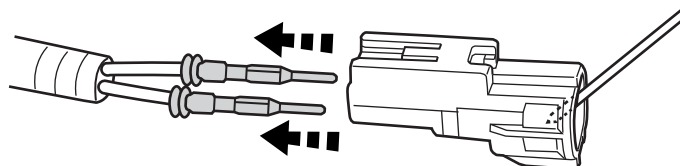

I-SHEET-NA-U2

# STEP 76

## FORD RANGER

ROUTE THE THIRD BRAKE LIGHT EXTENSION HARNESS THROUGH THE HOLE AND DOWN TOWARDS THE INSIDE REAR BUMPER.



**BE SURE NOT TO DAMAGE TERMINALS**

THIRD BRAKE LIGHT HARNESS

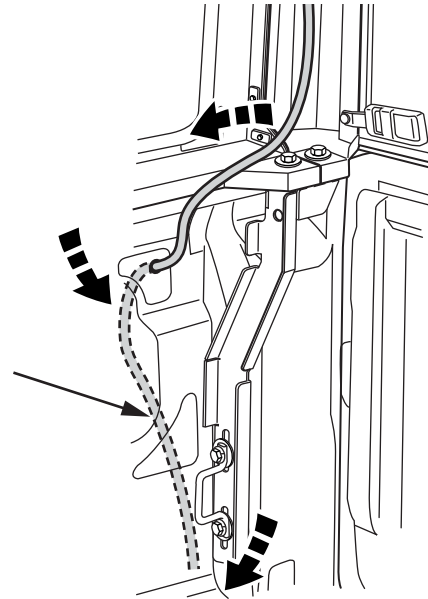

# STEP 77

## FORD RANGER

RE-ATTACH THE CONNECTOR TO THE THIRD BRAKE LIGHT HARNESS IN THE SAME FASHION AS IT WAS REMOVED.

SEE STEP 75

POSITIVE WIRE INDICATOR

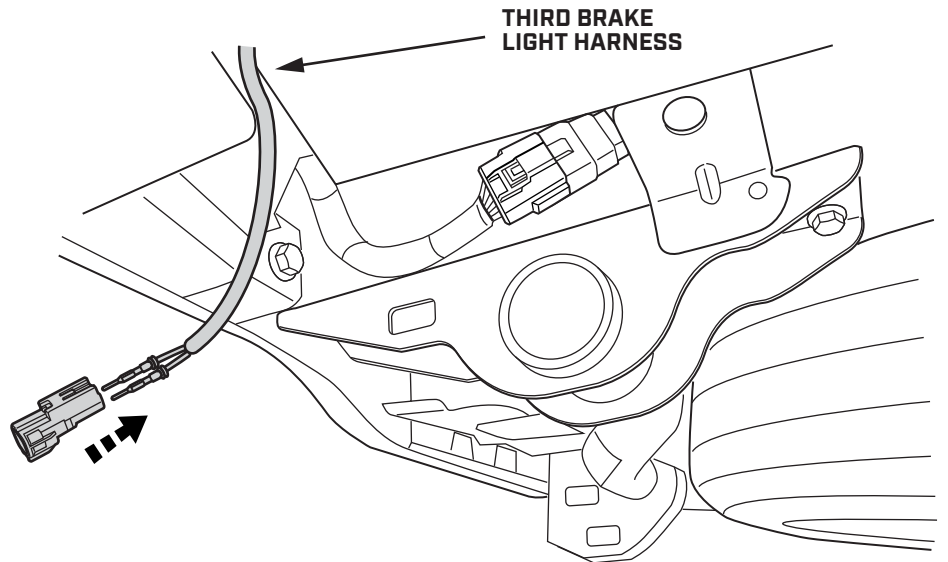
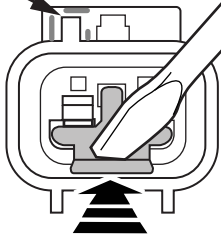

# STEP 78

## FORD RANGER WITH LED TAILLIGHTS

CONNECT THE LED T-HARNESS TO THE 2-PIN CONNECTOR AT THE END OF THE BRAKE LIGHT EXTENSION HARNESS.

LED T-HARNESS

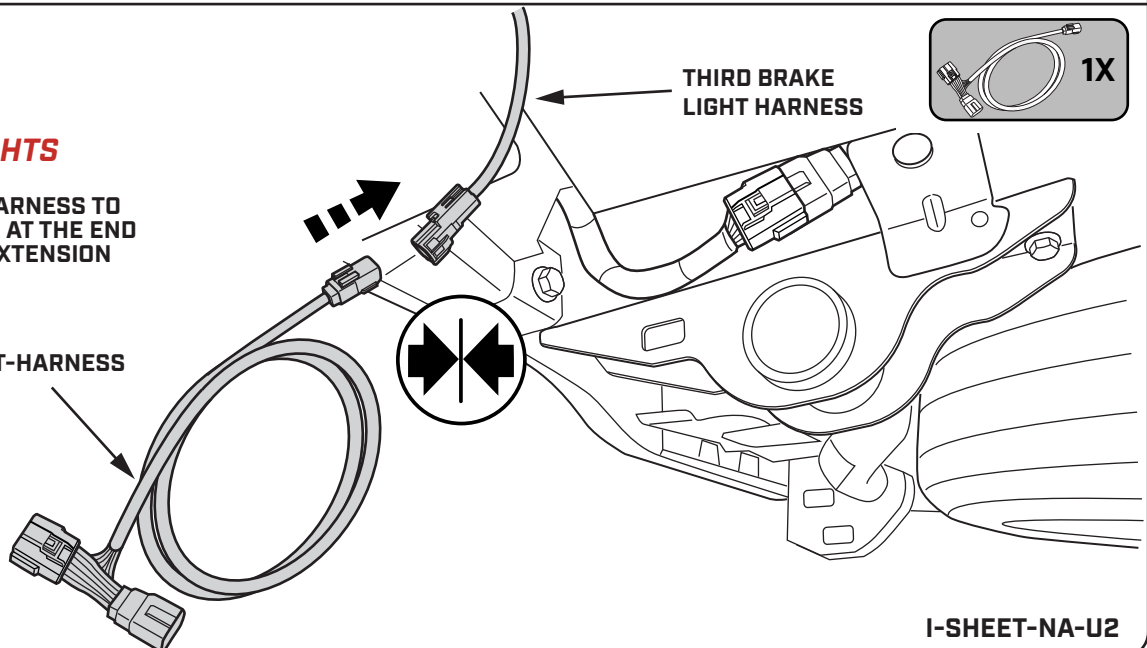

I-SHEET-NA-U2

## STEP 79

### FORD RANGER WITH LED TAILLIGHTS

LOCATE THE 16-PIN CONNECTOR ON THE SIDE OF THE PASSENGER CHASSIS RAIL AND DISCONNECT IT.

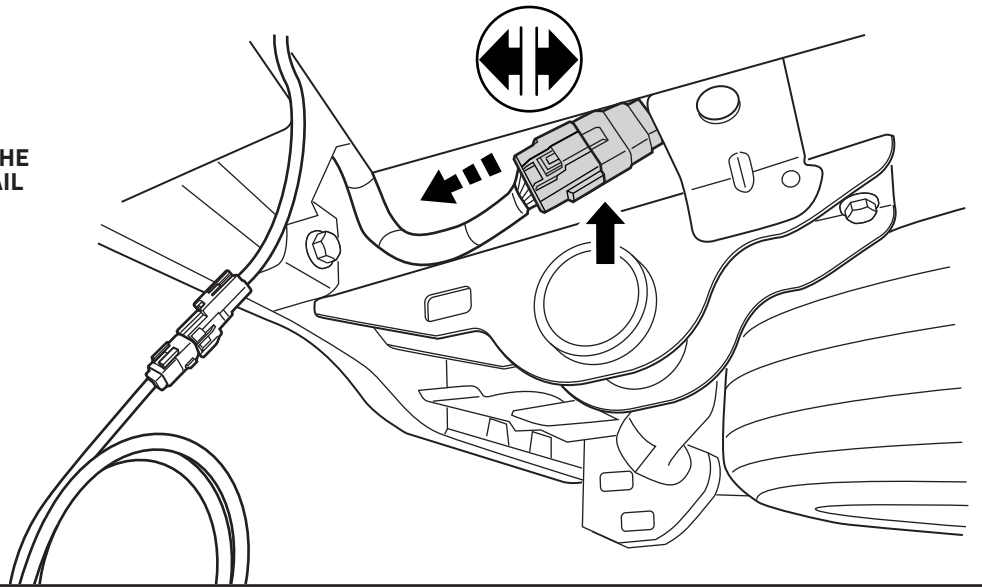

## STEP 80

### FORD RANGER WITH LED TAILLIGHTS

CONNECT THE T-HARNESS FEMALE CONNECTOR TO THE VEHICLE HARNESS MALE CONNECTOR.

CONNECT THE T-HARNESS MALE CONNECTOR TO THE VEHICLE HARNESS FEMALE CONNECTOR.

BUNDLE THE EXTRA T-HARNESS LENGTH UNDER THE VEHICLE AND SECURE WITH CABLE TIES

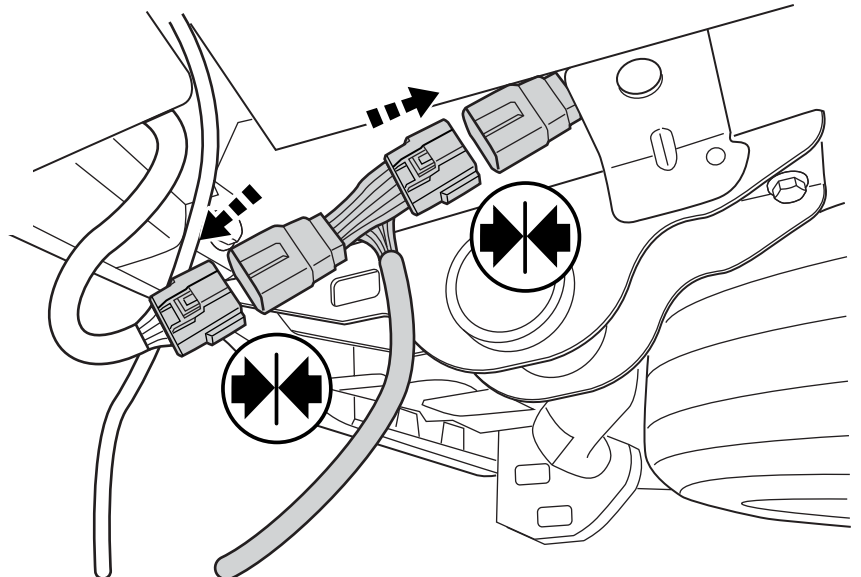
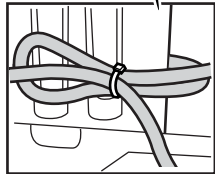

## STEP 81

### FORD RANGER INCANDESCENT TAILLIGHTS

CONNECT THE INCANDESCENT T-HARNESS TO THE 2-PIN CONNECTOR AT THE END OF THE BRAKE LIGHT EXTENSION HARNESS.

INCANDESCENT T-HARNESS

THIRD BRAKE LIGHT HARNESS

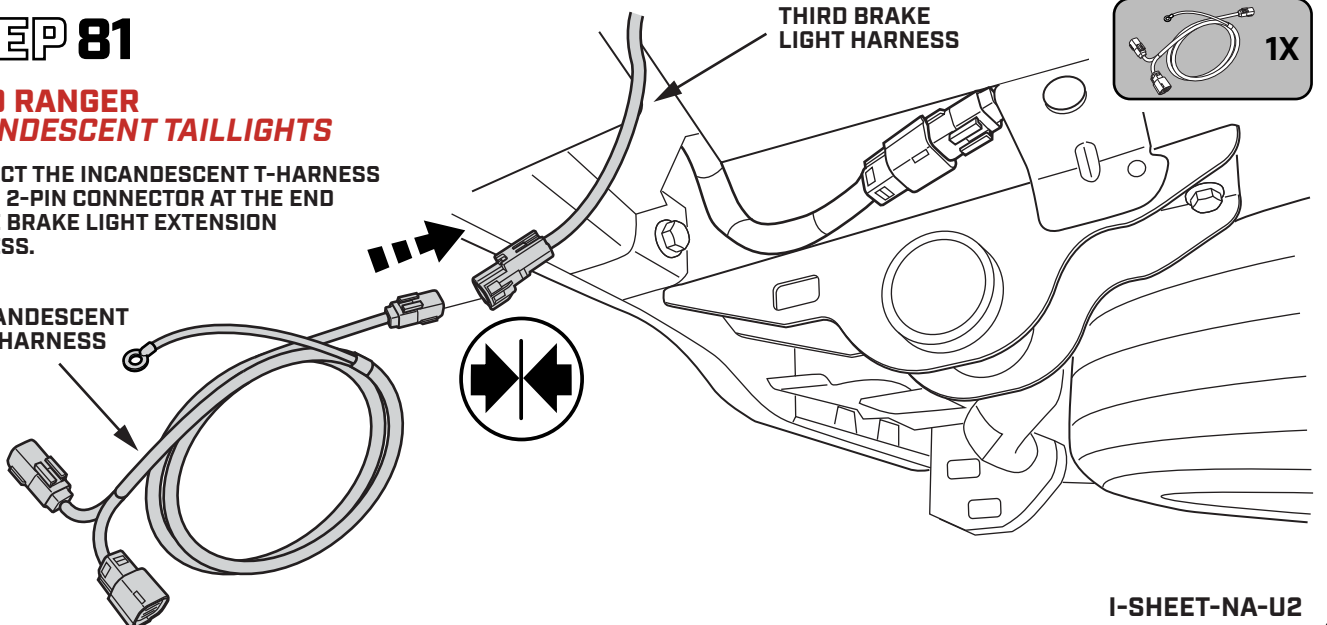
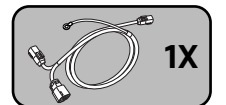

I-SHEET-NA-U2

## STEP 82

### FORD RANGER INCANDESCENT TAILLIGHTS

LOCATE THE 6-PIN CONNECTOR ON THE SIDE OF THE PASSENGER CHASSIS RAIL AND DISCONNECT IT.

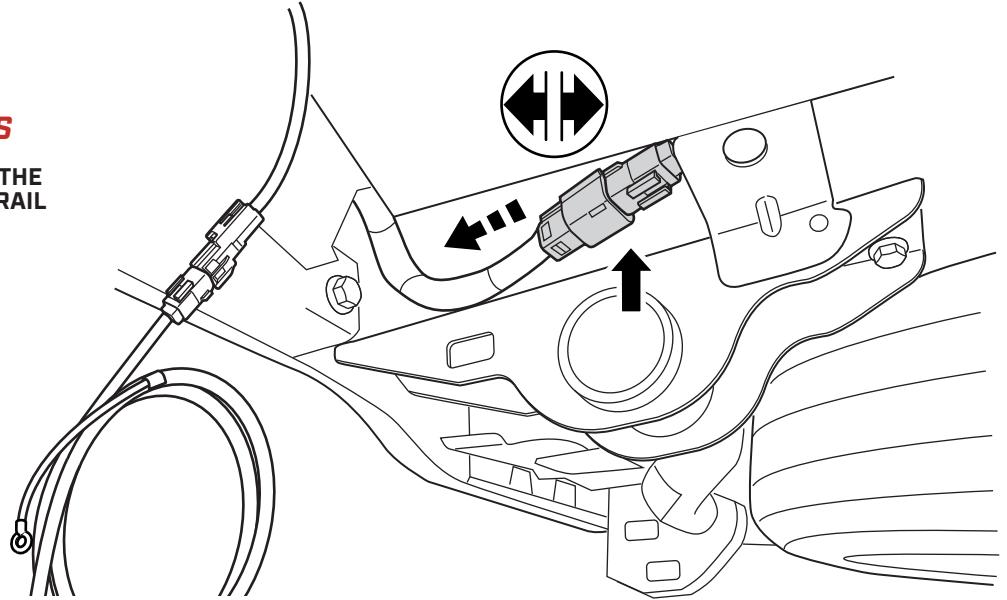

## STEP 83

### FORD RANGER INCANDESCENT TAILLIGHTS

CONNECT THE T-HARNESS FEMALE CONNECTOR TO THE VEHICLE HARNESS MALE CONNECTOR.

CONNECT THE T-HARNESS MALE CONNECTOR TO THE VEHICLE HARNESS FEMALE CONNECTOR.

BUNDLE THE EXTRA T-HARNESS LENGTH UNDER THE VEHICLE AND SECURE WITH CABLE TIES

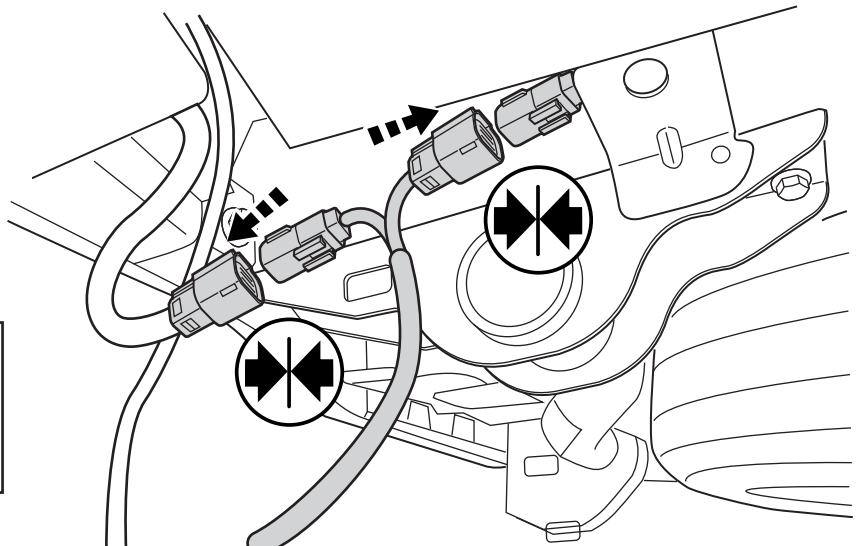
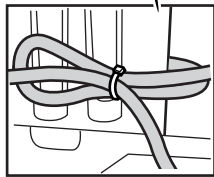

## STEP 84

### FORD RANGER INCANDESCENT TAILLIGHTS

SECURE THE GROUND WIRE ON THE T-HARNESS TO THE CHASSIS AT A SUITABLE LOCATION UNDER THE VEHICLE.

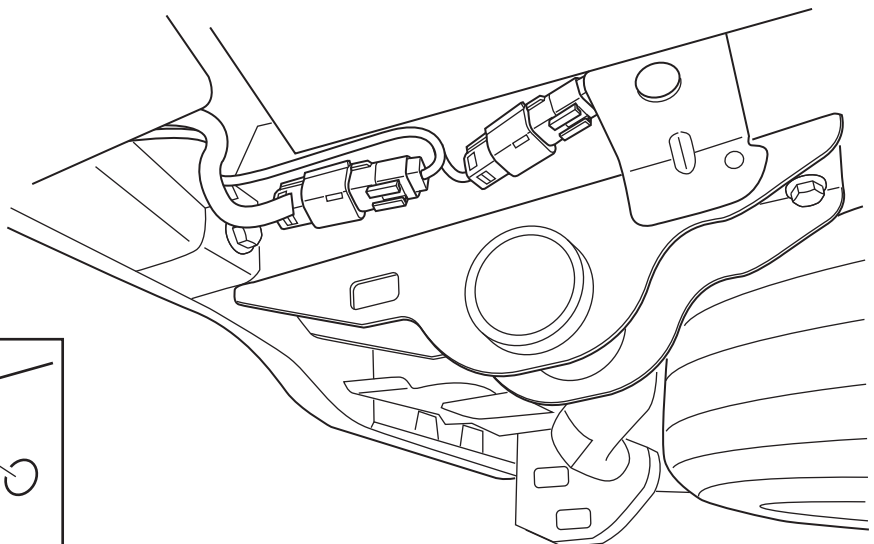
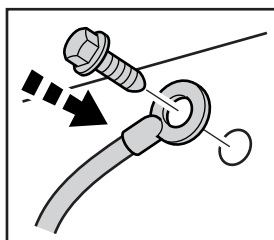

I-SHEET-NA-U2

## STEP 85



### TEST YOUR BRAKE LIGHTS & TURN SIGNALS

- ▼ START THE TRUCK. SOME MODELS MAY TAKE UP TO 30 SECONDS FOR THE VEHICLE TO DETECT THE NEW CONNECTION.
- ▼ CHECK THE BRAKE LIGHTS AND TURN SIGNALS TO BE SURE THEY ARE FUNCTIONING PROPERLY.
- ▼ ONCE YOU HAVE CONFIRMED THAT THE LIGHTS ARE WORKING CORRECTLY, SECURE THE HARNESS WITH CABLE TIES.
- ▼ BE SURE NOT TO INTERFERE WITH ANY MOVING PARTS ON THE VEHICLE.



THANKS FOR YOUR PURCHASE.

PLEASE LET US KNOW IF YOU HAVE ANY QUESTIONS.

**SMARTCAP.COM - SUPPORT.NA@SMARTCAP.COM - NORTH AMERICA**

