

SMARTCAP®

INSTRUCTION GUIDE

TOYOTA TACOMA

2024-CURRENT (4th Generation)

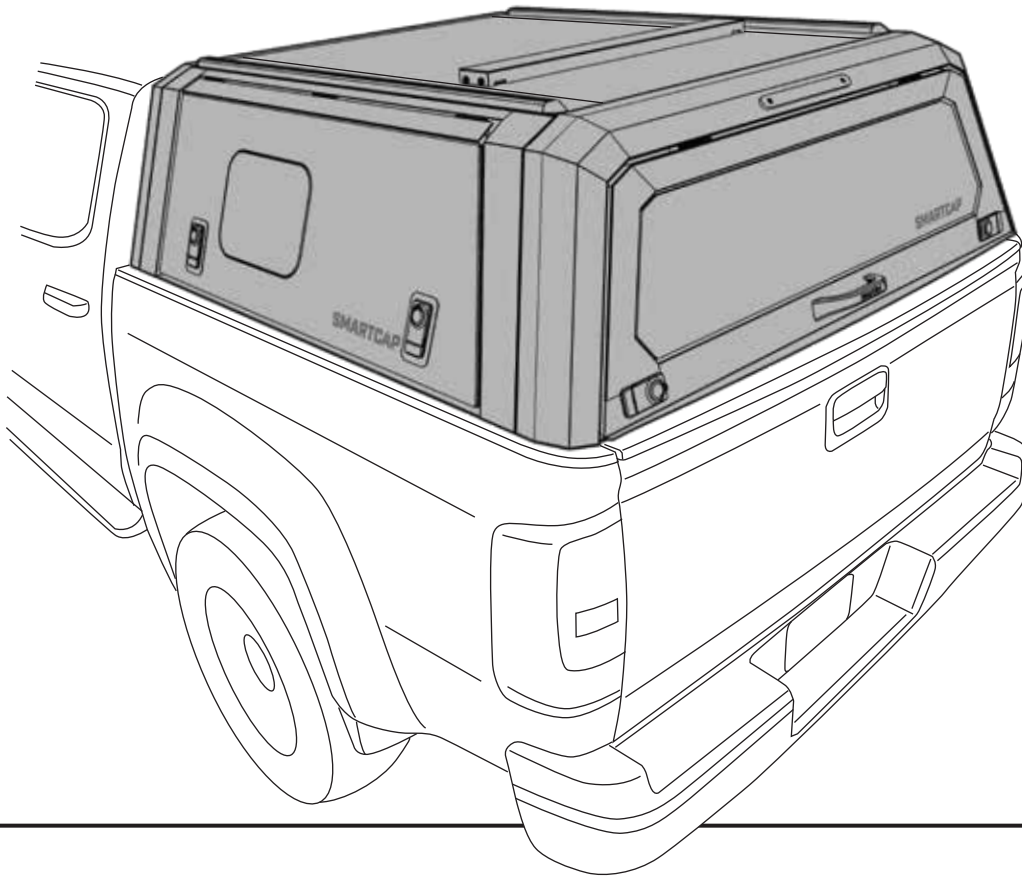

- ▼ **PREPARE A CLEAN WORK AREA.**
- ▼ **WE RECOMMEND A MINIMUM OF 2 PEOPLE FOR ASSEMBLY AND 4 PEOPLE FOR INSTALLATION.**
- ▼ **ENSURE THE REQUIRED TOOLS ARE PRESENT AND ALL HARDWARE CONTENTS ARE ACCOUNTED FOR.**
- ▼ **NEVER USE ACETONE OR THINNERS ON PAINTED PARTS.**
- ▼ **READ THROUGH THE ENTIRE INSTRUCTION GUIDE BEFORE STARTING THIS PROCEDURE AND FOLLOW THE STEPS CAREFULLY TO AVOID ANY DAMAGE TO THE COMPONENTS OR THE VEHICLE.**

SMARTCAP.COM

SUPPORT.NA@SMARTCAP.COM - NORTH AMERICA

SUPPORT.SA@SMARTCAP.COM - REST OF WORLD



I-SHEET-NA-TA3

TOOLS REQUIRED



IMPORTANT

- ▼ USE ONLY THE TOOLS RECOMMENDED ABOVE.
- ▼ USE ONLY THE HARDWARE PROVIDED IN THIS KIT.
- ▼ ASSISTANCE WILL BE NEEDED FOR THIS INSTALLATION.
FOUR PEOPLE ARE RECOMMENDED TO LIFT THE SMARTCAP ONTO THE VEHICLE.
- ▼ AVOID PINCHING OR CRUSHING HANDS AND FINGERS.
- ▼ INSPECT ALL KIT COMPONENTS FOR DAMAGE BEFORE ASSEMBLY.
- ▼ NEVER USE ACETONE OR THINNERS ON PAINTED PARTS.

COMPONENTS

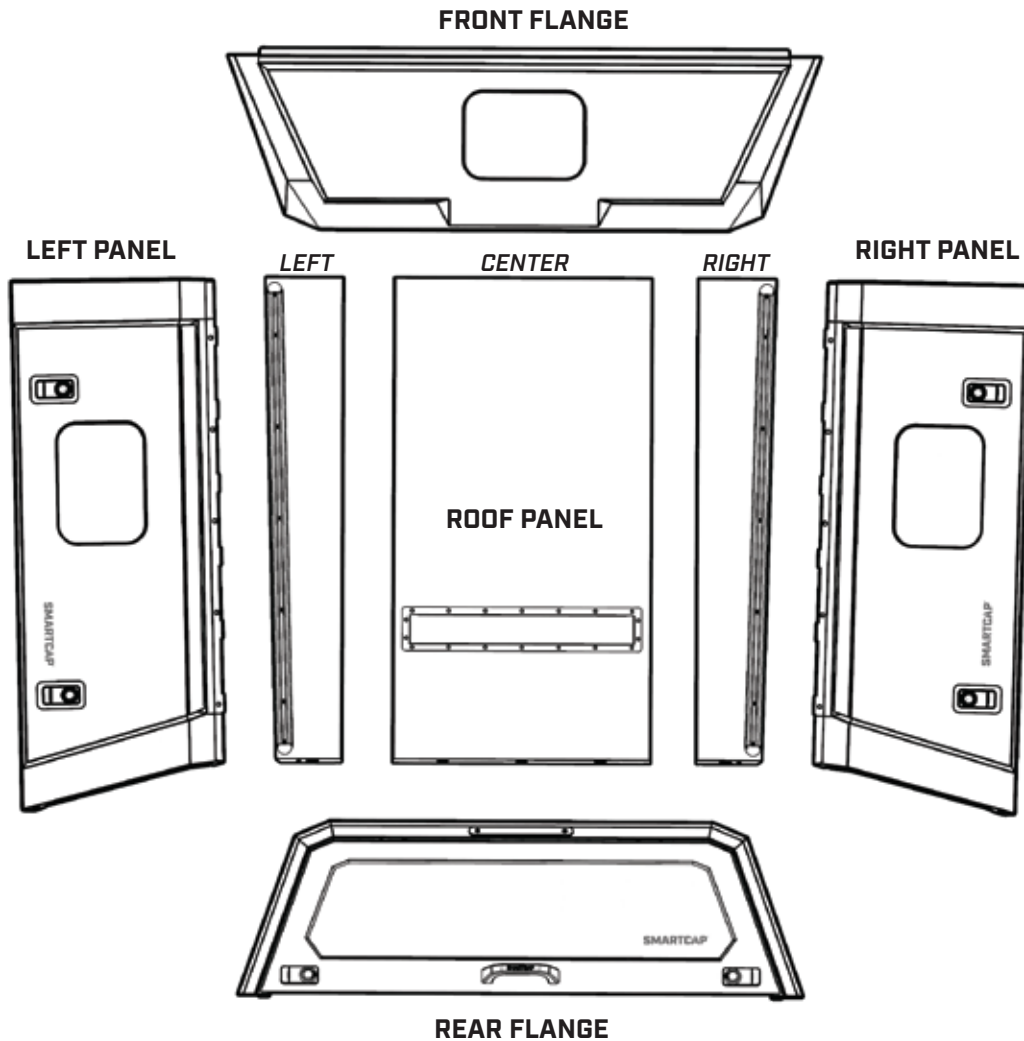

I-SHEET-NA-TA3

ASSEMBLY HARDWARE

FITMENT KIT

M6 BOLT

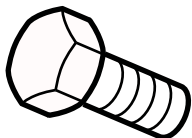

40X

**FASTENER
BLOCK CLAMP**

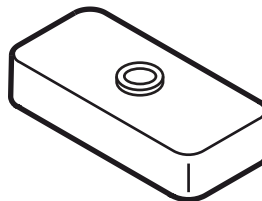

40X

**M6 LOCK
WASHER**



40X

**FASTENER
BLOCK**

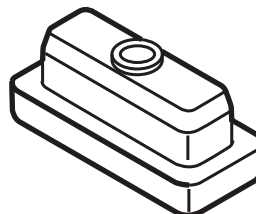

40X

D - RUBBER



1X

SPARE PARTS

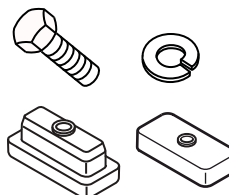

2X

PRE-FASTENED TO ROOF PANEL

**M6 FENDER
WASHER**



10X

SHORT BED

12X

STANDARD BED

**M6 LOCK
NUT**

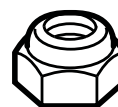

10X

SHORT BED

12X

STANDARD BED

STEP 1



IMPORTANT

- ▼ BE SURE TO REMOVE ALL SEVEN PANELS FROM THEIR PACKAGING AND INSPECT THE PAINTED SURFACES PRIOR TO ASSEMBLY, AS SMARTCAP WILL NOT ACCEPT WARRANTY CLAIMS AFTER ASSEMBLY IS COMPLETED. IF MANUFACTURING IMPERFECTIONS OR SHIPPING DAMAGES ARE FOUND, DO NOT CONTINUE WITH THE ASSEMBLY PROCESS AND CONTACT SUPPORT.NA@SMARTCAP.COM.

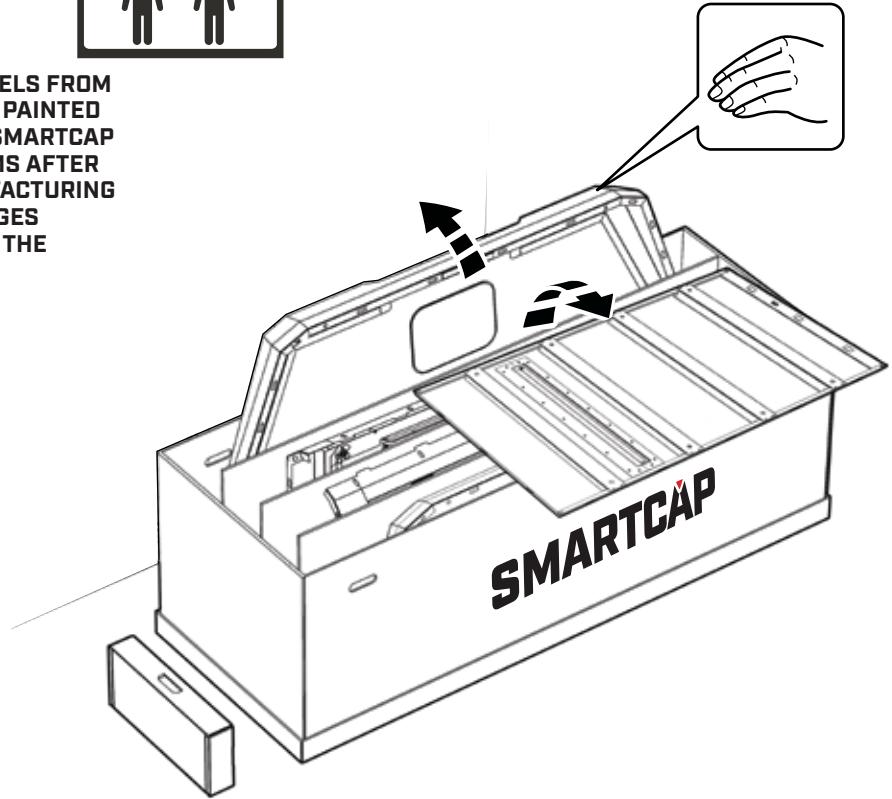

STEP 2

REMOVE THE FOUR CORNER STIFFENERS AND ONE OF THE CARDBOARD DIVIDERS TO BE USED AS A PROTECTIVE SURFACE DURING ASSEMBLY.

UNFOLD THE CARDBOARD DIVIDER AND PLACE IT WHERE YOU PLAN TO ASSEMBLE YOUR CAP.

PLACE THE FOUR CORNER STIFFENERS AS SHOWN BELOW.

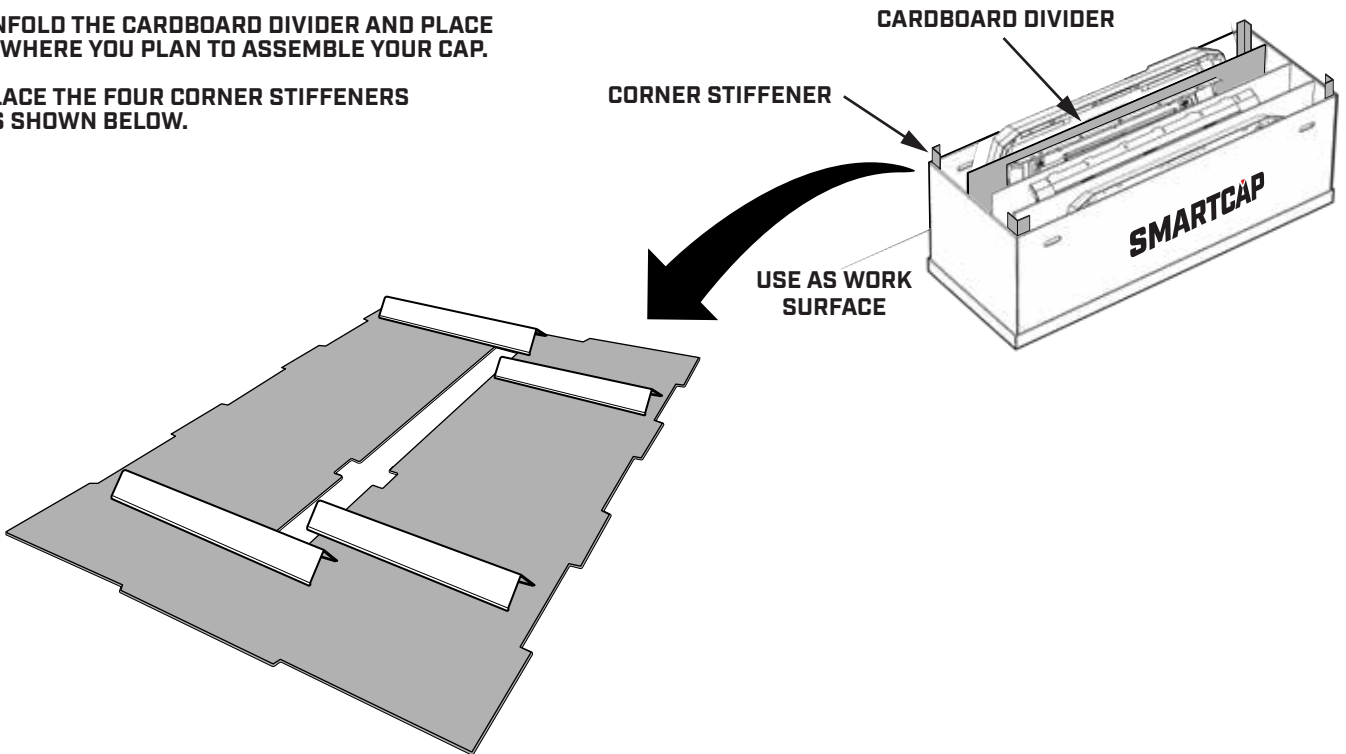

I-SHEET-NA-TA3

STEP 3

PLACE THE ROOF PANELS ON TOP OF THE CORNER STIFFENERS, WITH THE BOTTOM OF THE ROOF PANELS FACING UP.

ALIGN THE PANELS SO THAT THE PROFILE OF THE FRONT AND REAR EDGES MATCH.

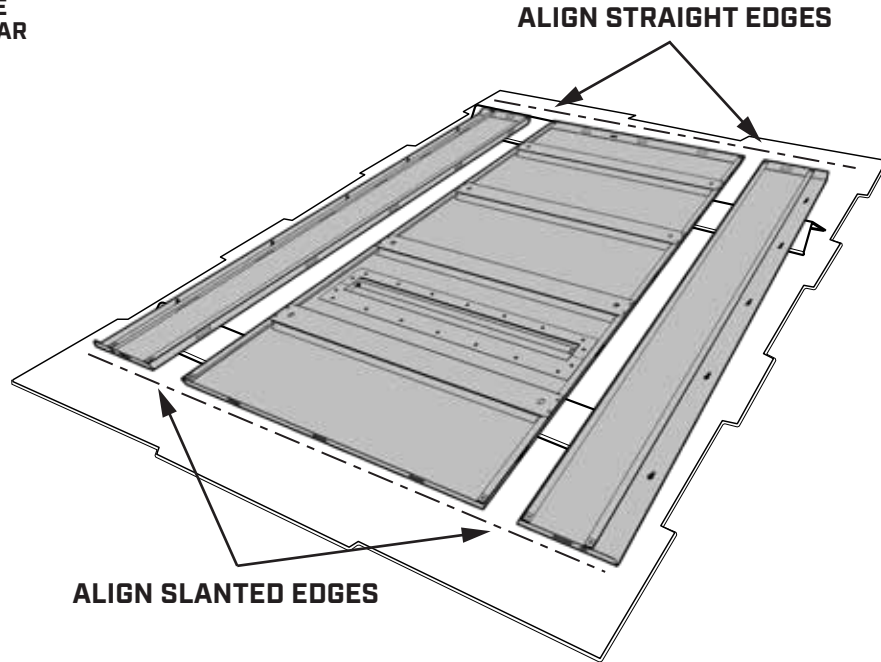

STEP 4

ASSEMBLE THE FASTENER BLOCKS TO THE ROOF PANELS USING A TORQUE WRENCH AND 10MM SOCKET TO 3.7 FT. LBS [5 NEWTON METERS].

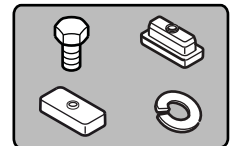

MAKE SURE ROOF PANELS ARE LEVEL

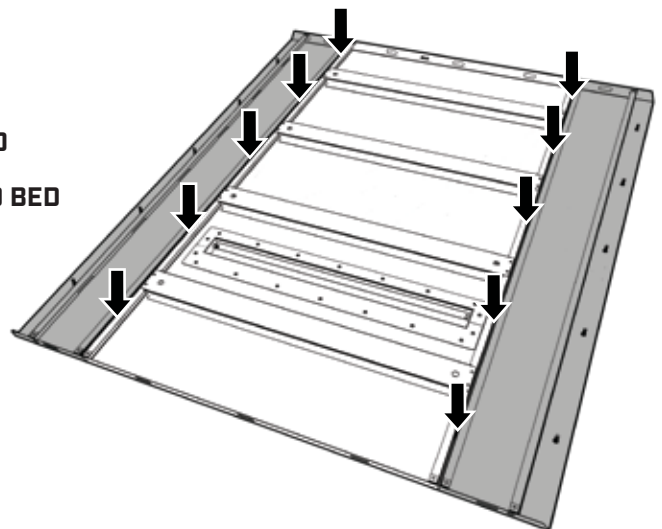
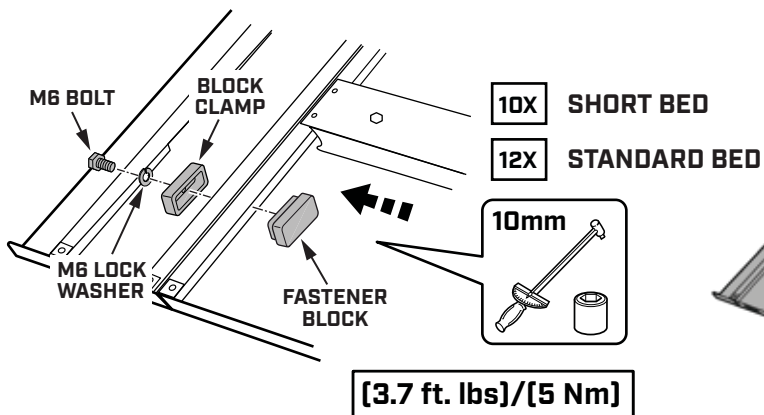

I-SHEET-NA-TA3

STEP 5

USE A 10MM COMBINATION WRENCH TO REMOVE THE LOCK NUTS AND FENDER WASHERS FROM THE ROOF BOLTS AND SAVE FOR REUSE.



AIR VENT INDICATES REAR

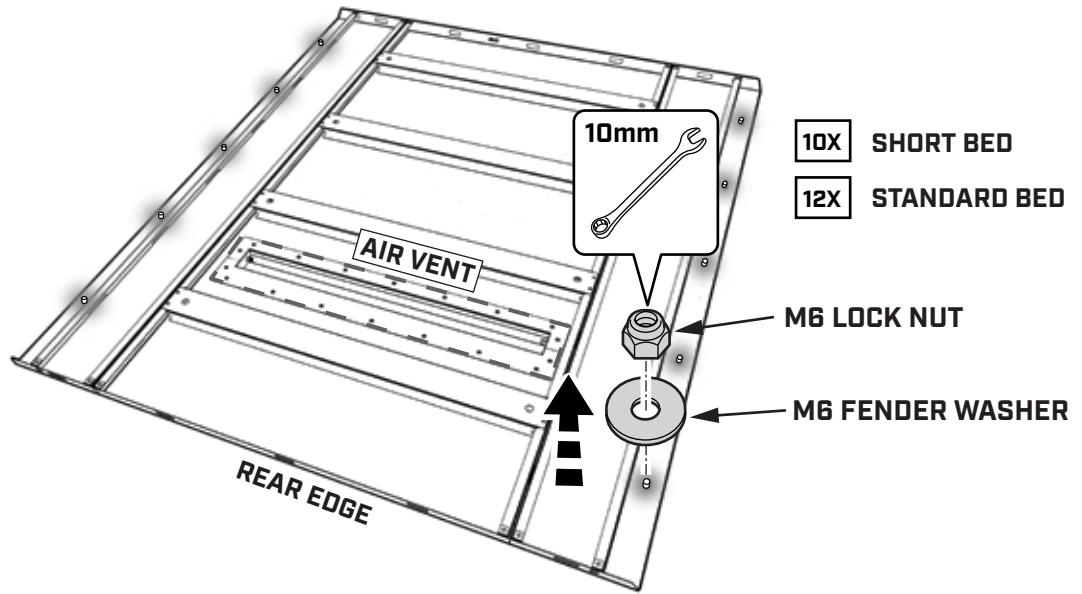

STEP 6

RETRIEVE THE FASTENER BLOCKS FROM THE FITMENT KIT AND PLACE 15 ON EACH SIDE OF THE ROOF PANEL.

TAKE APART THE FASTENER BLOCKS SO THEY ARE READY TO USE DURING ASSEMBLY.

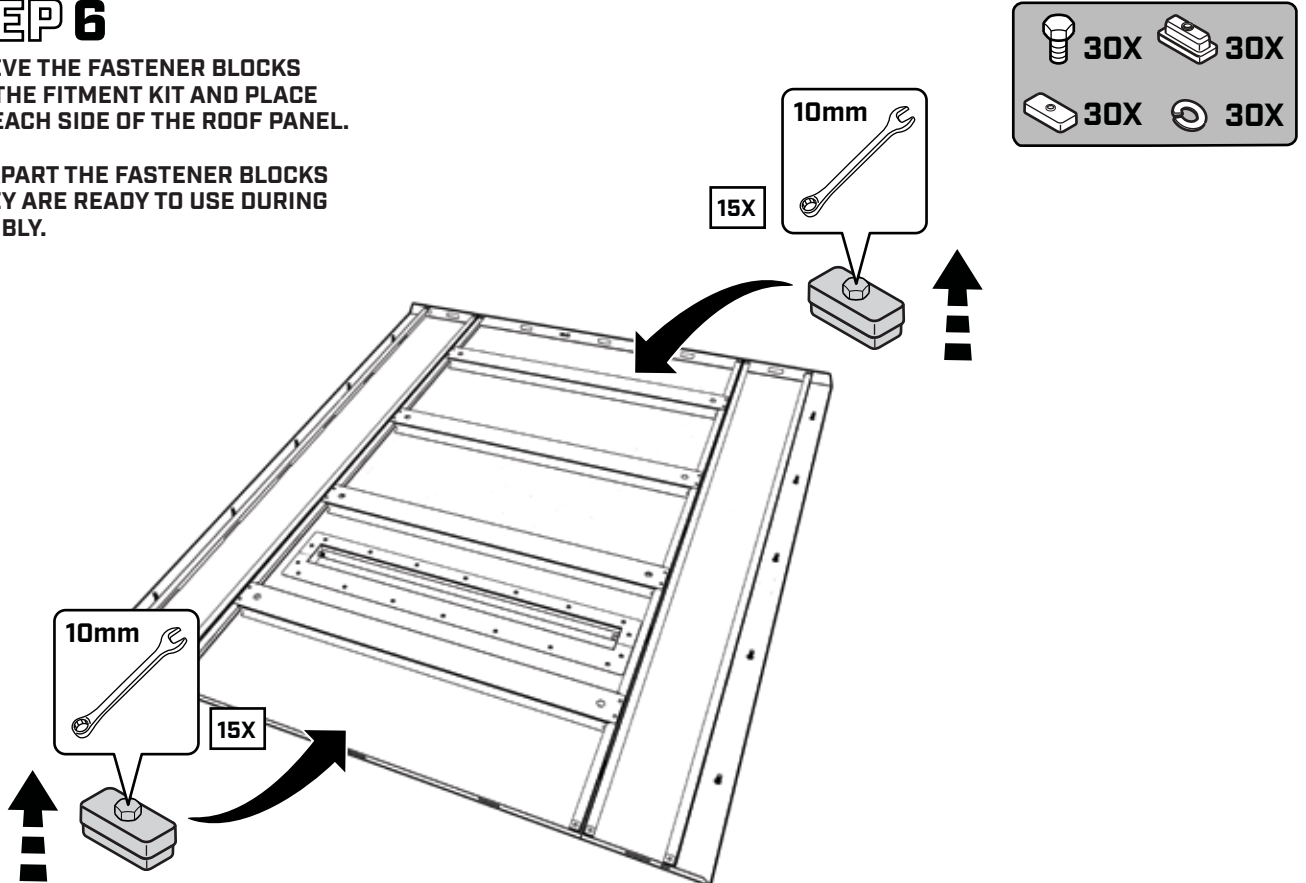

STEP 7

LOCATE THE RIGHT PANEL IN THE SMARTCAP PACKAGE AND BRING IT TO YOUR WORK AREA.



SLANTED EDGE INDICATES REAR

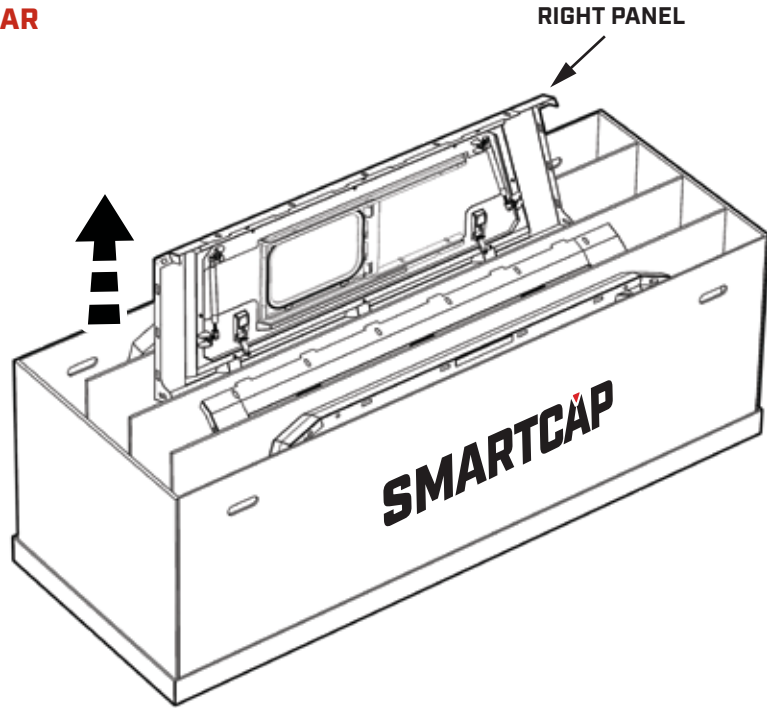

STEP 8

INSERT PANEL TABS INTO THE NARROW SLOTS JUST ABOVE FOAM PADDING ON ROOF PANEL.

TAP FIRMLY WITH PALM OF HAND UNTIL THERE IS A 2-3MM GAP.

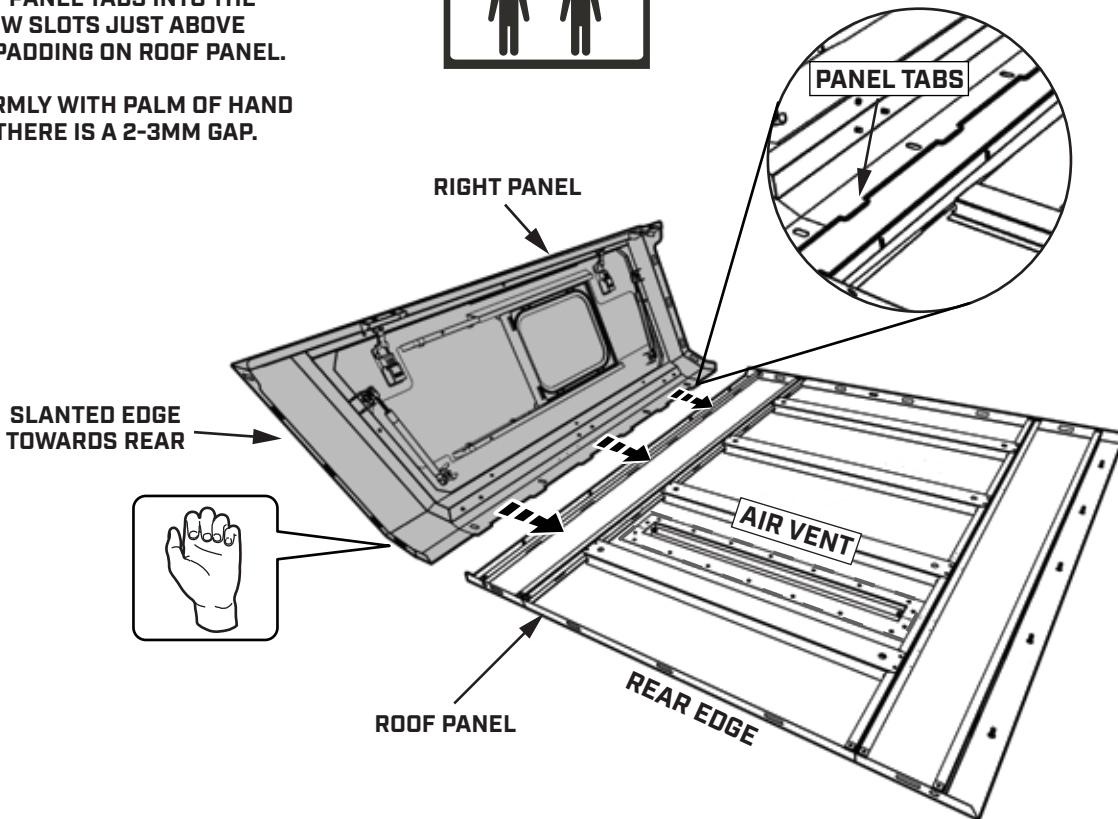

I-SHEET-NA-TA3

STEP 9

HAND TIGHTEN M6 LOCK NUT WITH M6 FENDER WASHER TO ALL BOLTS.

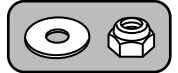

SUPPORT RIGHT PANEL UNTIL ASSEMBLED TO FRONT FLANGE

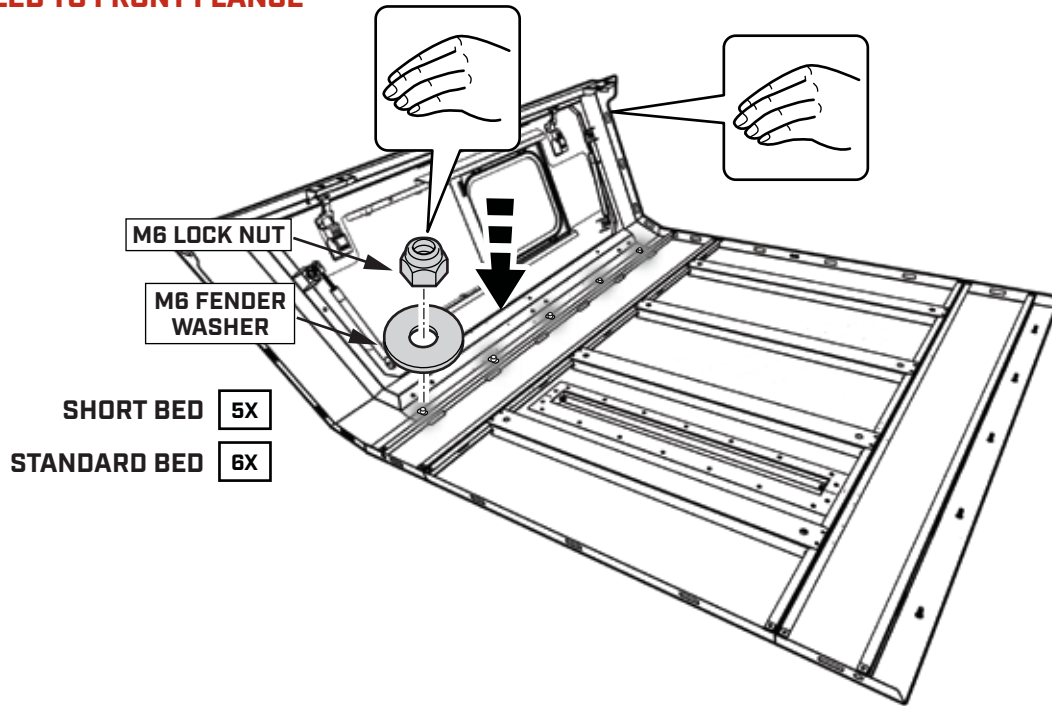

STEP 10

LOCATE THE FRONT FLANGE IN THE SMARTCAP PACKAGE AND BRING IT TO YOUR WORK AREA.

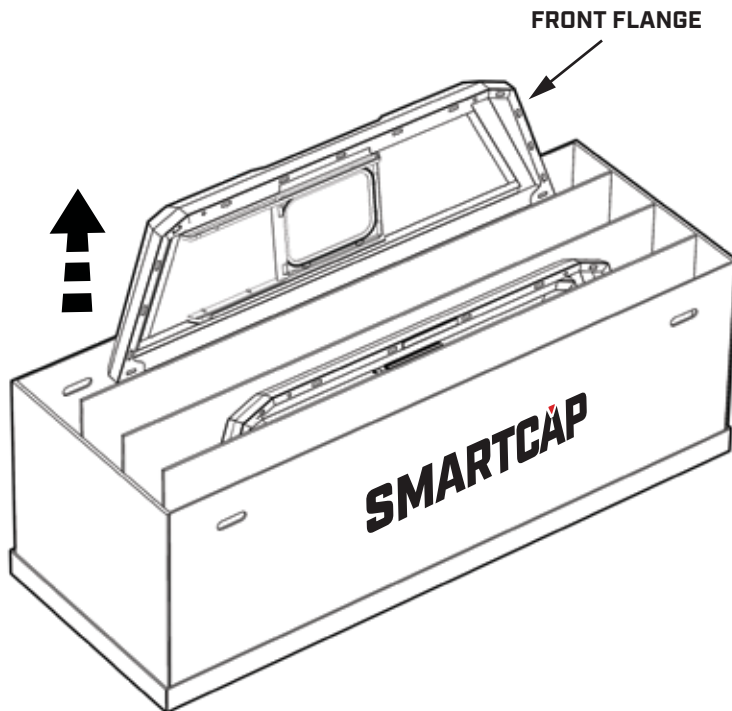

I-SHEET-NA-TA3

STEP 11

PLACE FRONT FLANGE AS SHOWN BELOW.

HAND TIGHTEN TWO FASTENER BLOCKS AT THE INDICATED LOCATIONS TO SUPPORT THE RIGHT PANEL AND FRONT FLANGE.

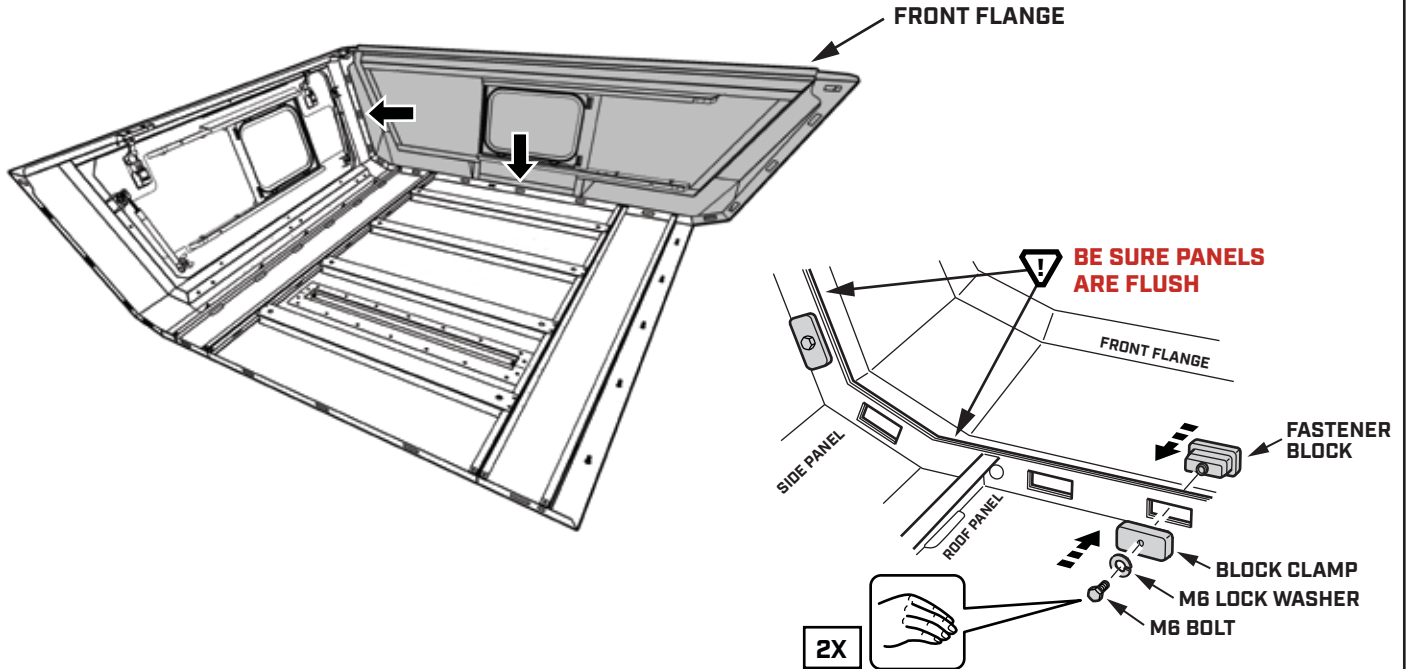

STEP 12

LOCATE THE LEFT PANEL IN THE SMARTCAP PACKAGE AND BRING IT TO YOUR WORK AREA.



SLANTED EDGE INDICATES REAR

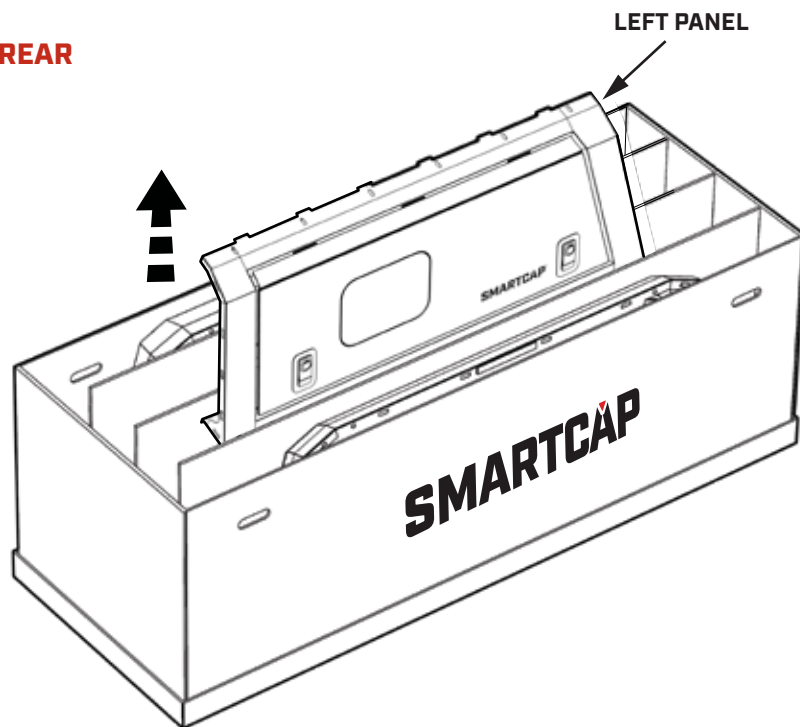

STEP 13

INSERT PANEL TABS INTO THE NARROW SLOTS JUST ABOVE FOAM PADDING ON ROOF PANEL.

TAP FIRMLY WITH PALM OF HAND UNTIL THERE IS A 2-3MM GAP.

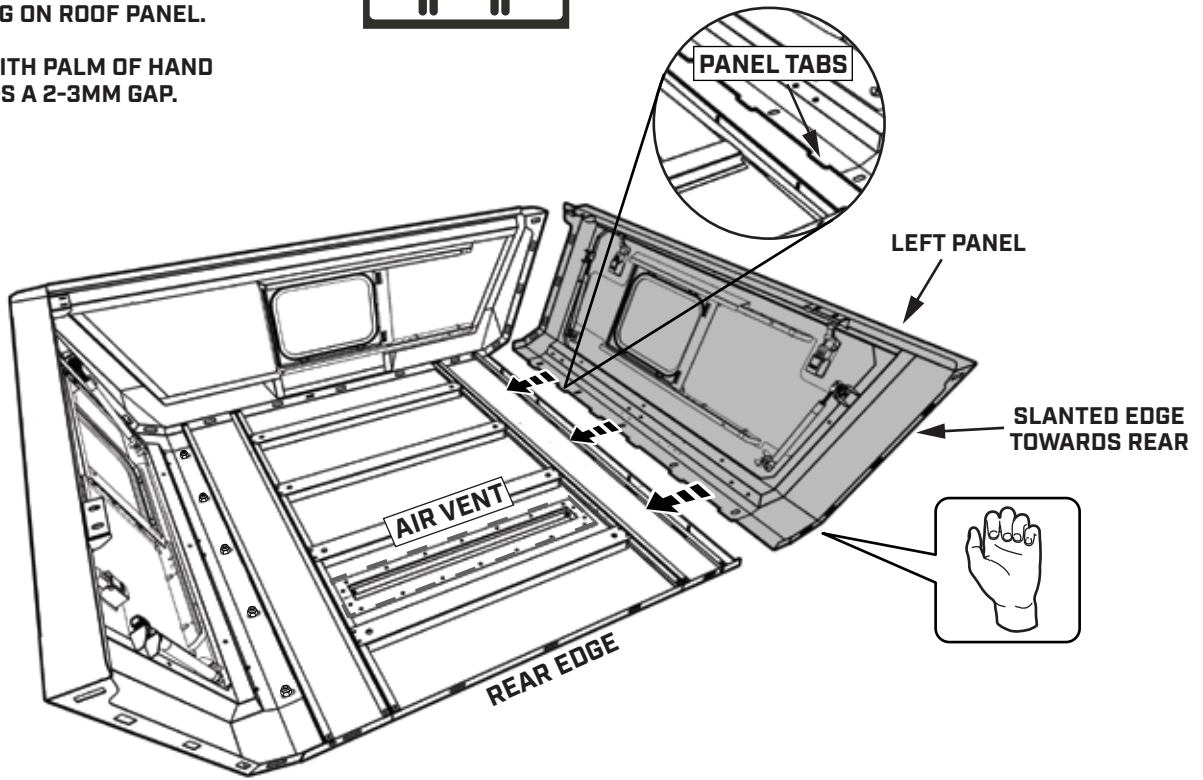

STEP 14

HAND TIGHTEN M6 LOCK NUT WITH M6 FENDER WASHER TO ALL BOLTS.

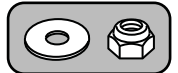

! SUPPORT LEFT PANEL UNTIL ASSEMBLED TO FRONT FLANGE

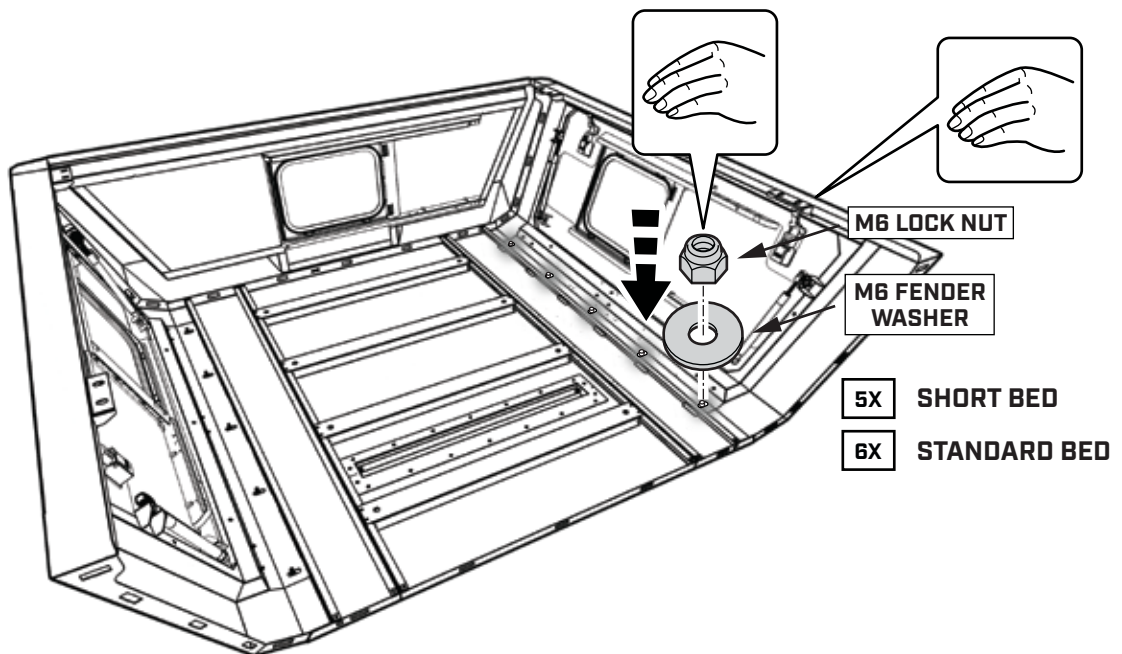

I-SHEET-NA-TA3

STEP 15

INSTALL HARDWARE ALONG FRONT FLANGE WITH BOLT ON INSIDE.

START AT CENTER OF THE FRONT FLANGE AND WORK YOUR WAY OUTWARDS.

ADJUST LEFT AND RIGHT PANELS TO ALIGN THE FASTENER BLOCK HOLES.

HAND TIGHTEN ONLY.

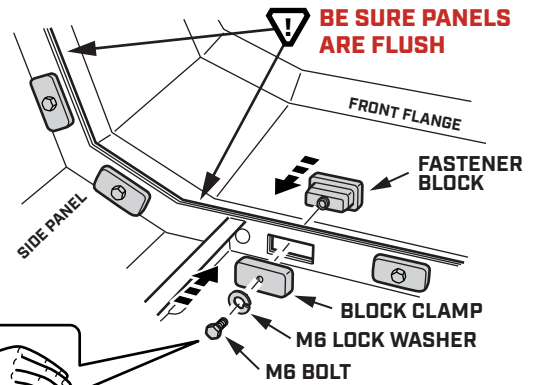
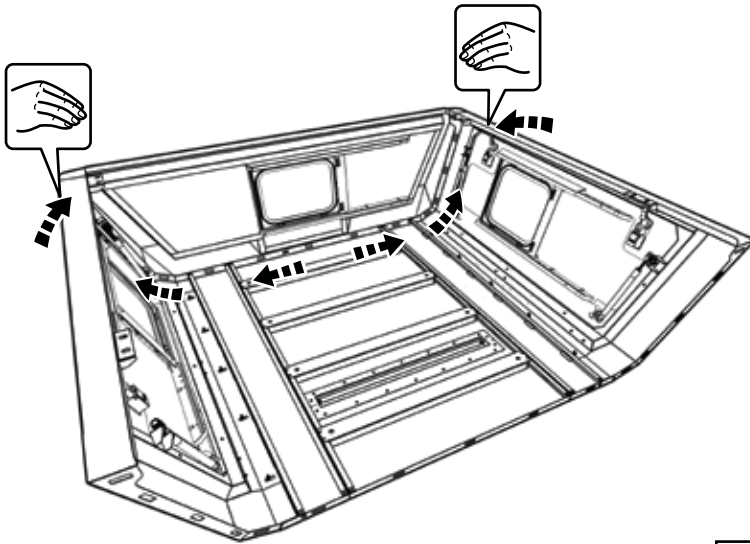

STEP 16

LOCATE THE REAR FLANGE IN THE SMARTCAP PACKAGE AND BRING IT TO YOUR WORK AREA.

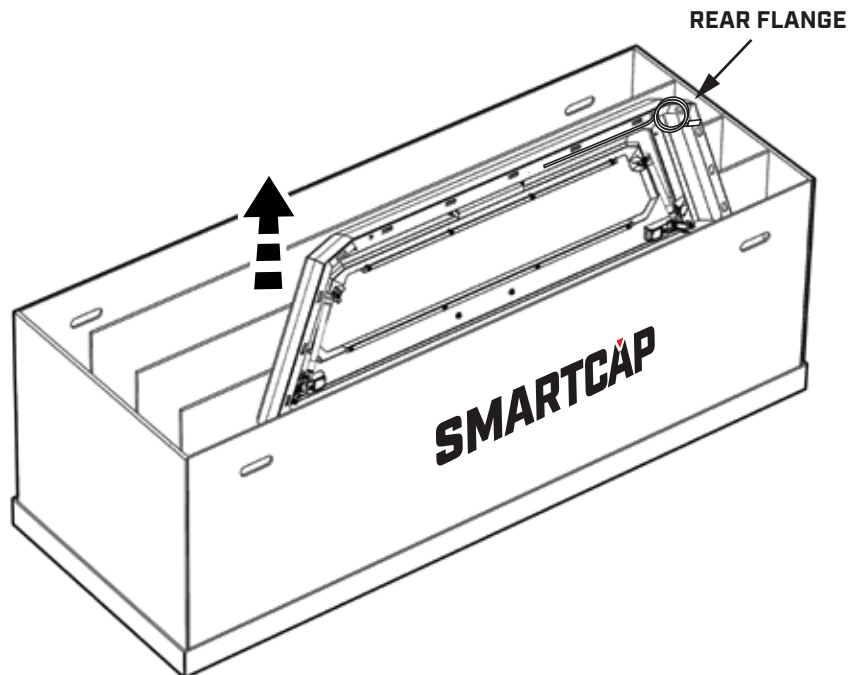

STEP 17

PLACE REAR FLANGE AS SHOWN BELOW.

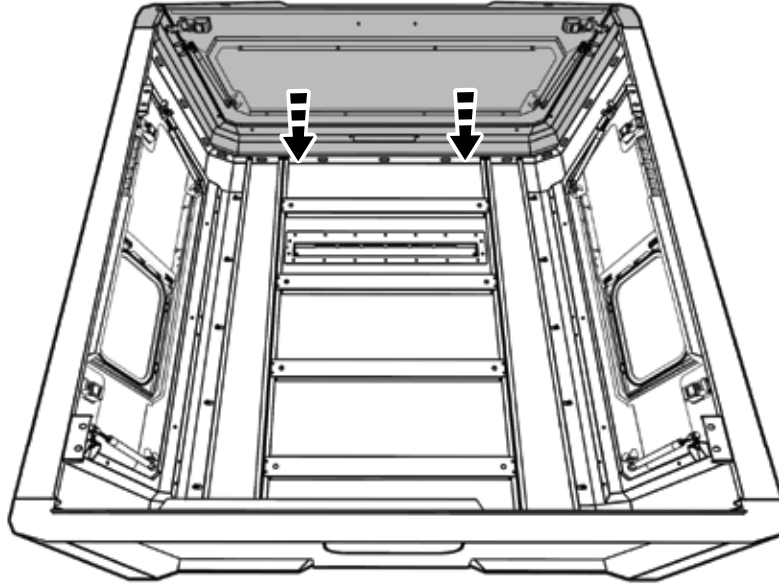

STEP 18

INSTALL HARDWARE ALONG REAR FLANGE WITH BOLT ON INSIDE.



START AT CENTER OF THE REAR FLANGE AND WORK YOUR WAY OUTWARDS.

ADJUST LEFT AND RIGHT PANELS TO ALIGN THE FASTENER BLOCK HOLES.

HAND TIGHTEN ONLY.

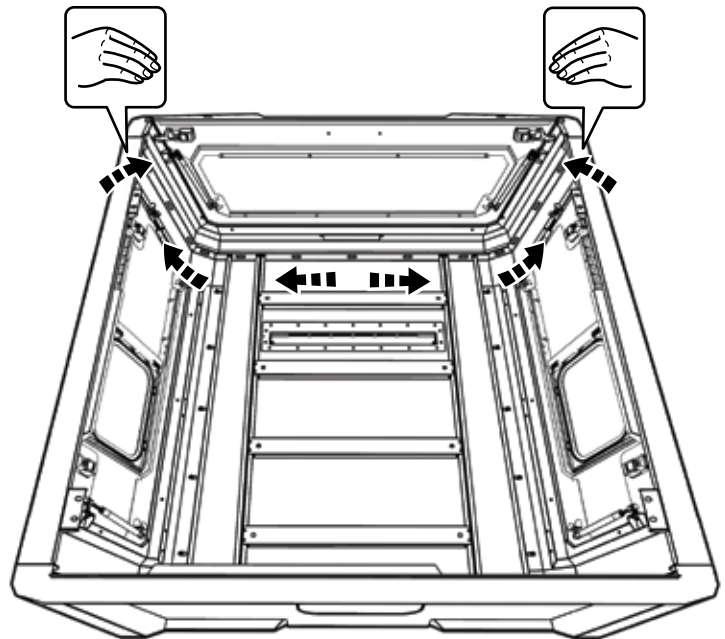
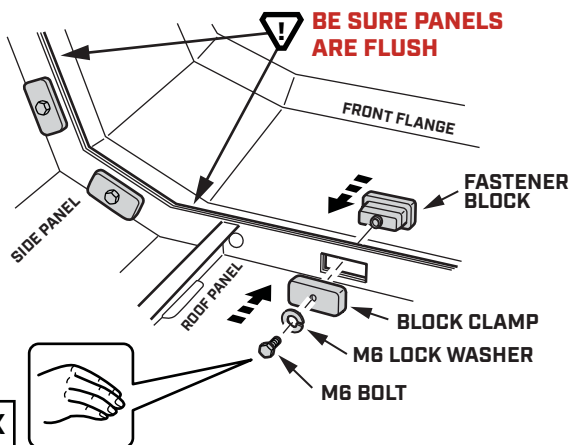

STEP 19

TIGHTEN ALL HARDWARE WITH TORQUE WRENCH
AND 10MM SOCKET TO 3.7 FT. LBS. (5 NEWTON METERS)

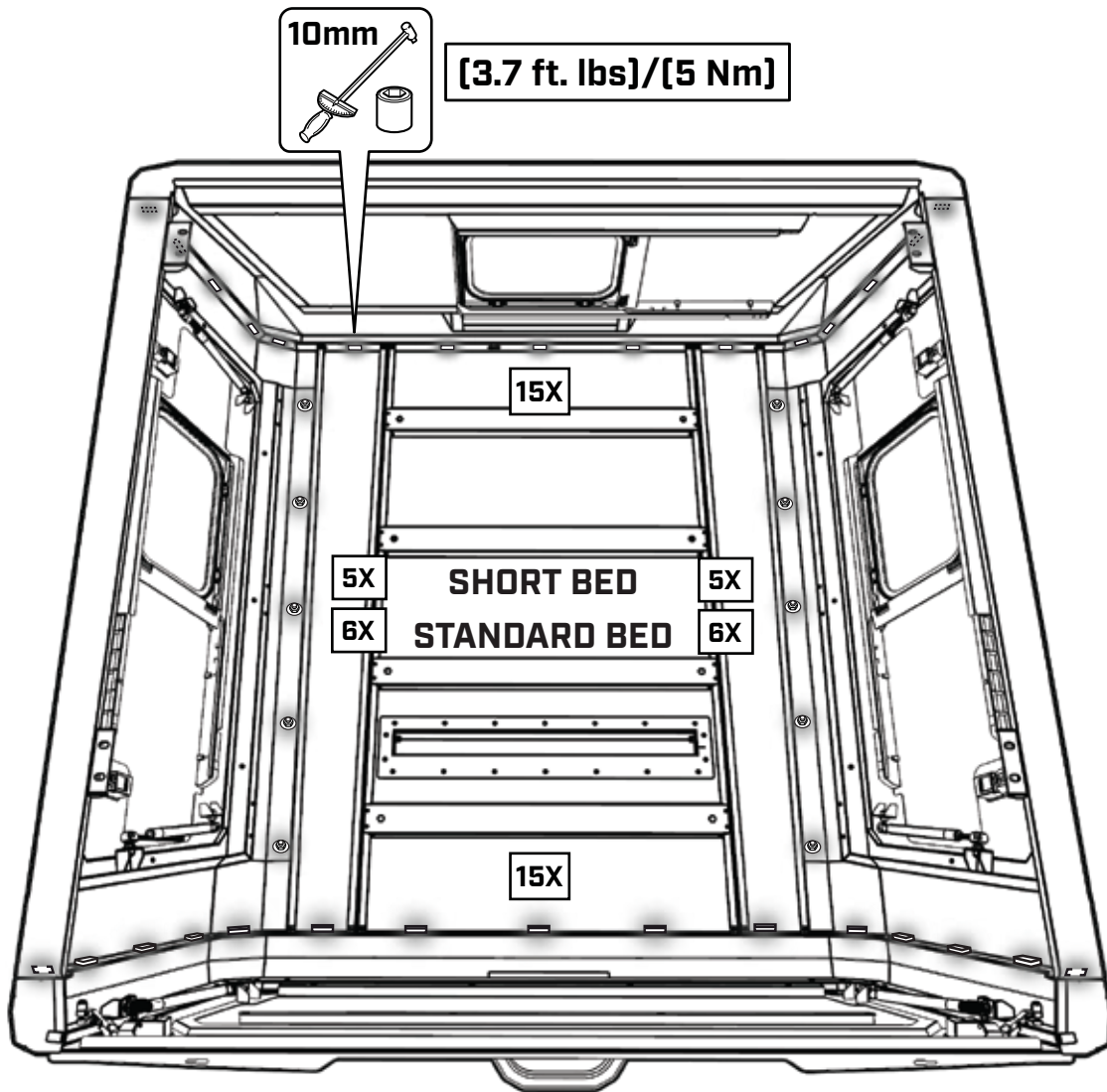

STEP 20

ENSURE THE ENTIRE BOTTOM EDGE OF THE SMARTCAP IS CLEAN.

LOCATE BOTH RETENTION TABS ON THE REAR FLANGE AND BEND EACH TO A 45-DEGREE ANGLE FOR D-RUBBER FITMENT.



LOCATE RETENTION TABS

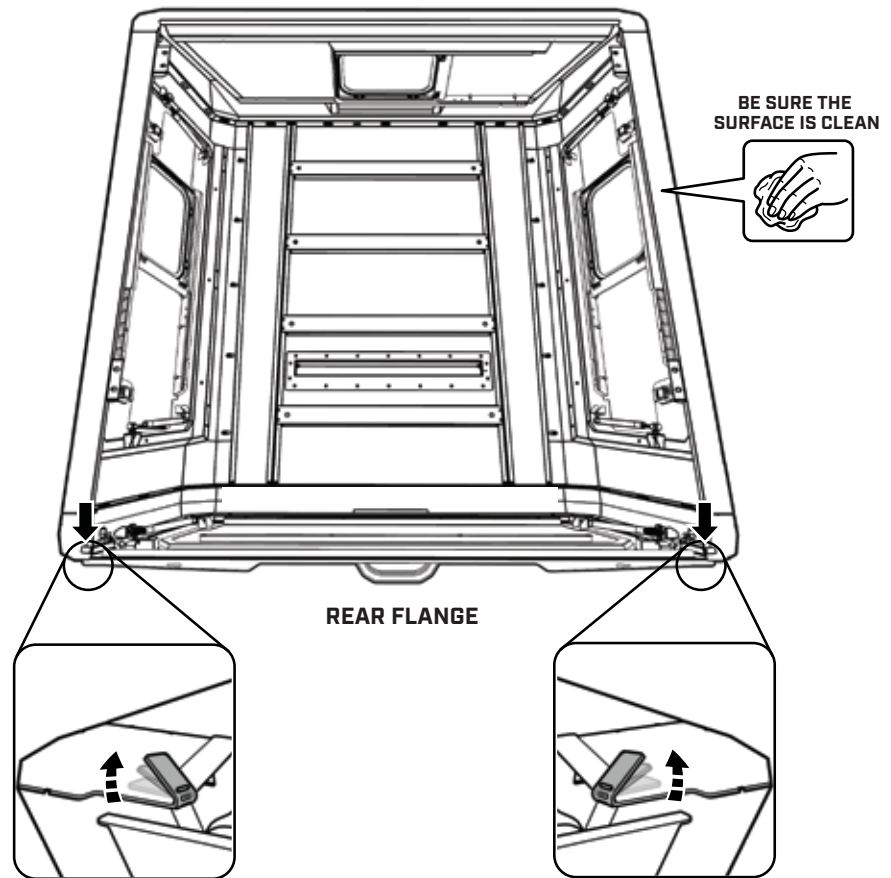

STEP 21

TRIM THE D-RUBBER WITH A CLEAN, STRAIGHT CUT.

APPLY 2-3 INCHES OF GEL SUPER GLUE NEAR THE RETENTION TABS, ALONG THE BOTTOM EDGE OF THE REAR FLANGE

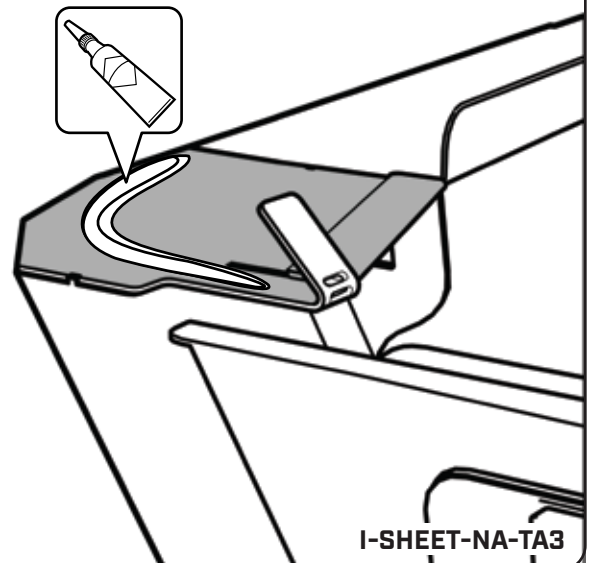
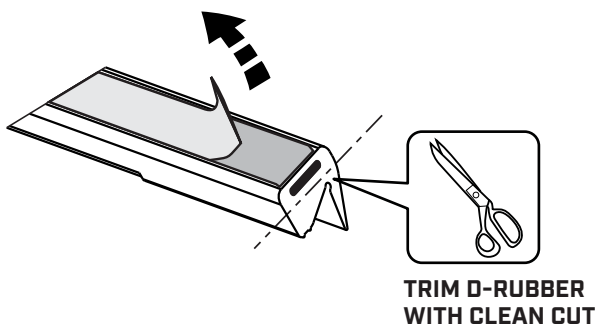

STEP 22

FULLY INSERT THE RETENTION TAB INTO THE SLOT ON THE D-RUBBER. ENSURE THE D-RUBBER IS ORIENTED CORRECTLY WITH ITS PROFILE MATCHING THE CONTOUR OF THE REAR FLANGE.

PRESS DOWN FIRMLY ON THE TAB AND THE D-RUBBER TO BOND IT TO THE REAR FLANGE, CREATING A TIGHT SEAL.

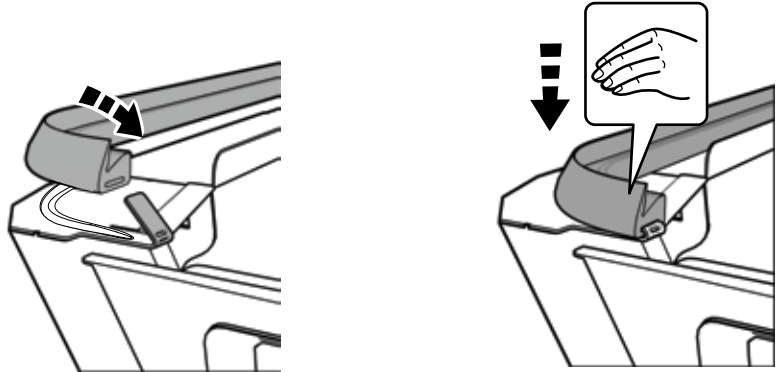

CORRECT D-RUBBER ORIENTATION

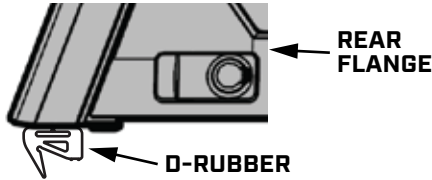

INCORRECT D-RUBBER ORIENTATION

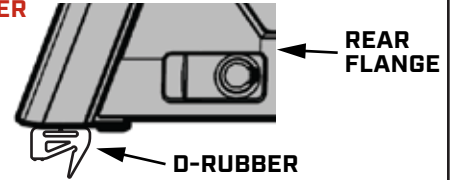

STEP 23

ALIGN THE D-RUBBER ALONG THE SMARTCAP'S EDGE, MAINTAINING A CONSISTENT 1/8 INCH GAP FROM THE EDGE.

START FROM ONE CORNER AND WORK YOUR WAY AROUND THE CAP TO ENSURE PROPER PLACEMENT AND ALIGNMENT.

APPLY 2-3 INCHES OF GEL SUPER GLUE AT THE FRONT CORNERS OF THE SMARTCAP, ALONG THE BOTTOM EDGE OF THE FRONT FLANGE.

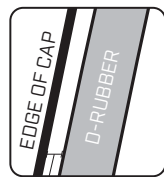

1/8 INCH FROM EDGE

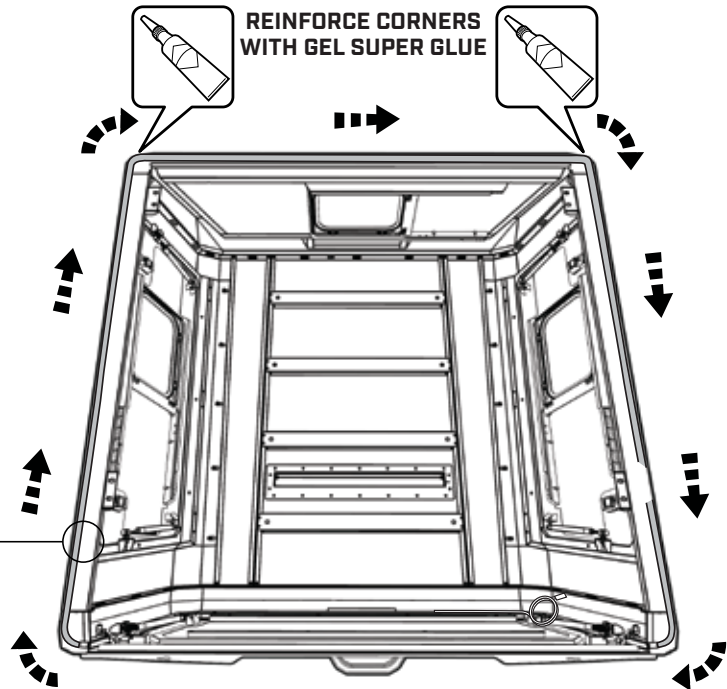

STEP 24

TRIM ANY EXCESS D-RUBBER BEYOND THE EDGE FOR A NEAT FINISH.

APPLY 2-3 INCHES OF GEL SUPER GLUE NEAR THE RETENTION TAB, ALONG THE BOTTOM EDGE OF THE REAR FLANGE. FULLY INSERT THE RETENTION TAB INTO THE SLOT ON THE D-RUBBER.

PRESS DOWN FIRMLY ON THE TAB AND THE D-RUBBER TO BOND IT TO THE REAR FLANGE, CREATING A TIGHT SEAL.

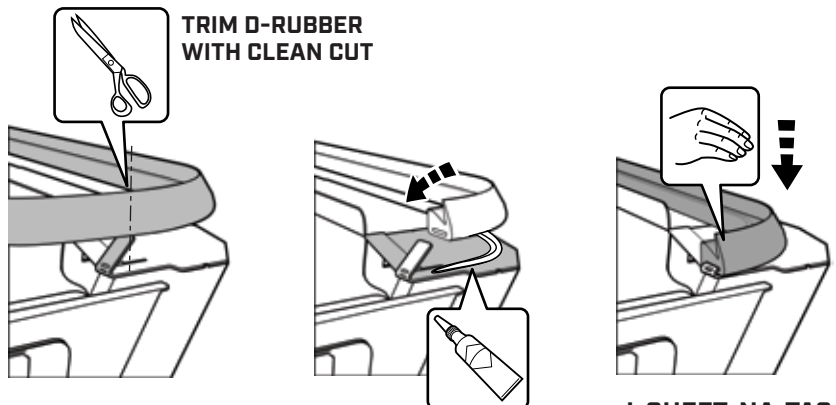

I-SHEET-NA-TA3

INSTALLATION HARDWARE

THREAD BLOCKS

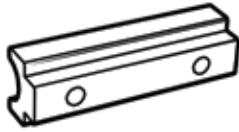

4X

MOUNTING CLAMP

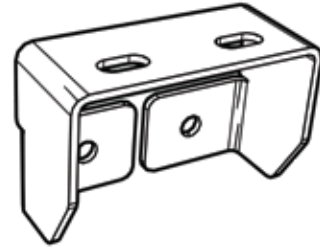

4X

THIN RUBBER PAD

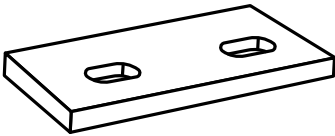

4X

FOAM SEAL TAPE

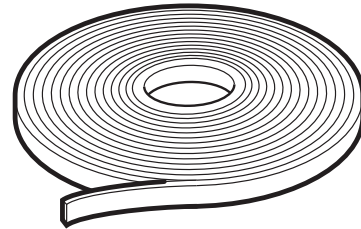

1X

THICK RUBBER PAD

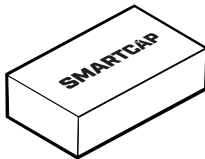

8X

M8 BOLT

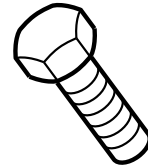

16X

M8 FENDER WASHER



24X

M8 LOCK WASHER



8X

M8 LOCK NUT

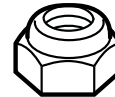

8X

VEHICLE INSTALLATION



IMPORTANT

- ▼ ASSISTANCE WILL BE NEEDED FOR THIS INSTALLATION. FOUR PEOPLE ARE RECOMMENDED TO LIFT THE SMARTCAP ONTO THE VEHICLE.
- ▼ AVOID PINCHING OR CRUSHING HANDS AND FINGERS.
- ▼ READ THROUGH THE ENTIRE PROCEDURE BEFORE STARTING.

I-SHEET-NA-TA3

STEP 25

REMOVE THE ADHESIVE BACKING FROM THE THICK RUBBER PAD.

PLACE PADS NEXT TO D-RUBBER ALONG THE BOTTOM EDGE OF SMARTCAP AT INDICATED LOCATIONS.



PLACE PADS PERPENDICULAR TO D-RUBBER

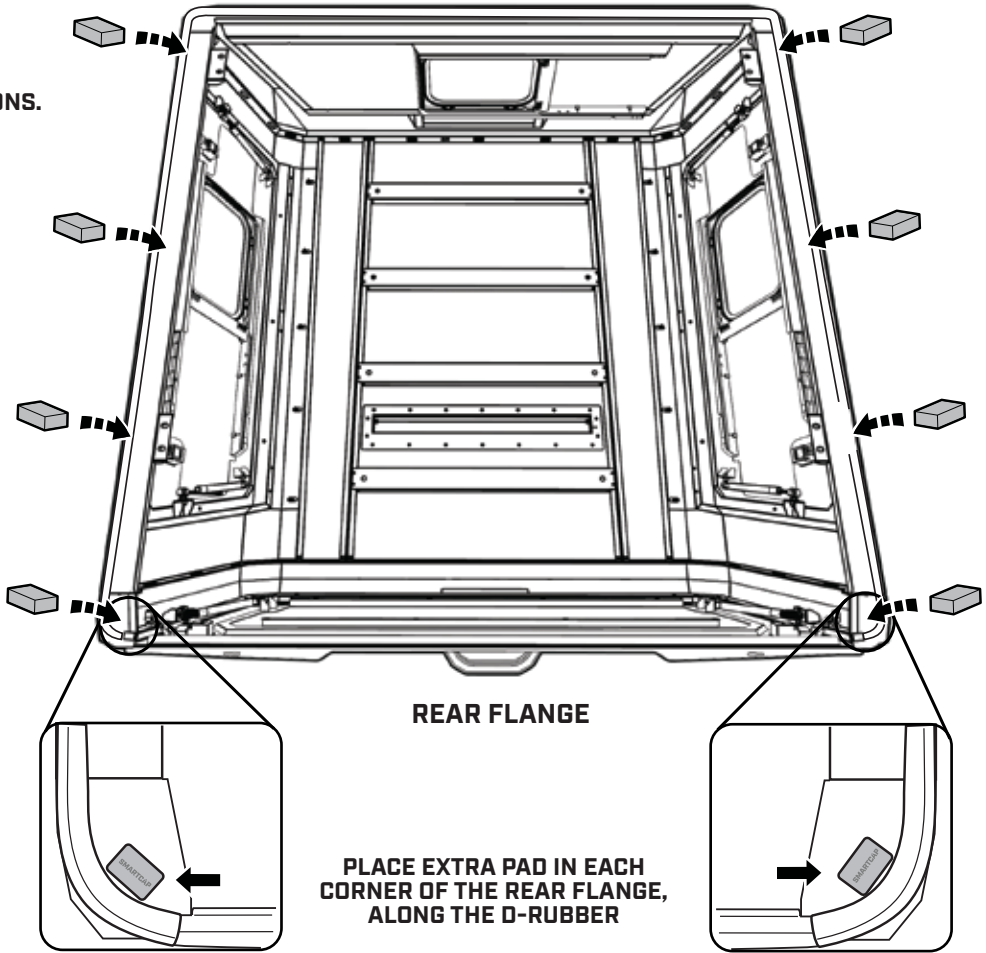
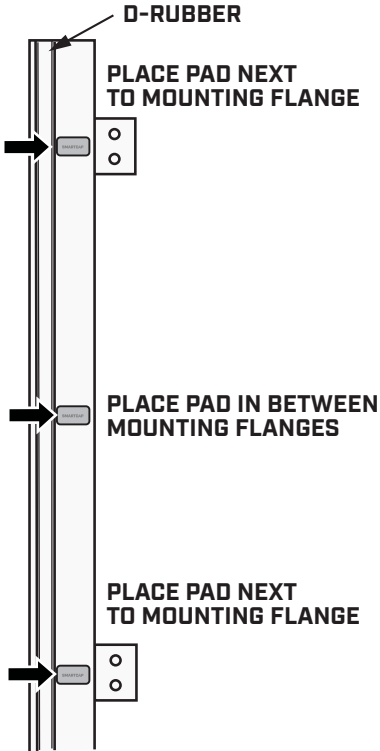

STEP 26

INSPECT THE TRUCK BED. IF FRONT EDGE IS LOWER THAN THE SIDES, ADD FOAM SEAL TAPE TO THE FRONT EDGE OF THE BED.

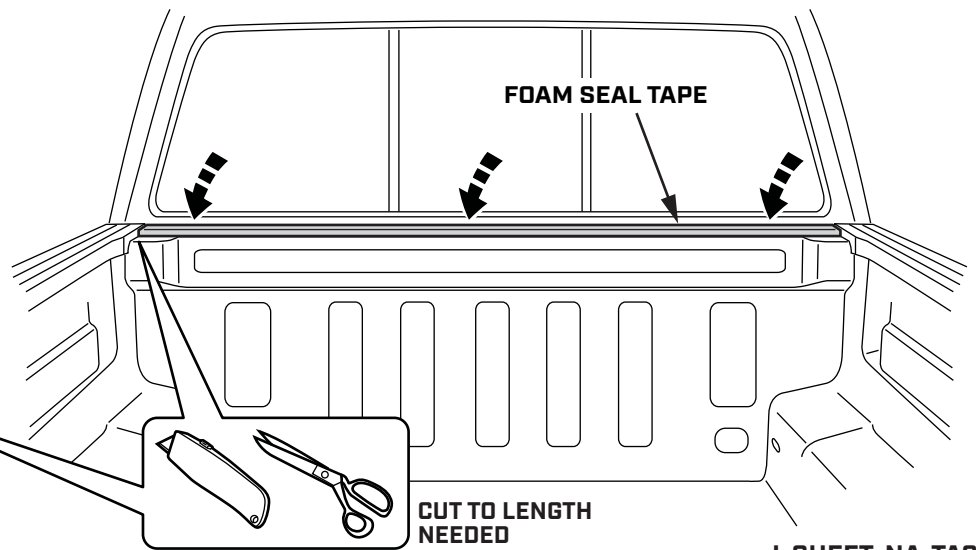
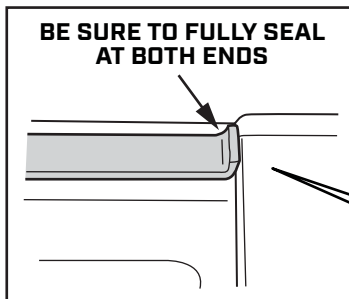
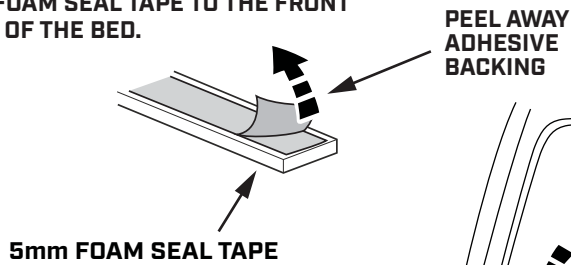
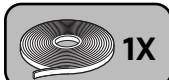

I-SHEET-NA-TA3

STEP 27

USE 4 PEOPLE TO LIFT THE ASSEMBLED SMARTCAP ONTO THE TRUCK BED.

TO AVOID DAMAGE TO THE D-RUBBER, DO NOT SLIDE THE SMARTCAP INTO PLACE.

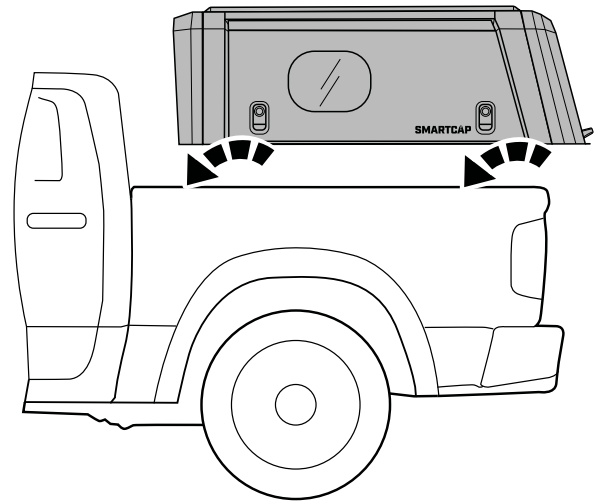
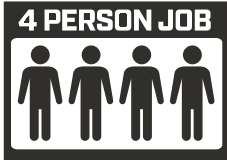

STEP 28

CHECK THAT THE SMARTCAP IS PROPERLY POSITIONED AND CENTERED ON THE TRUCK BED.

IT'S IMPORTANT THAT THE SMARTCAP IS NOT PUSHED TOO FAR FORWARD, LEAVING A GAP BETWEEN THE SMARTCAP AND THE CAB.

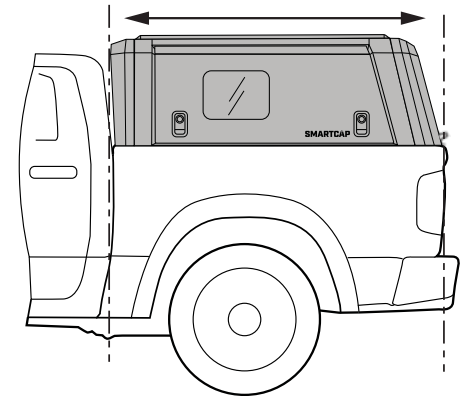
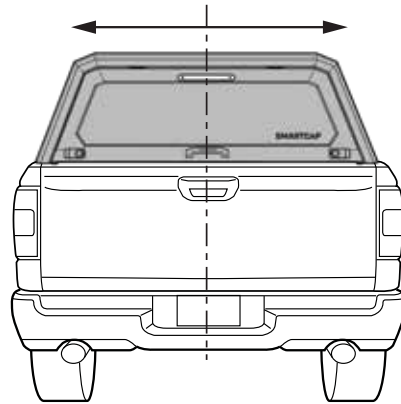

STEP 29

WALK AROUND THE TRUCK BED TO MAKE SURE THE D-RUBBER FITMENT IS CORRECT AND THAT THE RUBBER LIP IS PROPERLY TUCKED UNDERNEATH THE CAP.

CHECK THE OPERATION OF THE TAILGATE. THE LIP OF THE D-RUBBER SHOULD RUB THE TAILGATE WHEN OPENING AND CLOSING WITH EASE.

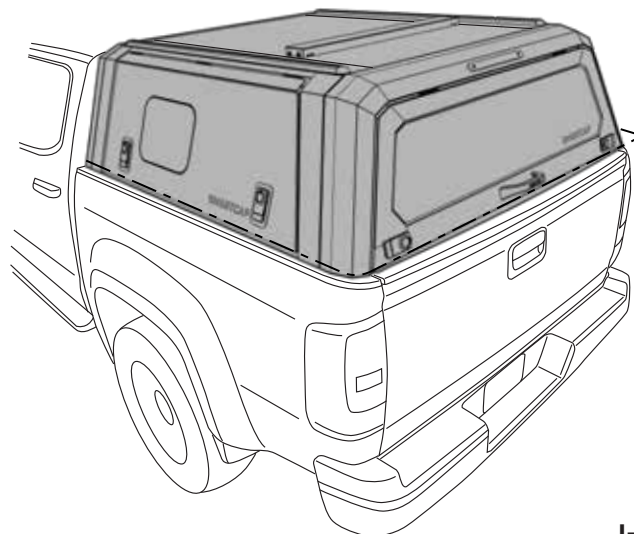

I-SHEET-NA-TA3

STEP 30

REMOVE THE ADHESIVE BACKING FROM THE THIN RUBBER PADS.

APPLY THIN RUBBER PAD TO THE SURFACE OF EACH MOUNTING BRACKET AS SHOWN BELOW.

REPEAT ON ALL FOUR BRACKETS

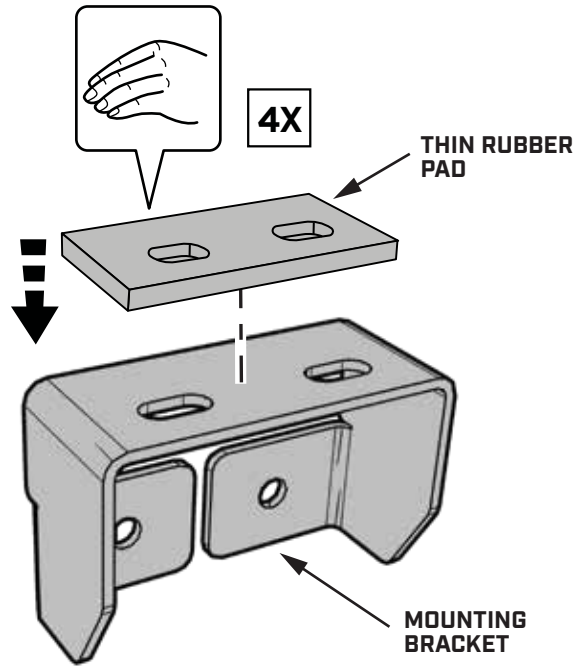
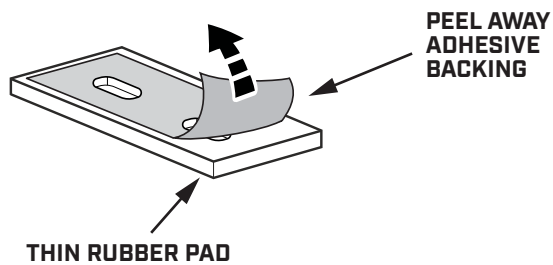

STEP 31

INSERT TWO THREAD BLOCKS INTO THE RIGHT TRAIL RAIL, ALIGNING THEM WITH THE TRAIL RAIL MOUNTS ON THE SMARTCAP.

REPEAT ON OPPOSITE SIDE

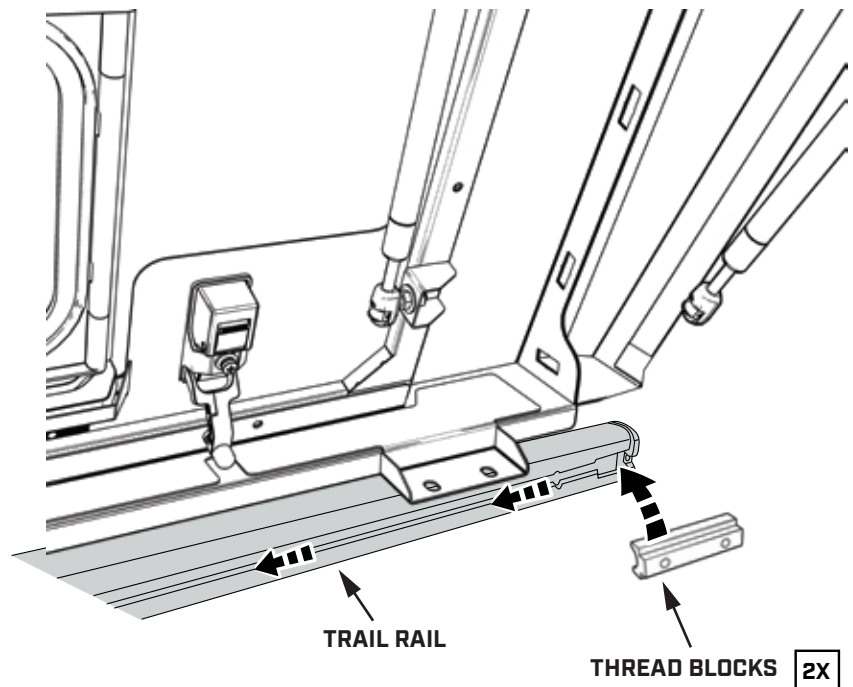

I-SHEET-NA-TA3

STEP 32

PLACE THE MOUNTING BRACKET
UNDERNEATH THE SMARTCAP
TRAIL RAIL MOUNT AS SHOWN BELOW.

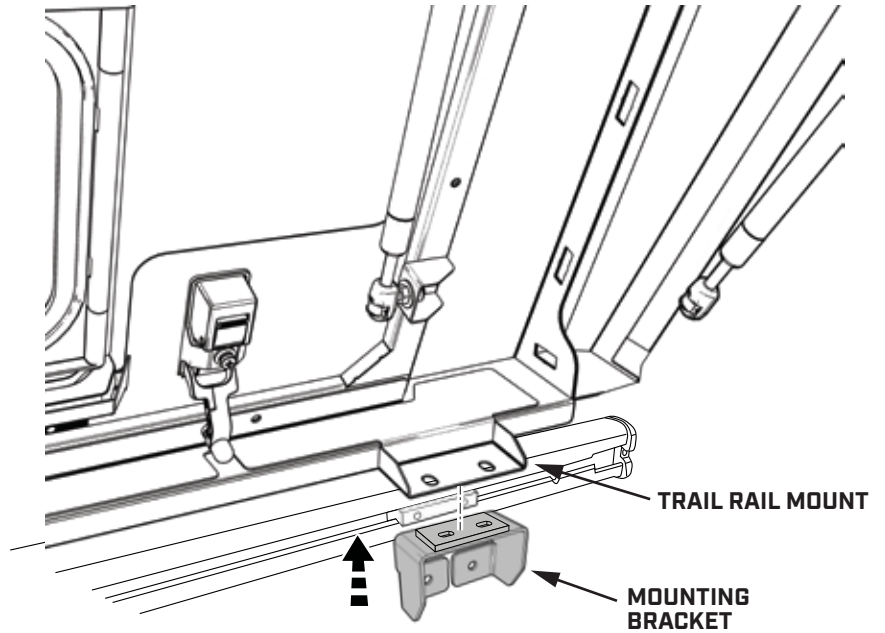

STEP 33

SECURE THE MOUNTING BRACKET TO
THE THREAD BLOCK USING M8 BOLT,
M8 LOCK WASHER AND, M8 FENDER
WASHER AS SHOWN BELOW.

HAND TIGHTEN ONLY.

REPEAT ON ALL FOUR CORNERS

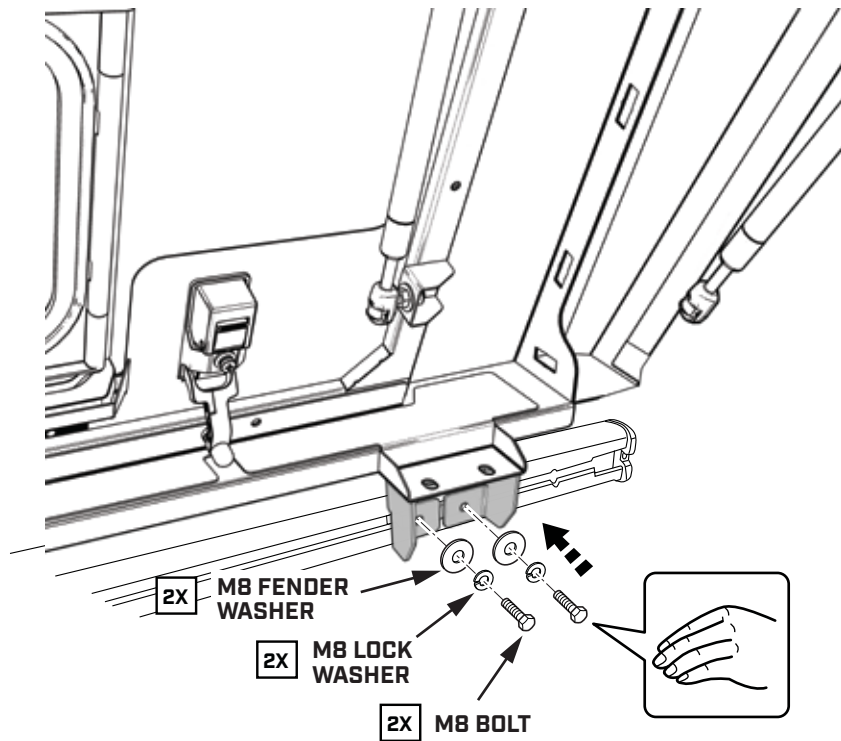

I-SHEET-NA-TA3

STEP 34

SECURE THE MOUNTING BRACKET TO THE SMARTCAP USING M8 BOLT, M8 FENDER WASHER AND, M8 LOCK NUT AS SHOWN BELOW.

HAND TIGHTEN ONLY.

REPEAT ON ALL FOUR CORNERS

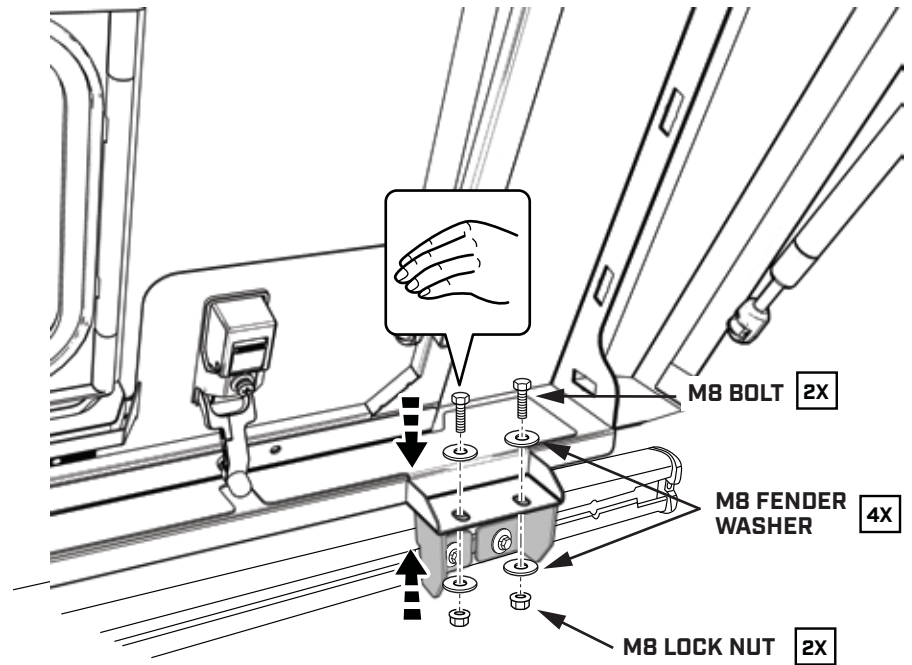

STEP 35

TIGHTEN MOUNTING CLAMPS USING TORQUE WRENCH AND 13MM SOCKET TO 4.4 FT. LBS. (6 NEWTON METERS)

REPEAT ON ALL FOUR CORNERS

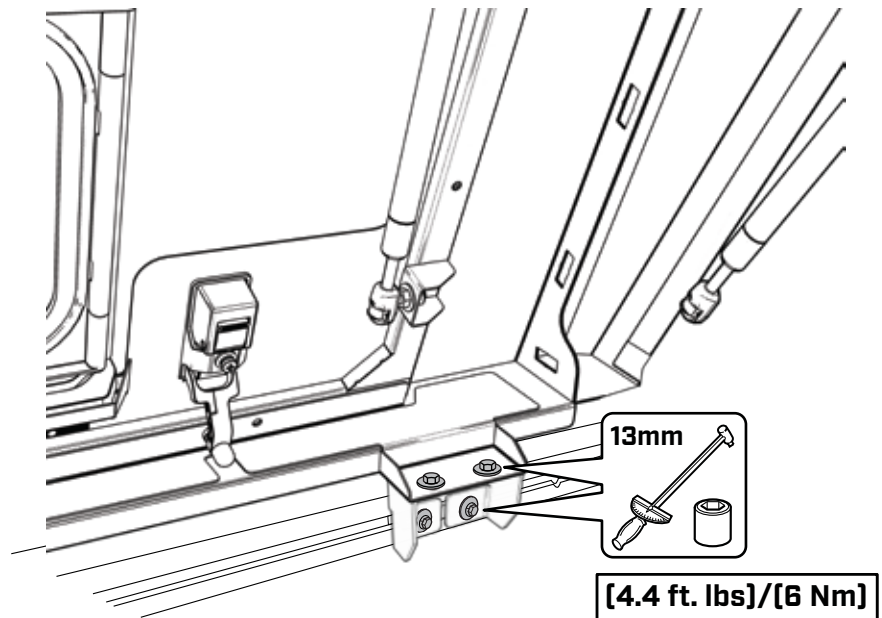

I-SHEET-NA-TA3

THIRD BRAKE LIGHT HARDWARE

T-HARNESS

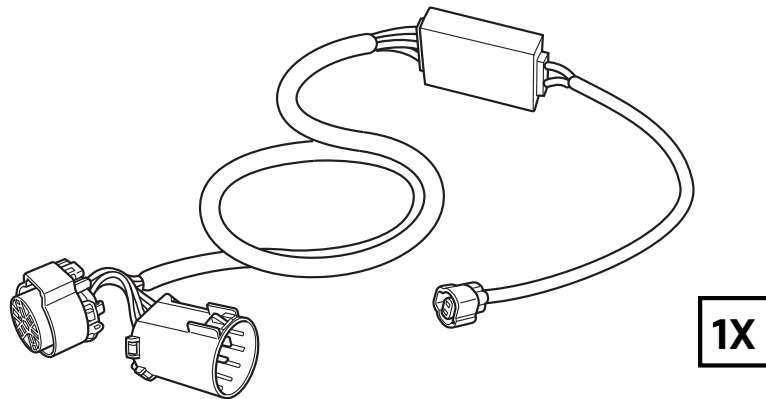

1X

CABLE TIE

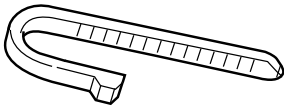

8X

CABLE TIE BASE

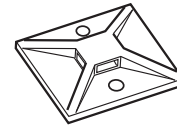

2X



IMPORTANT

- ▼ BE SURE THE VEHICLE IS TURNED OFF FOR THIS INSTALLATION.
- ▼ READ THROUGH THE ENTIRE PROCEDURE BEFORE STARTING AND FOLLOW THE STEPS CAREFULLY TO ENSURE THE THIRD BRAKE LIGHT WILL FUNCTION PROPERLY.
- ▼ USE A TEST LIGHT TO CHECK FOR SUCCESSFUL INSTALLATION.

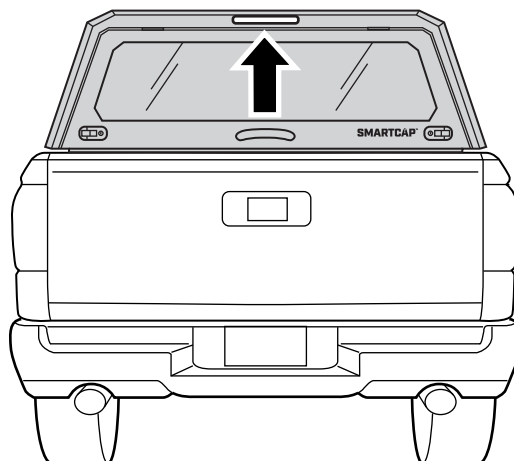

I-SHEET-NA-TA3

STEP 36

REMOVE THE BOLTS HOLDING THE DRIVER SIDE TAILLIGHT ASSEMBLY.

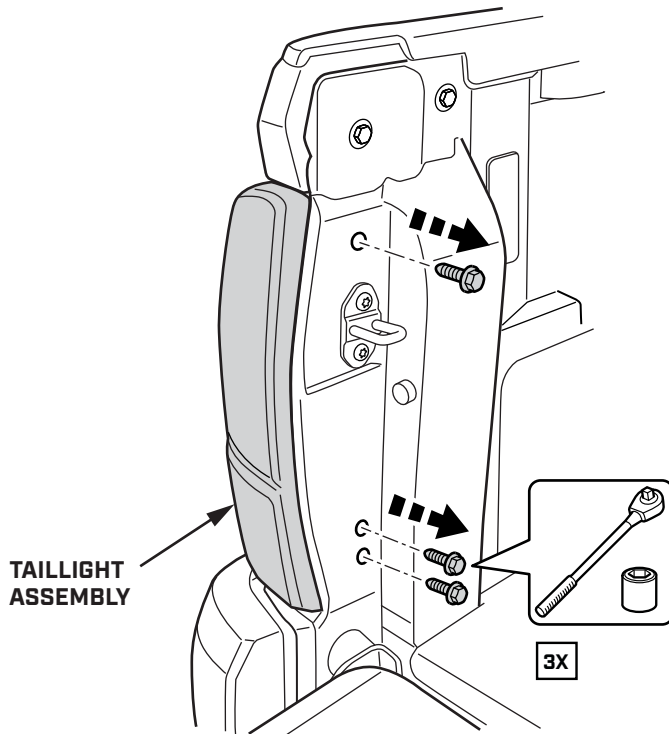

STEP 37

PLACE THE TAILLIGHT ASSEMBLY CAREFULLY ON THE TAILGATE. DO NOT UNPLUG ANY CONNECTORS.

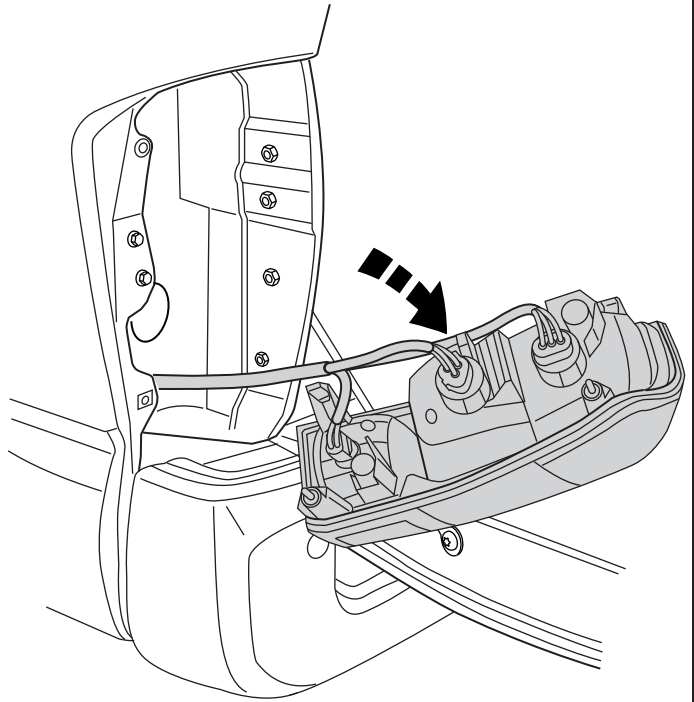

STEP 38

USING A 3/8 INCH DRILL BIT, DRILL A GUIDE HOLE IN THE LEFT REAR CORNER OF THE TRUCK BED. MAKE SURE THE HOLE IS DRILLED WITHIN A HALF INCH FROM THE BEND IN THE PANEL.

ONCE COMPLETE, USE THE 3/4 INCH DRILL BIT TO BORE OUT THE HOLE.

IF NECESSARY, REMOVE ANY BURRS OR SHARP EDGES WITH A METAL FILE.

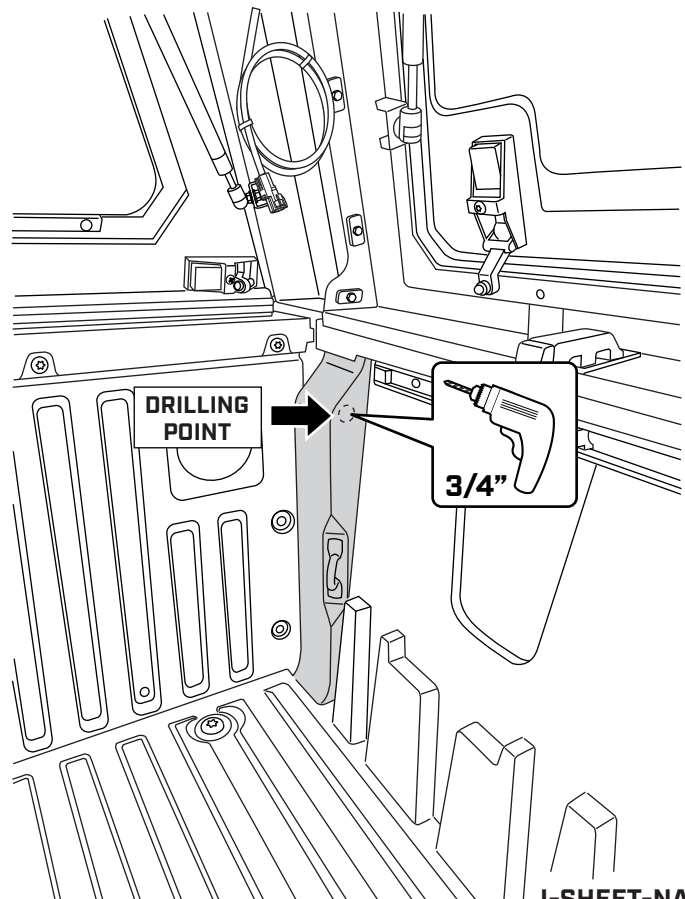

I-SHEET-NA-TA3

STEP 39

ROUTE THE THIRD BRAKE LIGHT EXTENSION HARNESS FROM THE INSIDE OF THE CAP AND THROUGH THE 3/4" DRILLED HOLE. CAREFULLY FEED THE HARNESS PAST THE TAILLIGHT CAVITY, ENSURING THAT IT EXTENDS TOWARDS THE REAR BUMPER OF THE TRUCK.

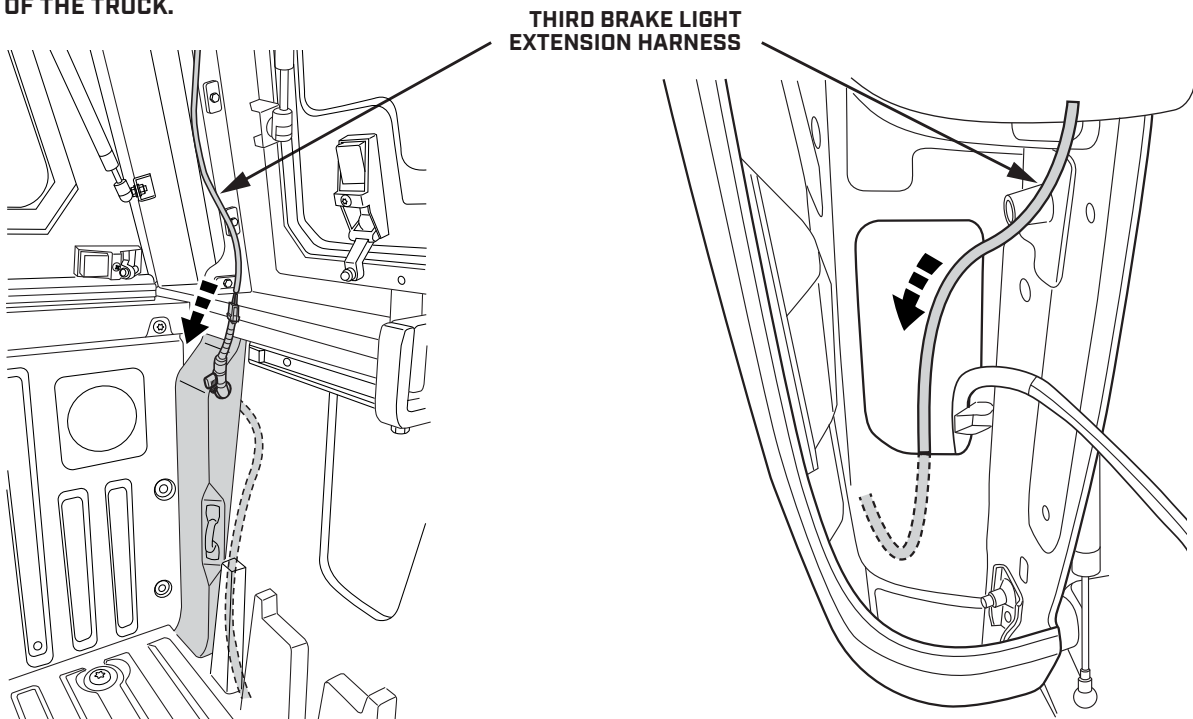

STEP 40

RETRIEVE THE SUPPLIED T-HARNESS FROM YOUR FITMENT KIT.

CONNECT THE 2-PIN FEMALE PLUG OF THE T-HARNESS INTO THE MALE 2-PIN PLUG OF THE THIRD BRAKE LIGHT EXTENSION HARNESS.

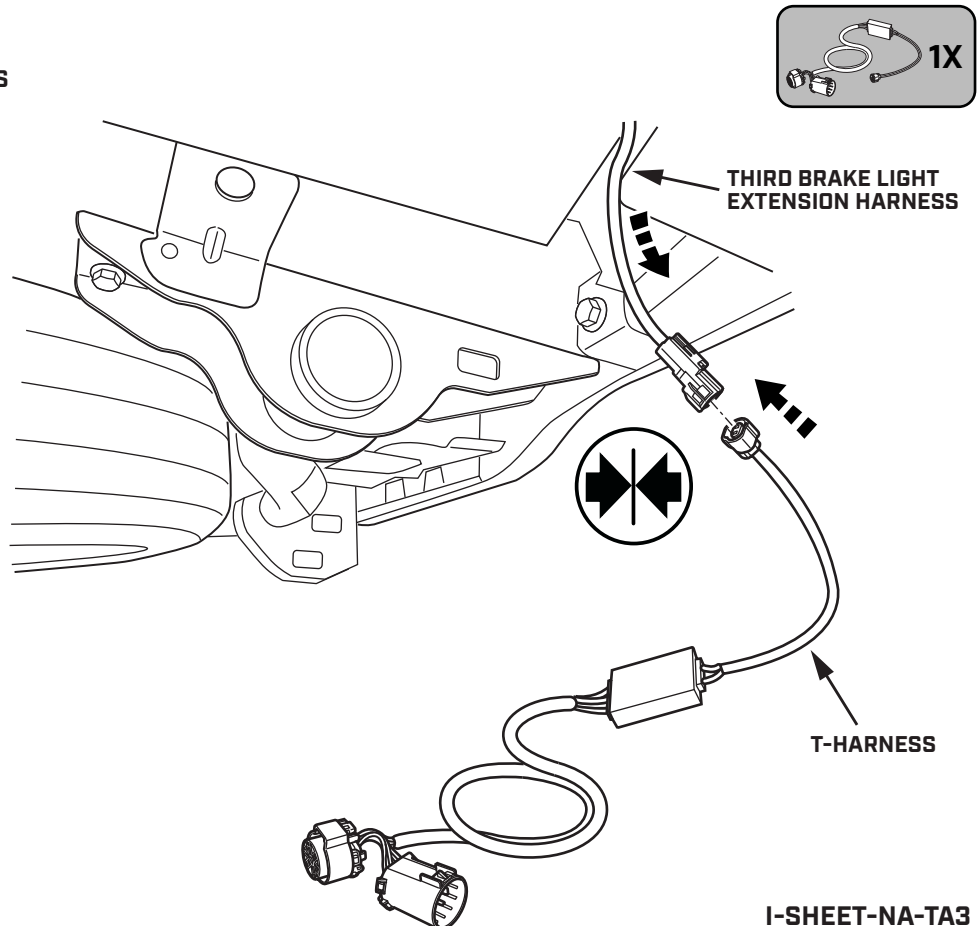

STEP 41

FROM UNDERNEATH THE VEHICLE, ROUTE THE T-HARNESS ABOVE THE FRAME, ALONG THE INSIDE OF THE REAR BUMPER AND TOWARD THE 7 WAY TRAILER HITCH CONNECTOR NEAR THE TRAILER HITCH.

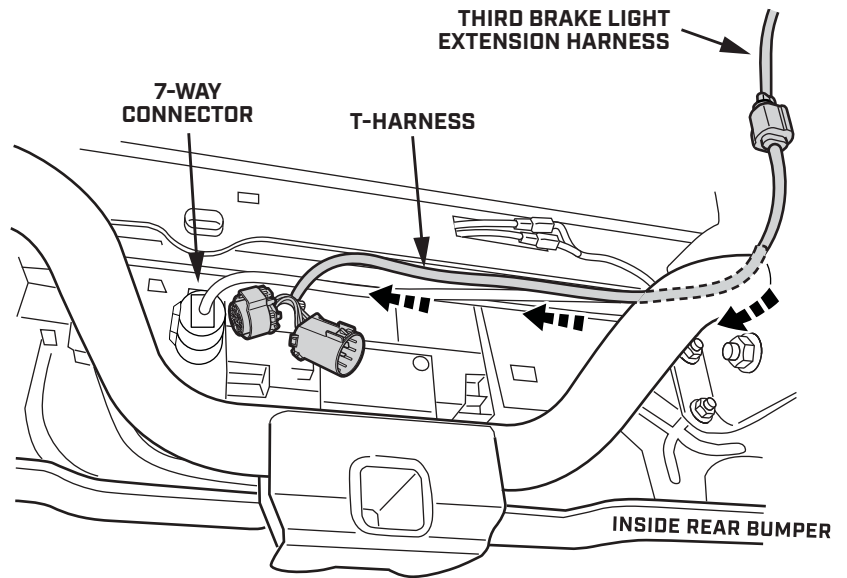

STEP 42

DISCONNECT THE PLUG FROM THE BACK OF THE 7-WAY CONNECTOR.

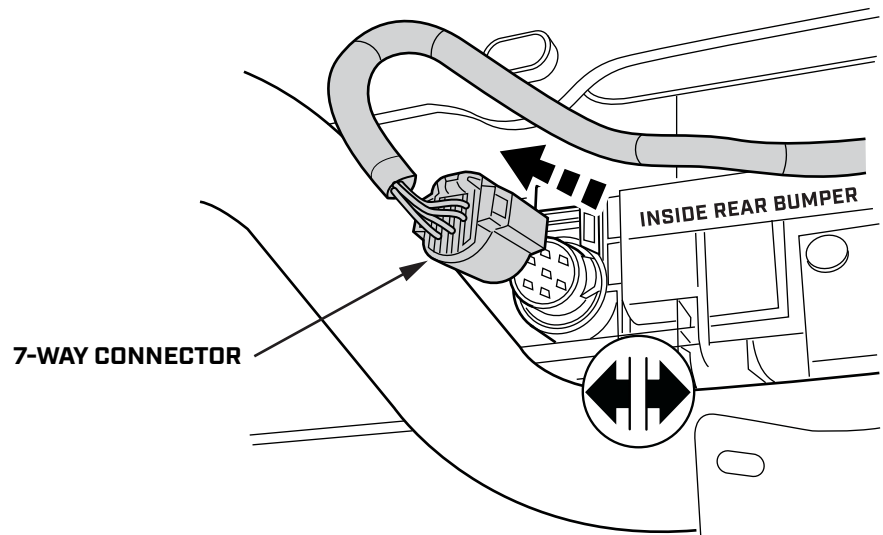

STEP 43

PLUG THE NEW T-HARNESS INTO THE BACK OF THE 7-WAY CONNECTOR.

CONNECT THE ORIGINAL PLUG INTO THE FEMALE SIDE OF THE T-HARNESS.

BE SURE PLUGS ARE FULLY INSERTED AND LOCKING TABS ARE IN PLACE.

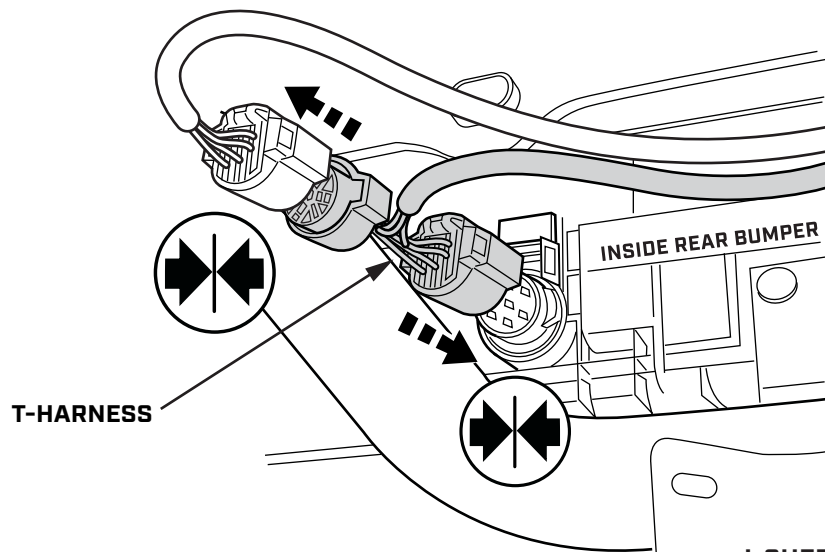

I-SHEET-NA-TA3

STEP 44

BUNDLE EXTRA T-HARNESS LENGTH IN THE TAILLIGHT CAVITY AND SECURE WITH CABLE TIES.

REINSTALL THE TAILLIGHT ASSEMBLY.

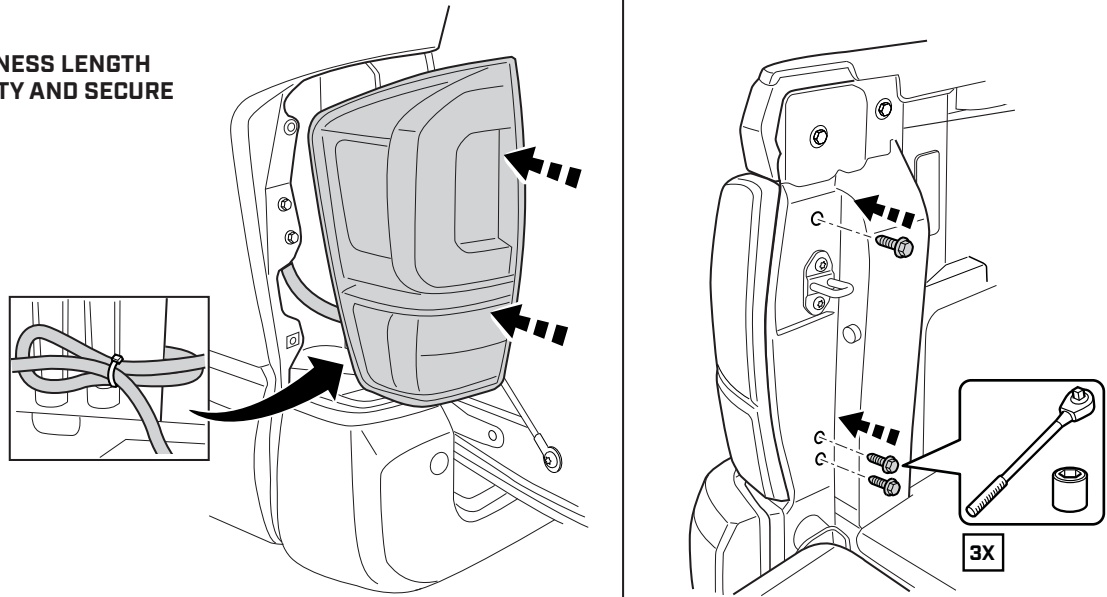

STEP 45



TEST YOUR BRAKE LIGHTS & TURN SIGNALS

- ▼ START THE TRUCK. SOME MODELS MAY TAKE UP TO 30 SECONDS FOR THE VEHICLE TO DETECT THE NEW CONNECTION.
- ▼ CHECK THE BRAKE LIGHTS AND TURN SIGNALS TO BE SURE THEY ARE FUNCTIONING PROPERLY.
- ▼ ONCE YOU HAVE CONFIRMED THAT THE LIGHTS ARE WORKING CORRECTLY, SECURE THE HARNESS WITH CABLE TIES.
- ▼ BE SURE NOT TO INTERFERE WITH ANY MOVING PARTS ON THE VEHICLE.
- ▼ YOUR CAP INSTALLATION IS COMPLETE.

WARNING: SOME VEHICLES MAY SHOW A "DISCONNECTED TRAILER" ERROR. IF THIS OCCURS AND YOUR TRUCK IS EQUIPPED WITH VEHICLE TOWING SOFTWARE, NAVIGATE THE CONTROLS TO MANUALLY ENABLE POWER TO THE 7-WAY CONNECTOR. THIS CAN APPEAR AS "ENABLE AUXILIARY" OR "ENABLE TRAILER." IF CHMSL DOES NOT WORK, SHUT OFF THE VEHICLE. WAIT 10 SECONDS AND RESTART. WAIT AN ADDITIONAL 10 SECONDS FOR THE VEHICLE TO DETECT CHMSL.

IMPORTANT: WHEN ATTACHING A TRAILER, ALWAYS TEST THE TRAILER LIGHT FUNCTIONALITY WHILE USING THIS SYSTEM.



THANKS FOR YOUR PURCHASE.
PLEASE LET US KNOW IF YOU HAVE ANY QUESTIONS.

[SMARTCAP.COM](https://www.smartcap.com)

[SUPPORT.NA@SMARTCAP.COM](mailto:support.na@smartcap.com) - NORTH AMERICA

[SUPPORT.SA@SMARTCAP.COM](mailto:support.sa@smartcap.com) - REST OF WORLD



I-SHEET-NA-TA3