

**SMARTCAP®**

# **INSTRUCTION GUIDE**

## **SILVERADO/SIERRA EDITION**

### **2021-CURRENT (4th Generation)**



- ▼ **PREPARE A CLEAN WORK AREA.**
- ▼ **WE RECOMMEND A MINIMUM OF 2 PEOPLE FOR ASSEMBLY AND 4 PEOPLE FOR INSTALLATION.**
- ▼ **ENSURE THE REQUIRED TOOLS ARE PRESENT AND ALL HARDWARE CONTENTS ARE ACCOUNTED FOR.**
- ▼ **NEVER USE ACETONE OR THINNERS ON PAINTED PARTS.**
- ▼ **READ THROUGH THE ENTIRE INSTRUCTION GUIDE BEFORE STARTING THIS PROCEDURE AND FOLLOW THE STEPS CAREFULLY TO AVOID ANY DAMAGE TO THE COMPONENTS OR THE VEHICLE.**

**SMARTCAP.COM**

SUPPORT.NA@SMARTCAP.COM - NORTH AMERICA

SUPPORT.SA@SMARTCAP.COM - REST OF WORLD



I-SHEET-NA-S2

## TOOLS REQUIRED



## IMPORTANT

- ▼ USE ONLY THE TOOLS RECOMMENDED ABOVE.
- ▼ USE ONLY THE HARDWARE PROVIDED IN THIS KIT.
- ▼ ASSISTANCE WILL BE NEEDED FOR THIS INSTALLATION. FOUR PEOPLE ARE RECOMMENDED TO LIFT THE SMARTCAP ONTO THE VEHICLE.
- ▼ AVOID PINCHING OR CRUSHING HANDS AND FINGERS.
- ▼ INSPECT ALL KIT COMPONENTS FOR DAMAGE BEFORE ASSEMBLY.
- ▼ NEVER USE ACETONE OR THINNERS ON PAINTED PARTS.

## COMPONENTS

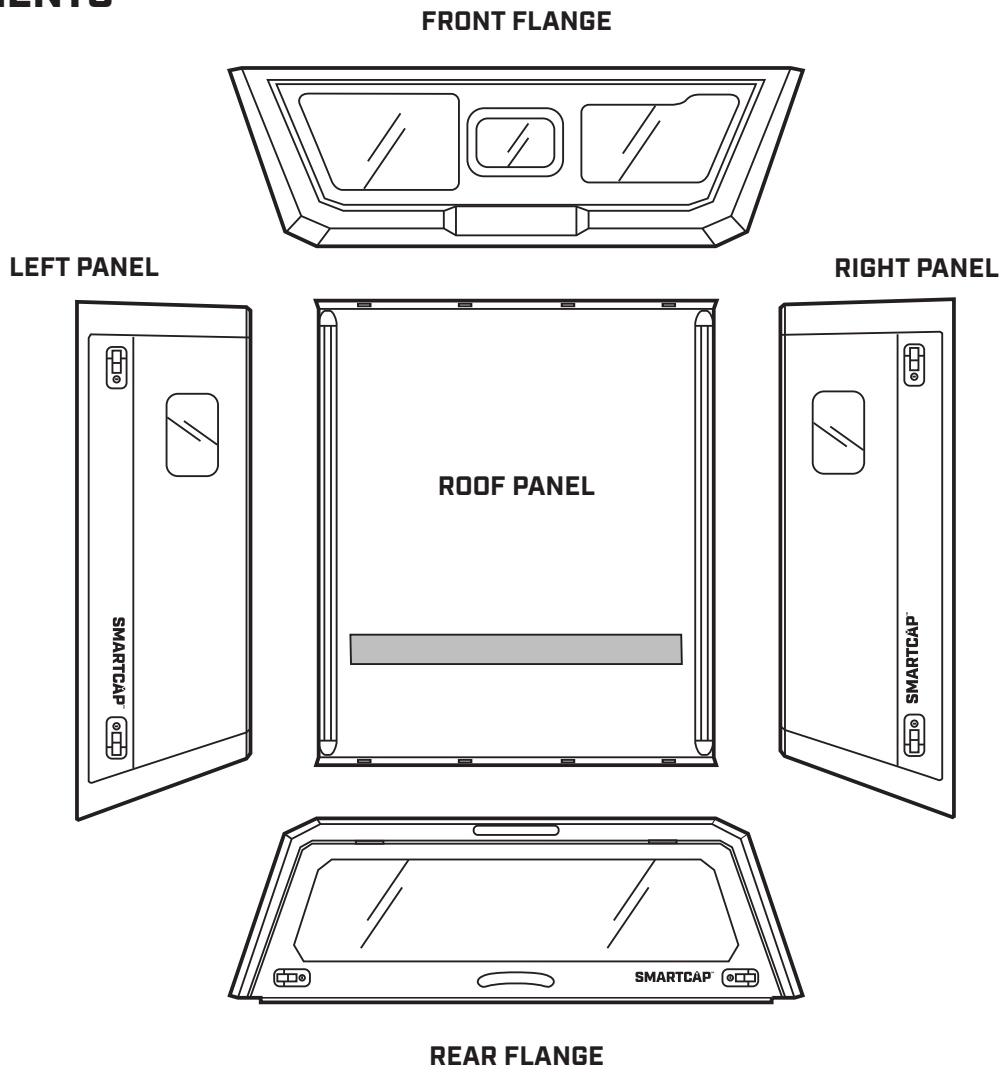

I-SHEET-NA-S2

# ASSEMBLY HARDWARE



## IMPORTANT

▼ DETERMINE WHICH VERSION YOUR FITMENT KIT CONTAINS. (VERSION A OR VERSION B)

### [PRE-FASTENED TO FLANGES]

#### VERSION A

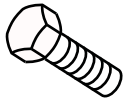

M6  
BOLT  
28X

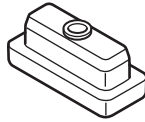

FASTENER  
BLOCK  
28X

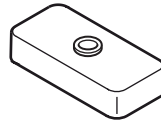

FASTENER BLOCK  
CLAMP  
28X



M6 LOCK  
WASHER  
28X

#### VERSION B



M6  
BOLT  
28X

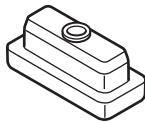

FASTENER  
BLOCK  
28X

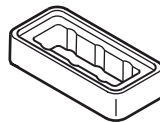

FASTENER BLOCK  
CLAMP  
28X



M6 LOCK  
WASHER  
28X



FASTENER BLOCK  
LOADSPREADER  
28X

### D-RUBBERER 1X

#### VERSION A

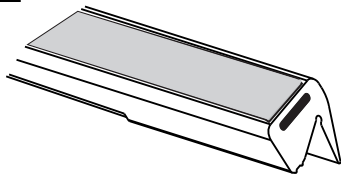

#### VERSION B

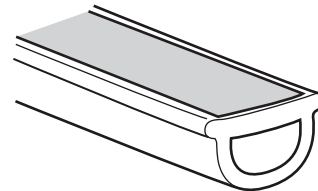

### SPARE HARDWARE 1X

#### VERSION A

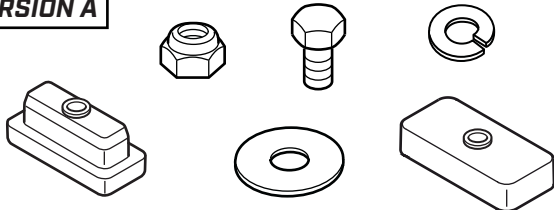

#### VERSION B

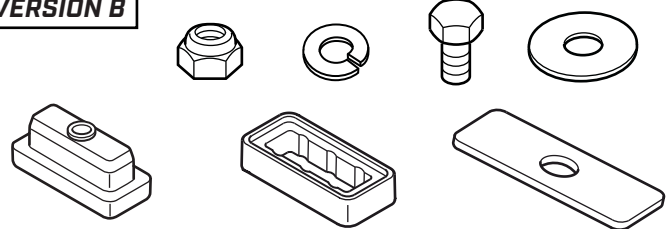

### [PRE-FASTENED TO ROOF PANEL]



M6  
LOCK  
NUT

10X

SHORT BED

12X

STANDARD BED



M6  
FENDER  
WASHER

10X

SHORT BED

12X

STANDARD BED

# STEP 1



**IMPORTANT**



▼ BE SURE TO REMOVE ALL FIVE PANELS FROM THEIR PACKAGING AND INSPECT THE PAINTED SURFACES PRIOR TO ASSEMBLY, AS SMARTCAP WILL NOT ACCEPT PAINT DAMAGE WARRANTY CLAIMS AFTER ASSEMBLY IS COMPLETED. IF MANUFACTURING IMPERFECTIONS OR SHIPPING DAMAGES ARE FOUND, DO NOT CONTINUE WITH THE ASSEMBLY PROCESS AND CONTACT [SUPPORT.NA@SMARTCAP.COM](mailto:SUPPORT.NA@SMARTCAP.COM).

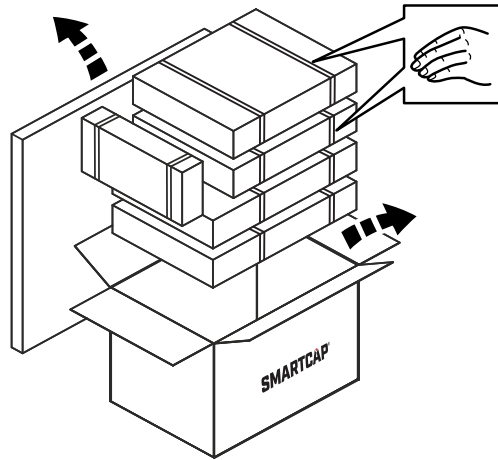

# STEP 2

PLACE THE ROOF PANEL WHERE YOU PLAN TO ASSEMBLE THE CAP AND USE THE LID AS A WORK SURFACE.

**STICKER SIDE UP**

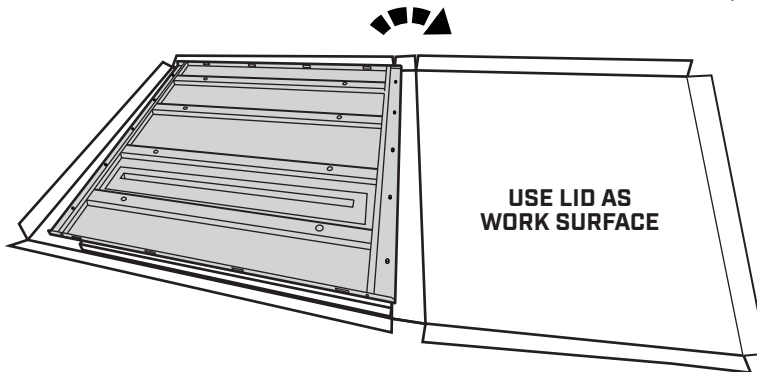
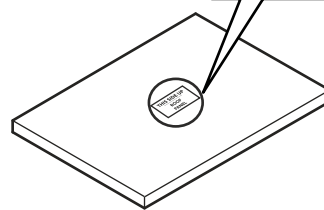

# STEP 3

USE A 10MM COMBINATION WRENCH TO REMOVE ALL HARDWARE FROM THE ROOF PANEL AND SAVE FOR REUSE.



**AIR VENT INDICATES REAR**

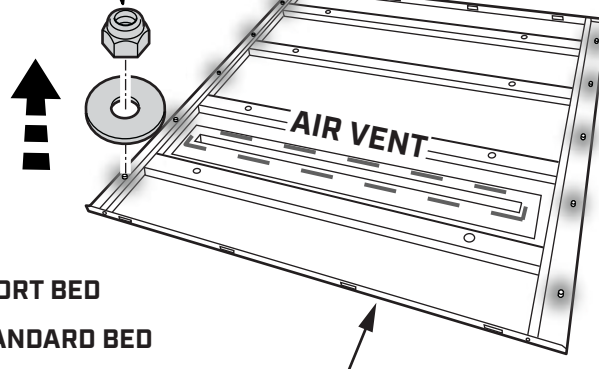
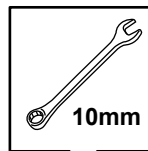

**10X** SHORT BED

**12X** STANDARD BED

**ROOF PANEL**

**I-SHEET-NA-S2**

# STEP 4

LOCATE THE RIGHT PANEL IN THE SMARTCAP PACKAGE AND BRING IT TO YOUR WORK AREA.

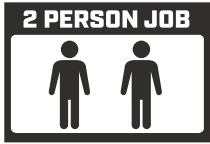

**THE SLANTED EDGE INDICATES REAR**

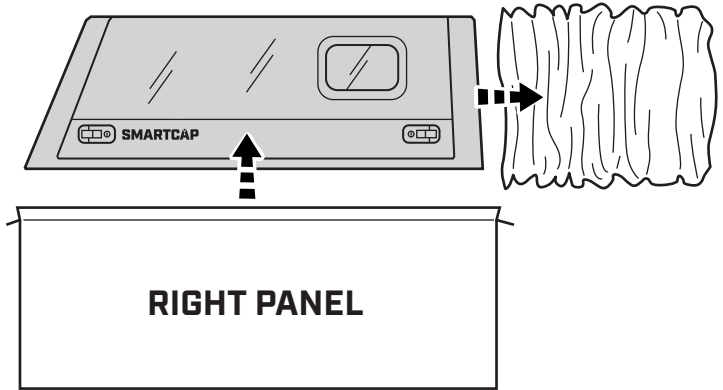
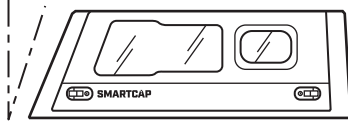

# STEP 5

INSERT PANEL TABS INTO NARROW SLOTS JUST ABOVE FOAM PADDING ON ROOF PANEL.

TAP FIRMLY WITH PALM OF HAND UNTIL THERE IS A 2-3MM GAP.



SLANTED EDGE TOWARDS REAR

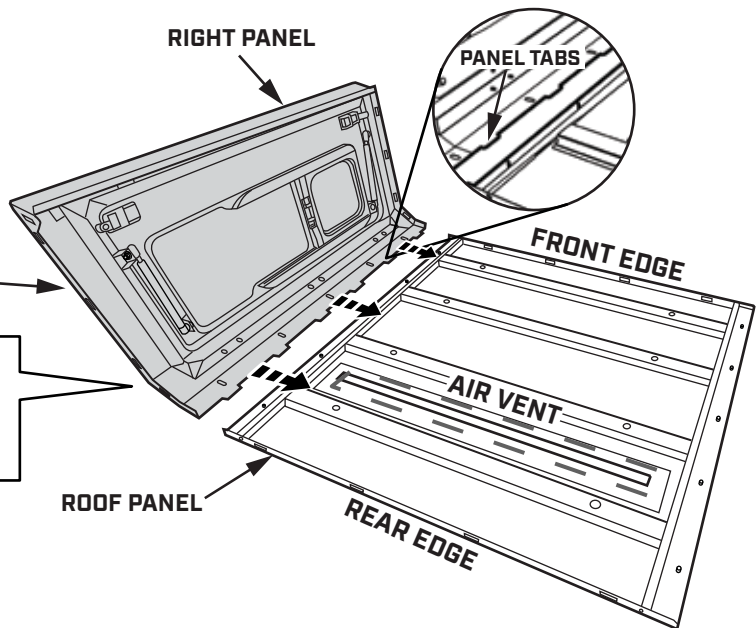
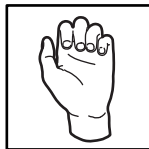

# STEP 6

HAND TIGHTEN M6 LOCK NUT WITH M6 FENDER WASHER TO ALL BOLTS.



M6 LOCK NUT

M6 FENDER WASHER

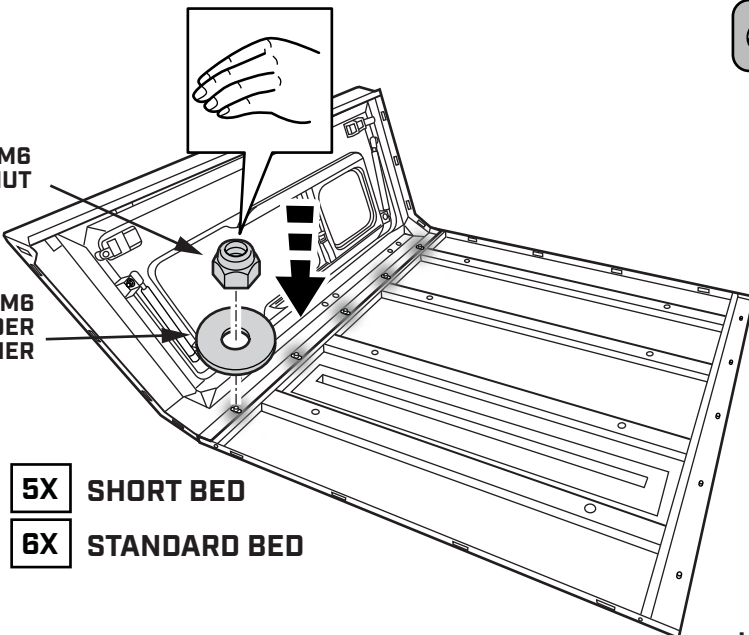

**5X** SHORT BED

**6X** STANDARD BED

I-SHEET-NA-S2

# STEP 7

LOCATE THE LEFT PANEL IN THE SMARTCAP PACKAGE AND BRING IT TO YOUR WORK AREA.

2 PERSON JOB

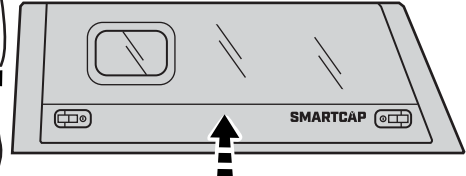
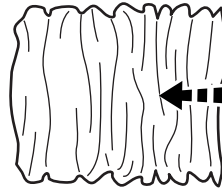
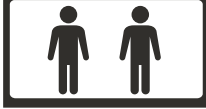

**THE SLANTED EDGE INDICATES REAR**

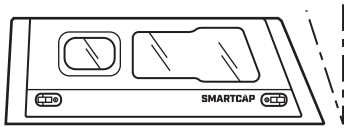

LEFT PANEL

# STEP 8

INSERT PANEL TABS INTO NARROW SLOTS JUST ABOVE FOAM PADDING ON ROOF PANEL.

TAP FIRMLY WITH PALM OF HAND UNTIL THERE IS A 2-3MM GAP.

2 PERSON JOB

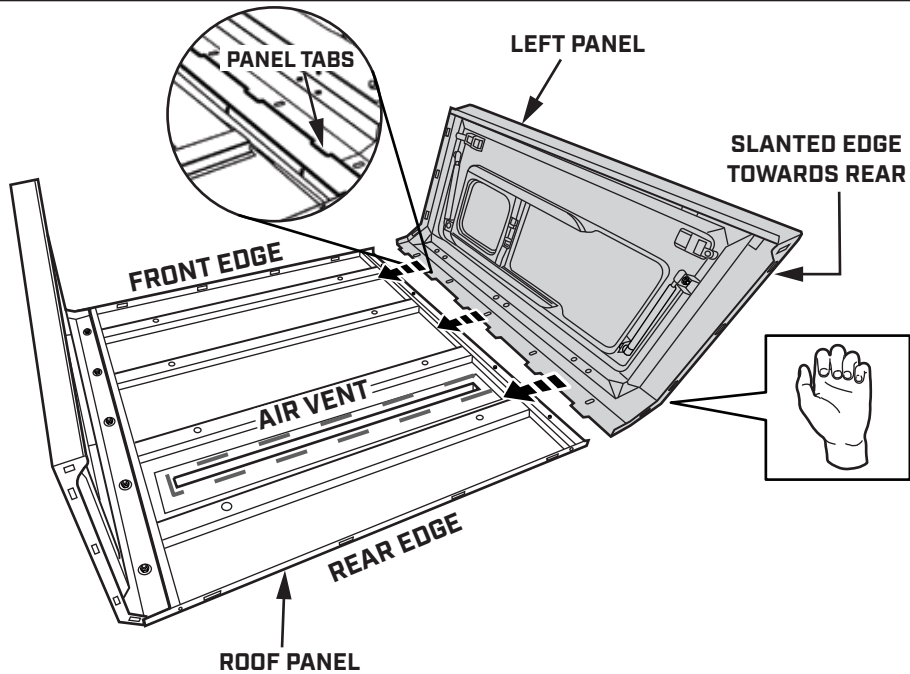

# STEP 9

HAND TIGHTEN M6 LOCK NUT WITH M6 FENDER WASHER TO ALL BOLTS.

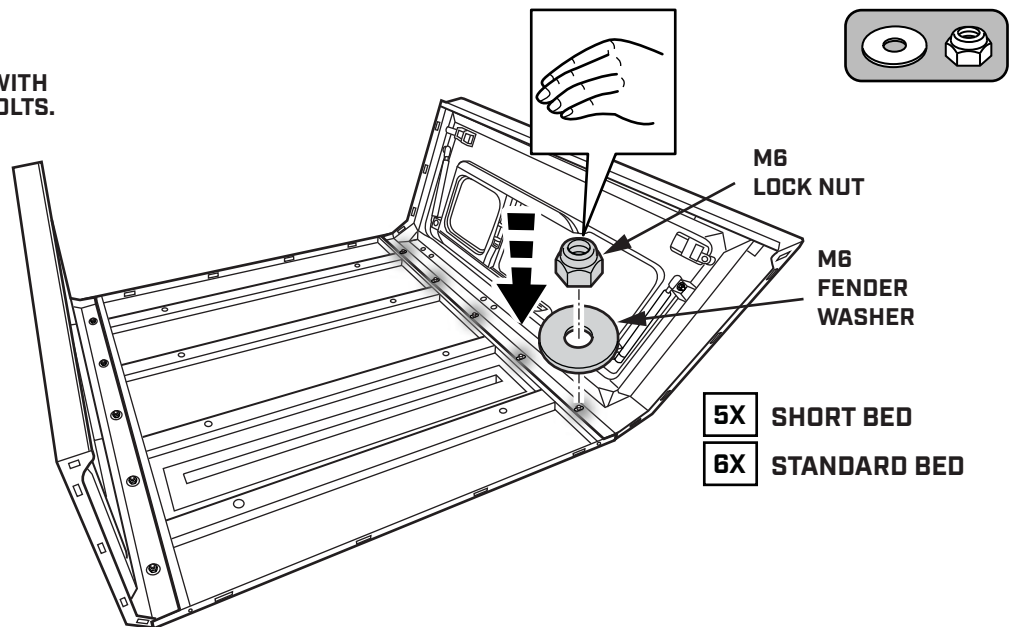

I-SHEET-NA-S2

# STEP 10

PUSH THE SMARTCAP TO EXPOSE A FEW INCHES OF STYRAFOAM UNDERNEATH THE ROOF PANEL TO PROVIDE SUPPORT FOR THE FRONT FLANGE.

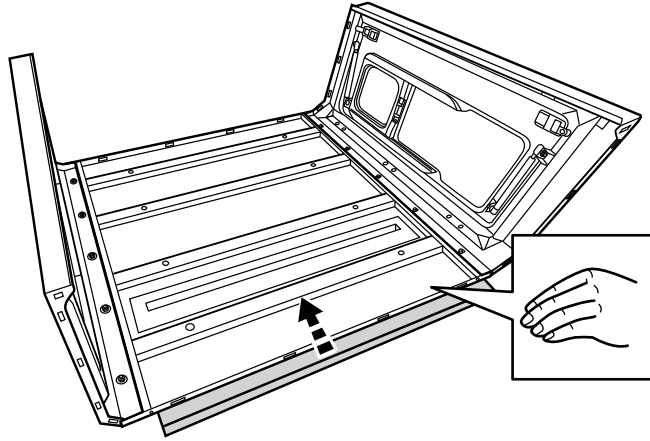

# STEP 11

LOCATE THE FRONT FLANGE IN THE SMARTCAP PACKAGE AND BRING IT TO YOUR WORK AREA.

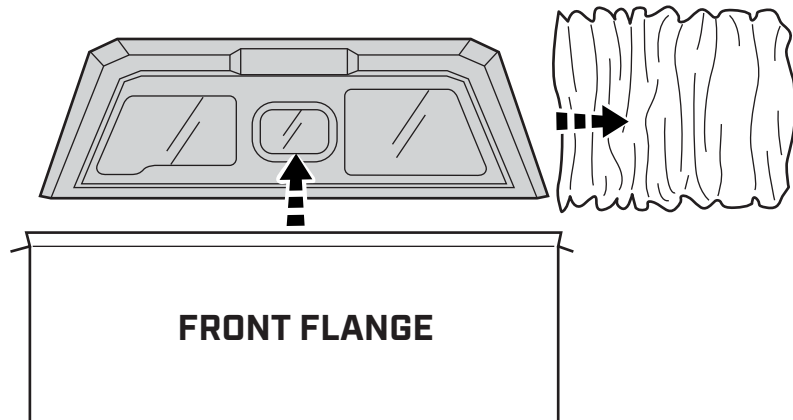

FRONT FLANGE

# STEP 12

USE A 10MM COMBINATION WRENCH TO REMOVE ALL HARDWARE FROM THE FRONT FLANGE AND SAVE FOR REUSE



REFER TO PG. 3 TO DETERMINE IF YOU HAVE VERSION A OR B

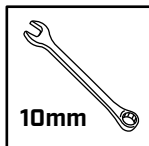
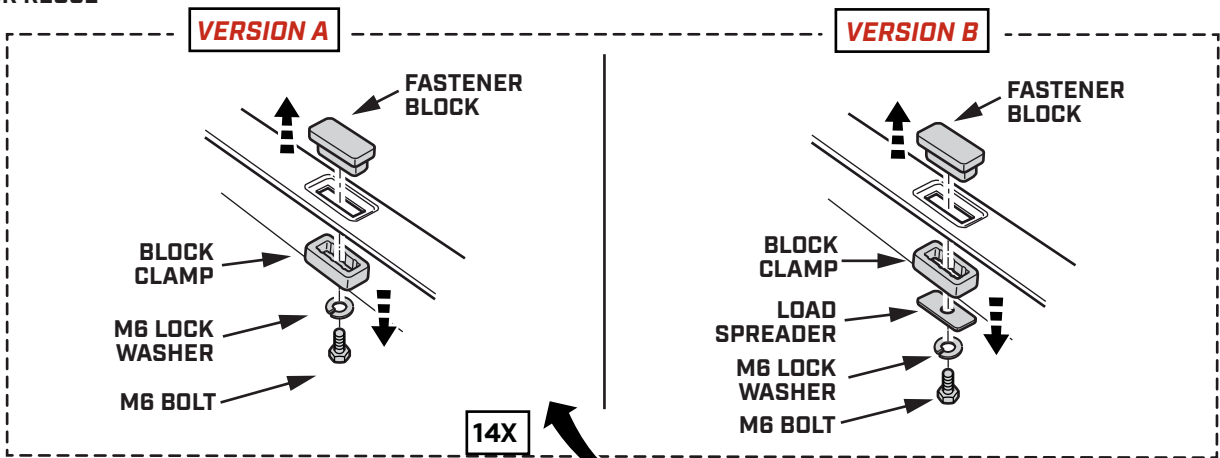

10mm

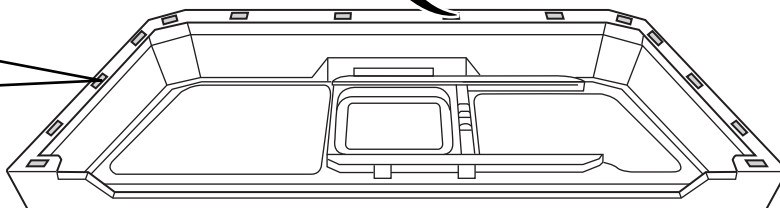

# STEP 13

PLACE FRONT FLANGE AS SHOWN.

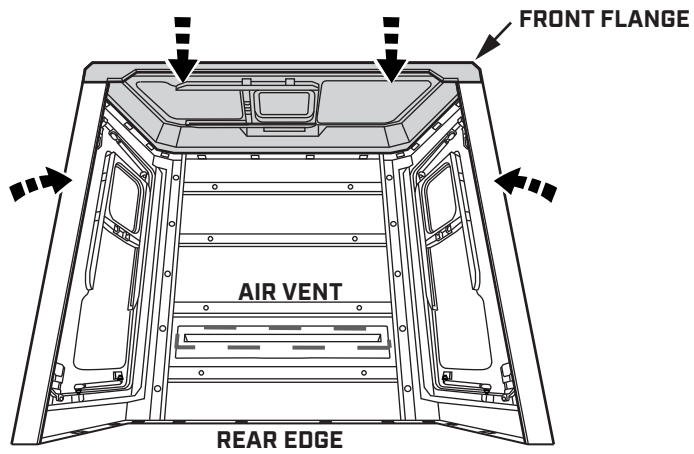

# STEP 14

INSTALL HARDWARE ALONG FRONT FLANGE WITH M6 BOLT ON INSIDE.

START WITH ASSEMBLING FASTENER BLOCKS 1-5.

ADJUST LEFT AND RIGHT PANELS TO ALIGN FASTENER BLOCKS 6-15 FOR ASSEMBLY.

HAND TIGHTEN IN THE SEQUENCE SHOWN.



**REFER TO PG. 3 TO DETERMINE IF YOU HAVE VERSION A OR B**

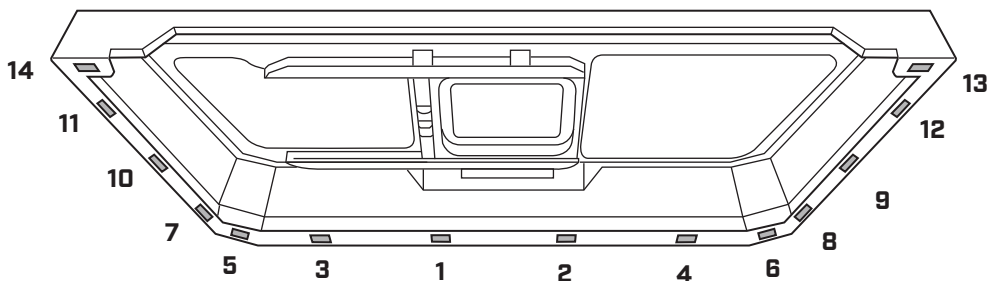
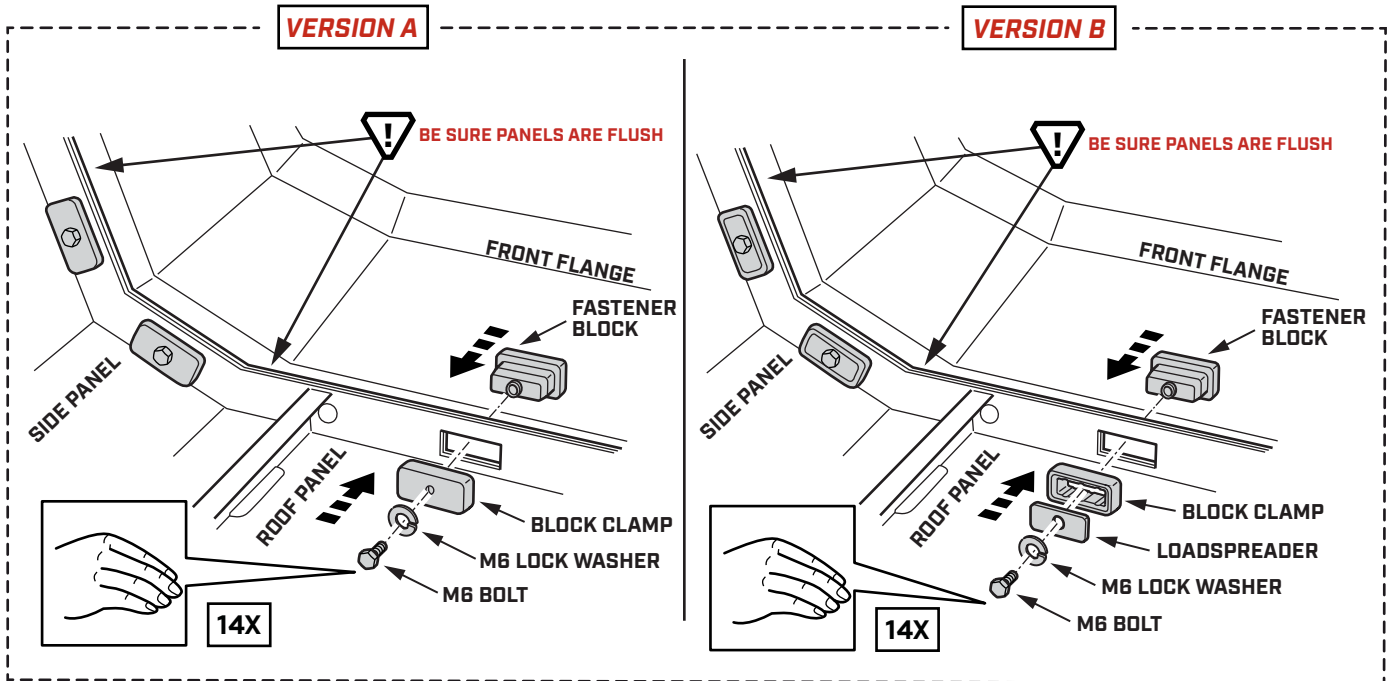

FOLLOW THE TIGHTENING SEQUENCE 1-14

I-SHEET-NA-S2



## STEP 15

PUSH THE SMARTCAP TO EXPOSE A FEW INCHES OF STYRAFOAM UNDERNEATH THE ROOF PANEL TO PROVIDE SUPPORT FOR THE REAR FLANGE.

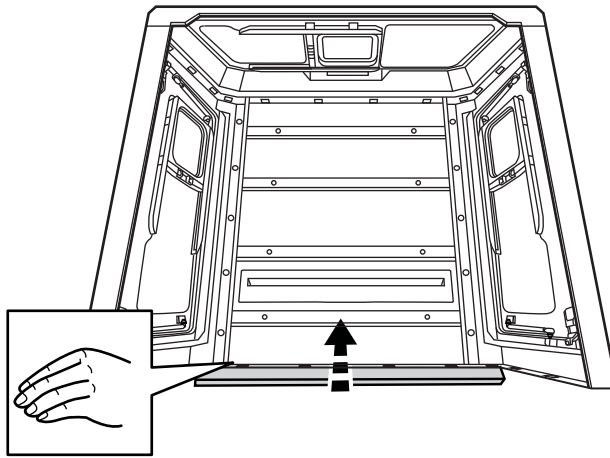

## STEP 16

LOCATE THE REAR FLANGE IN THE SMARTCAP PACKAGE AND BRING IT TO YOUR WORK AREA.

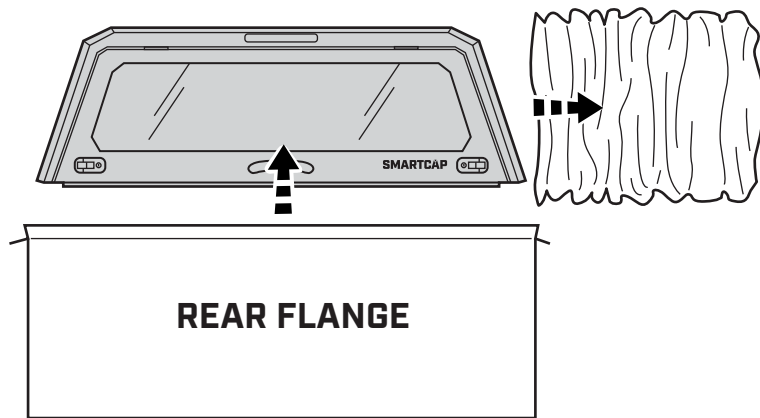

## STEP 17

USE A 10MM COMBINATION WRENCH TO REMOVE ALL HARDWARE FROM THE FRONT FLANGE AND SAVE FOR REUSE.



**REFER TO PG. 3 TO DETERMINE IF YOU HAVE VERSION A OR B**

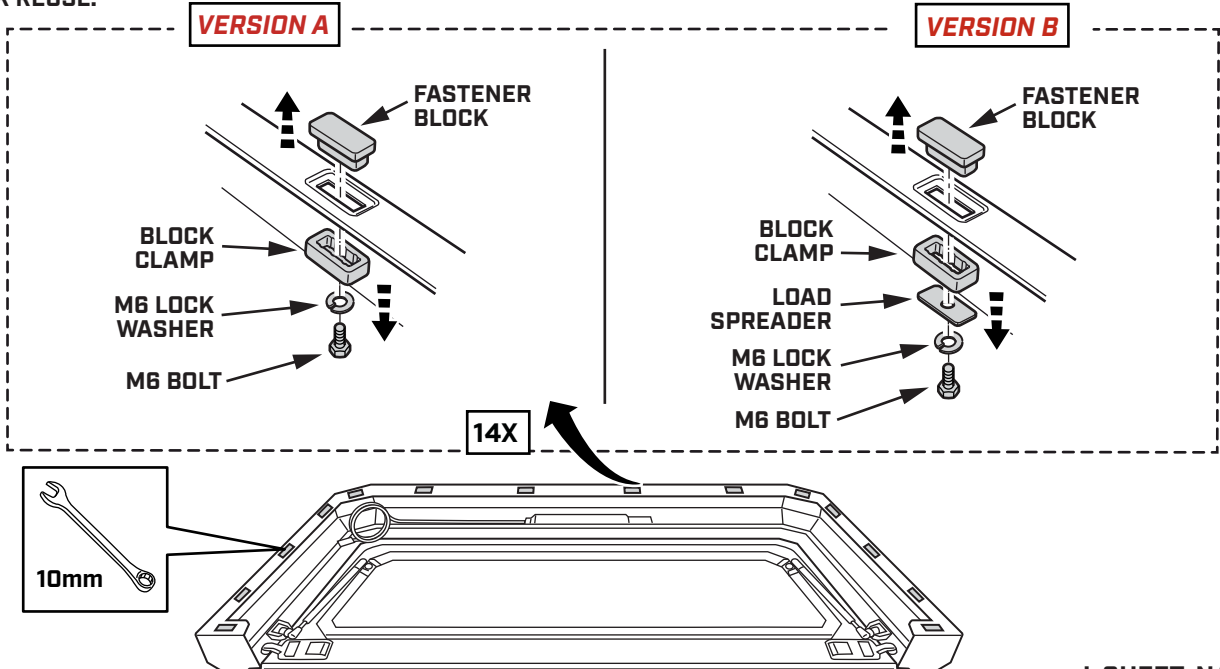

I-SHEET-NA-S2

# STEP 18

PLACE REAR FLANGE AS SHOWN.

2 PERSON JOB

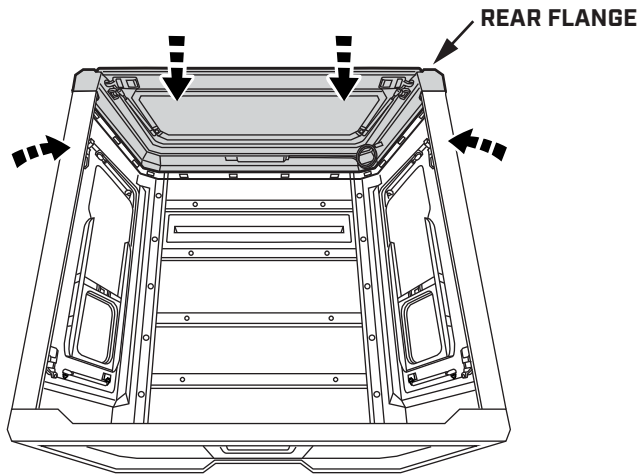

# STEP 19

INSTALL HARDWARE ALONG FRONT FLANGE WITH M6 BOLT ON INSIDE.

START WITH ASSEMBLING FASTENER BLOCKS 1-5.

ADJUST LEFT AND RIGHT PANELS TO ALIGN FASTENER BLOCKS 6-15 FOR ASSEMBLY.

HAND TIGHTEN IN THE SEQUENCE SHOWN.

2 PERSON JOB



REFER TO PG. 3 TO DETERMINE IF YOU HAVE VERSION A OR B

VERSION A

VERSION B

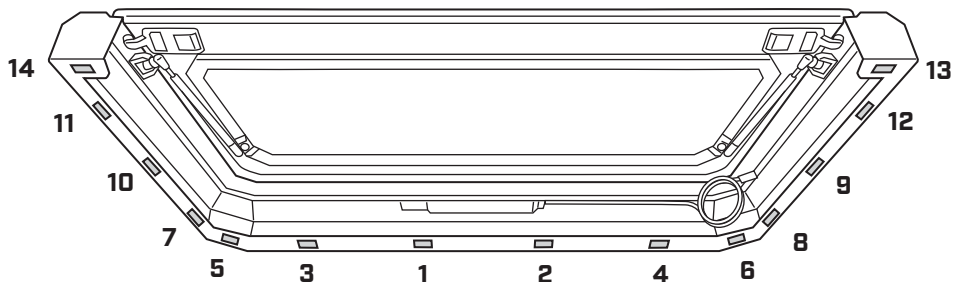
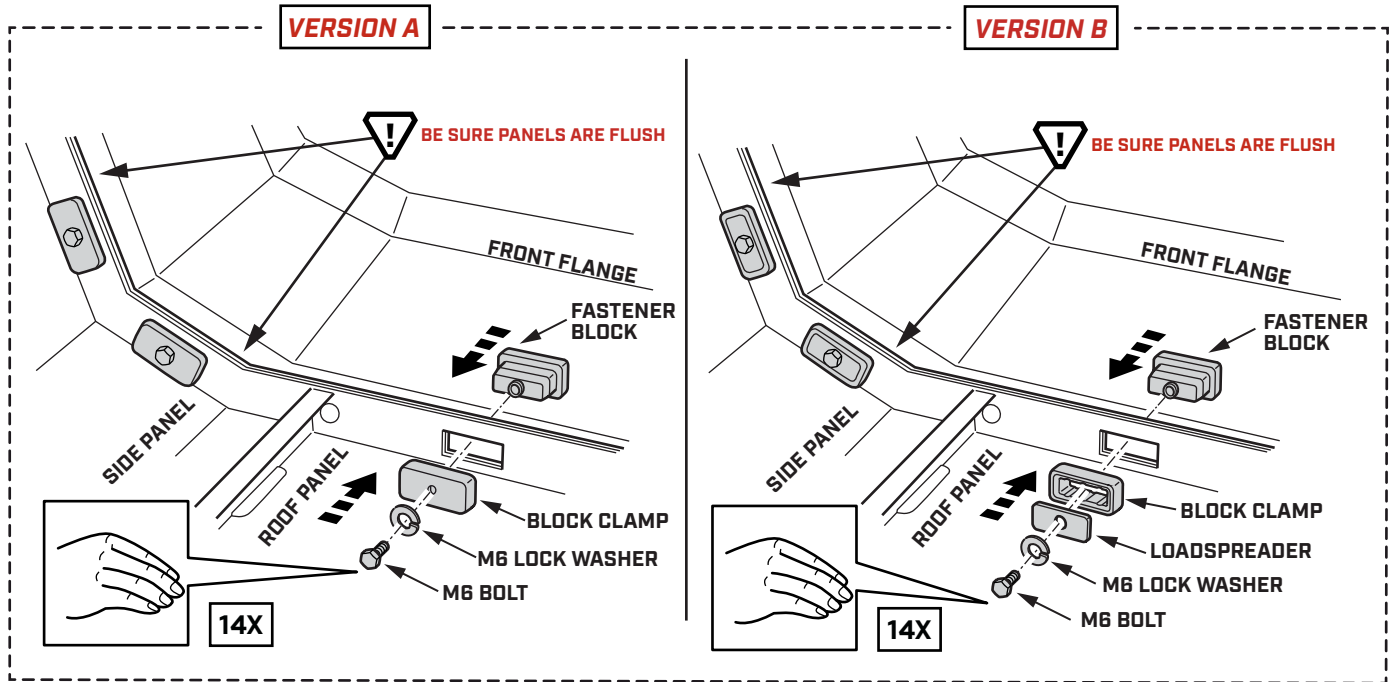

FOLLOW THE TIGHTENING SEQUENCE 1-14

I-SHEET-NA-S2

# STEP 20

TIGHTEN ALL HARDWARE WITH TORQUE WRENCH AND 10MM SOCKET TO 3.7 FT. LBS. (5 NEWTON METERS)

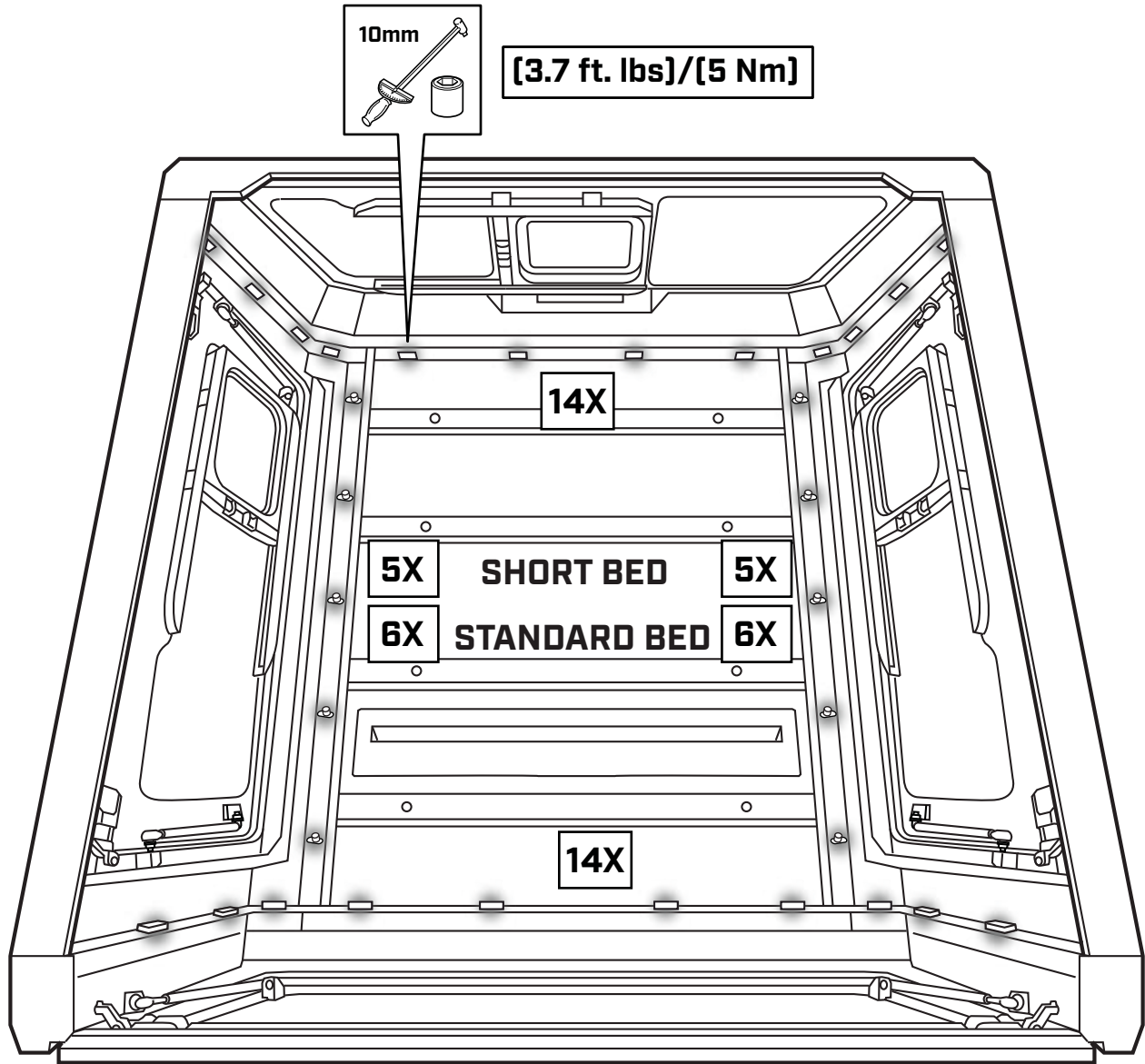

# STEP 21



**REFER TO PG. 3 TO DETERMINE IF YOU HAVE VERSION A OR B**

## VERSION A

- A** LOCATE THE D-RUBBER RETENTION TAB NEXT TO THE REAR DOOR GASKET.  
BEND THE TAB UPWARDS AT A 45 DEGREE ANGLE.

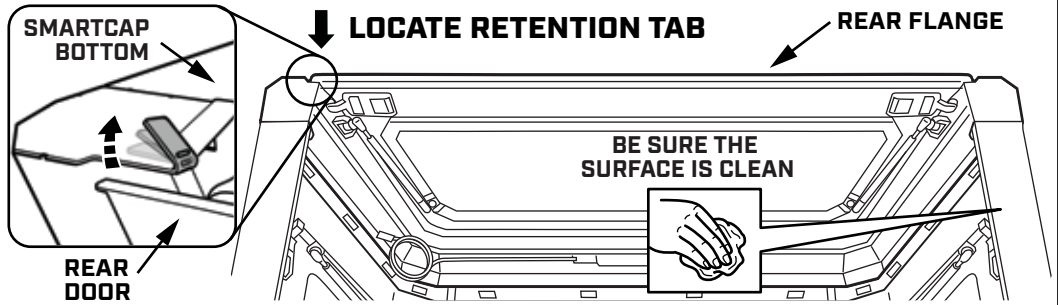

- B** PEEL AWAY A SMALL PORTION OF THE ADHESIVE BACKING FROM THE D-RUBBER.

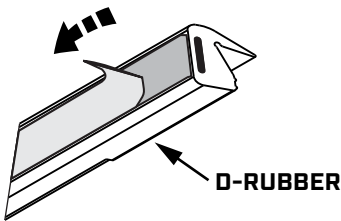

- C** INSERT THE TAB INTO THE D-RUBBER UNTIL THE D-RUBBER LIGHTLY BUTTS UP AGAINST REAR DOOR GASKET.

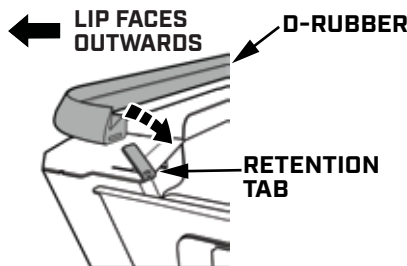

- D** FIRMLY PUSH THE TAB BACK DOWN TO SECURE THE D-RUBBER IN PLACE.

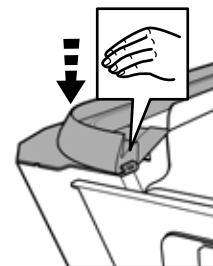

### CORRECT D-RUBBER ORIENTATION

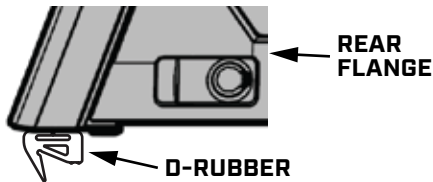

### INCORRECT D-RUBBER ORIENTATION

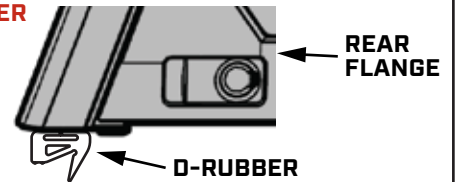

## VERSION B

- APPLY D-RUBBER TO BOTTOM OF SMARTCAP WITH END LIGHTLY BUTTED AGAINST THE REAR DOOR GASKET.

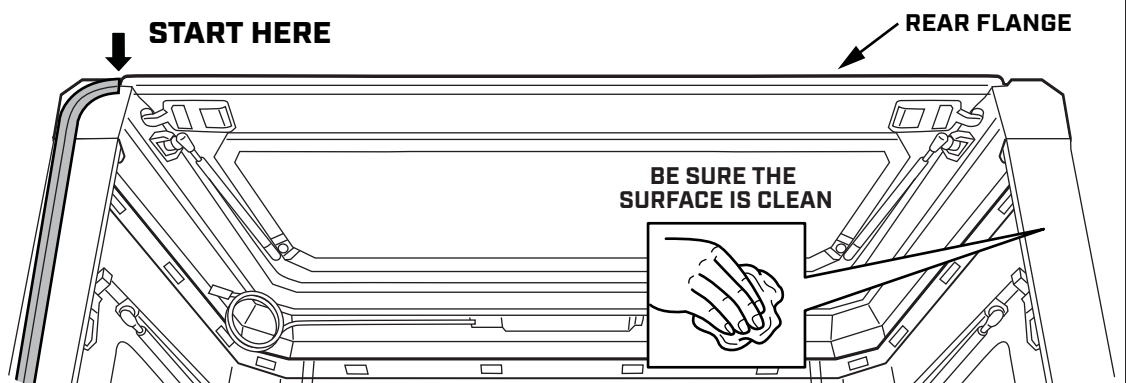

- A** POSITION THE D-RUBBER ALONG THE OUTSIDE EDGE OF THE SMARTCAP.

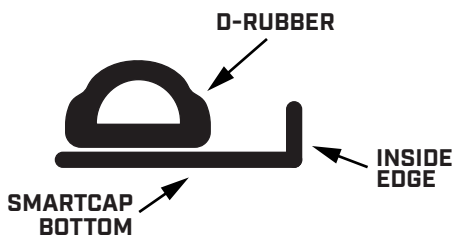

- B** PEEL ADHESIVE BACKING IN SMALL LENGTHS AS YOU WORK AROUND THE SMARTCAP.

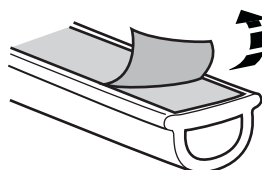

- C** STAY WITHIN 1/8 INCH FROM THE SMARTCAP'S OUTER EDGES.

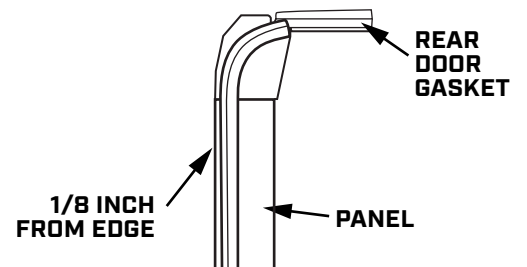

I-SHEET-NA-S2

# STEP 22



**REFER TO PG. 3 TO DETERMINE  
IF YOU HAVE VERSION A OR B**

## VERSION A

PEEL AWAY ADHESIVE BACKING  
IN SHORT LENGTHS AS YOU  
WORK AROUND THE EDGES.

STAY WITHIN 1/8 INCH  
FROM THE SMARTCAP'S  
OUTER EDGES.

REMOVE EXCESS  
WITH A STRAIGHT CUT.

1/8 INCH  
FROM EDGE

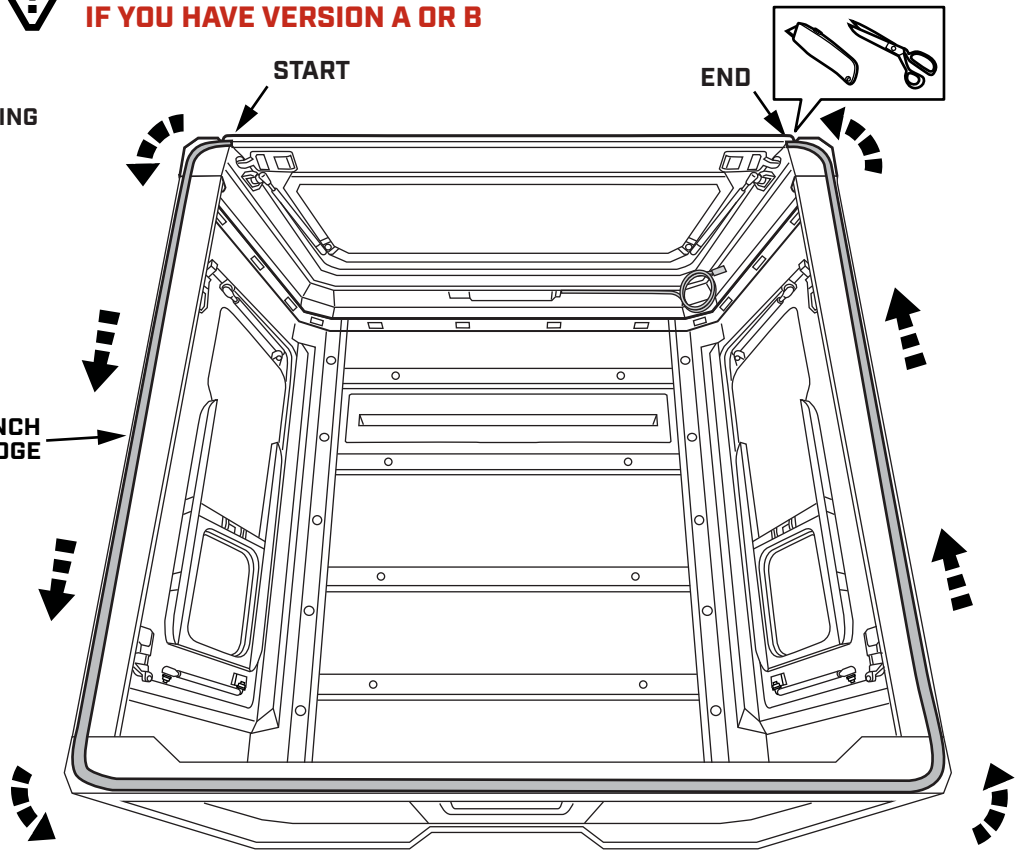

## VERSION B

REMOVE EXCESS  
WITH A STRAIGHT CUT.

REINFORCE THE ENDS  
OF THE D-RUBBER  
WITH SUPERGLUE.

1/8 INCH  
FROM EDGE

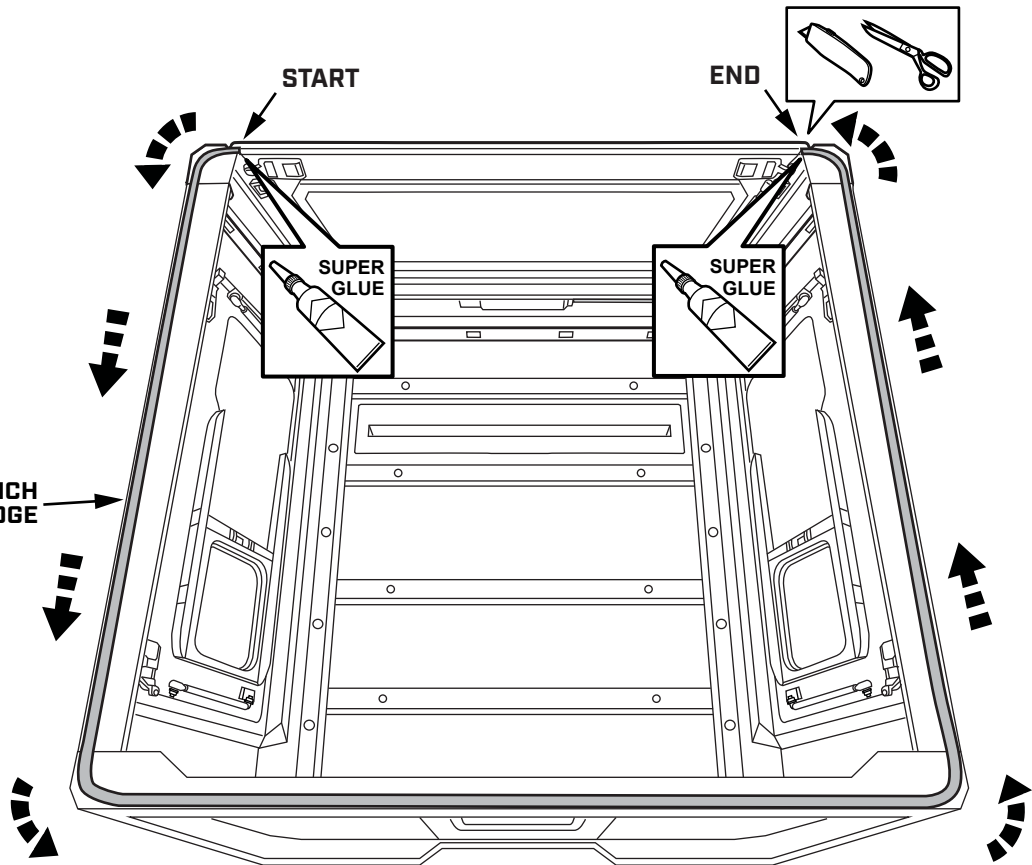

I-SHEET-NA-S2

## INSTALLATION HARDWARE

### THIN RUBBER PAD

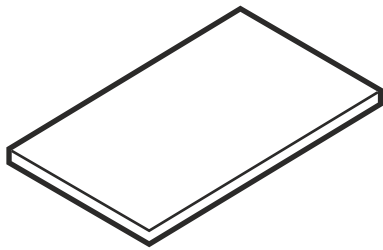

6X

### MOUNTING CLAMP

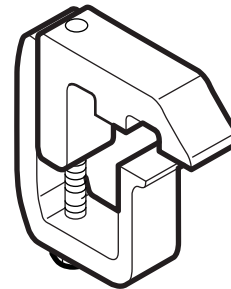

6X

### THICK RUBBER PAD

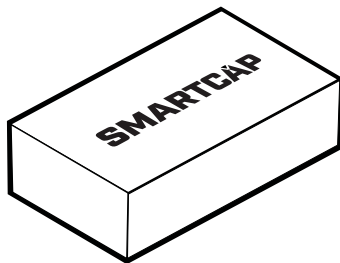

8X

### FOAM SEAL TAPE

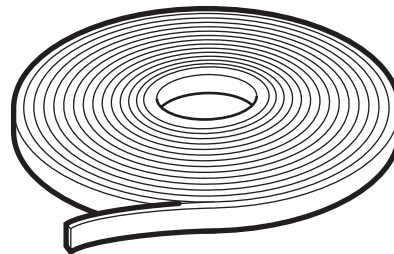

1X

## VEHICLE INSTALLATION



### IMPORTANT

- ▼ ASSISTANCE WILL BE NEEDED FOR THIS INSTALLATION. FOUR PEOPLE ARE RECOMMENDED TO LIFT THE SMARTCAP ONTO THE VEHICLE.
- ▼ AVOID PINCHING OR CRUSHING HANDS AND FINGERS.
- ▼ READ THROUGH THE ENTIRE PROCEDURE BEFORE STARTING.

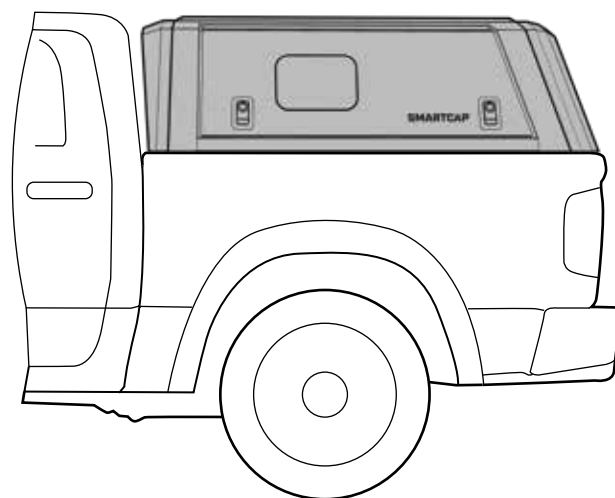

I-SHEET-NA-S2

# STEP 23

REMOVE THE ADHESIVE BACKING FROM THE THICK RUBBER PAD.

PLACE THE PADS ALONG THE INSIDE OF THE D-RUBBER AT THE INDICATED LOCATIONS.

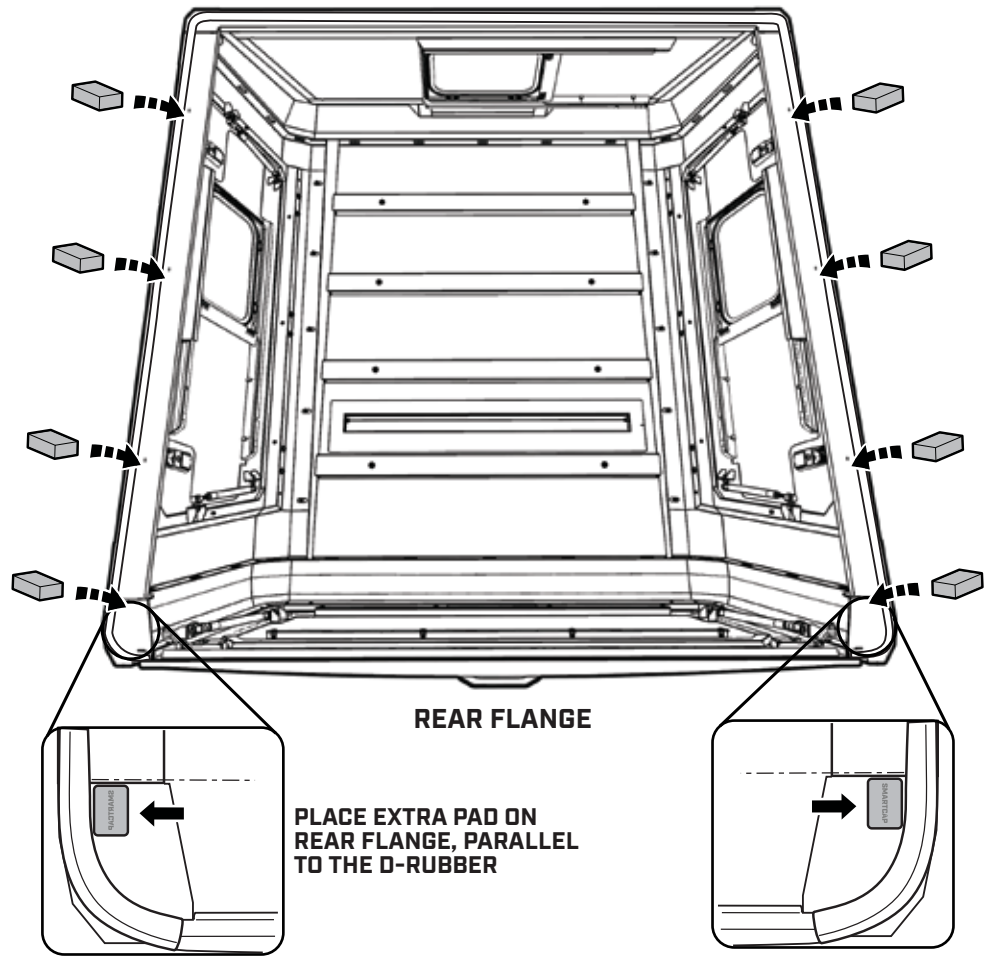
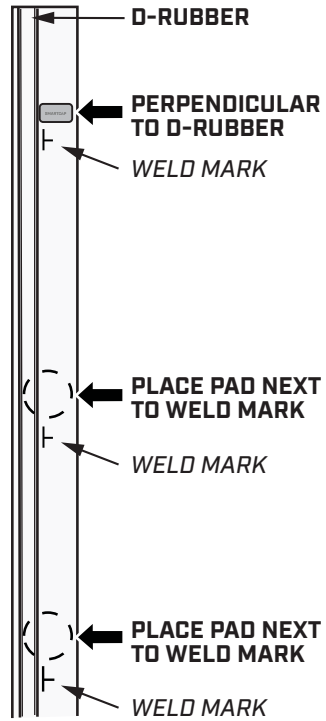

# STEP 24

INSPECT THE TRUCK BED. IF FRONT EDGE IS LOWER THAN THE SIDES, ADD FOAM SEAL TAPE TO THE FRONT EDGE OF THE BED.

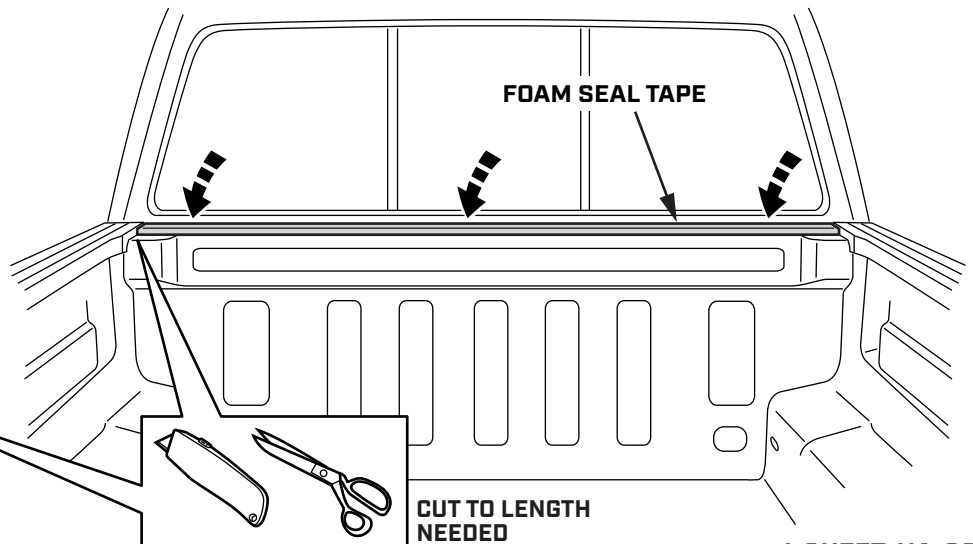
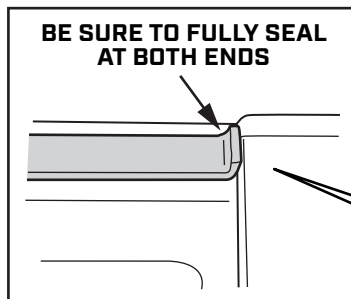
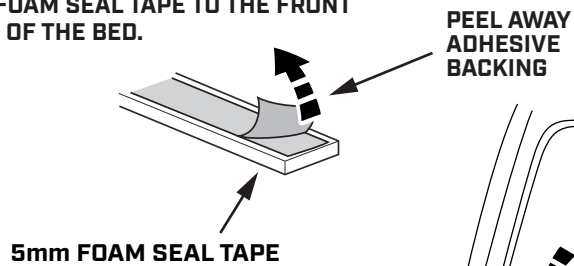
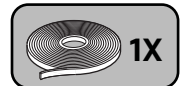

I-SHEET-NA-S2



## STEP 25

USE 4 PEOPLE TO LIFT THE ASSEMBLED SMARTCAP ONTO THE TRUCK BED.

TO AVOID DAMAGE TO THE D-RUBBER, DO NOT SLIDE THE SMARTCAP INTO PLACE.

4 PERSON JOB

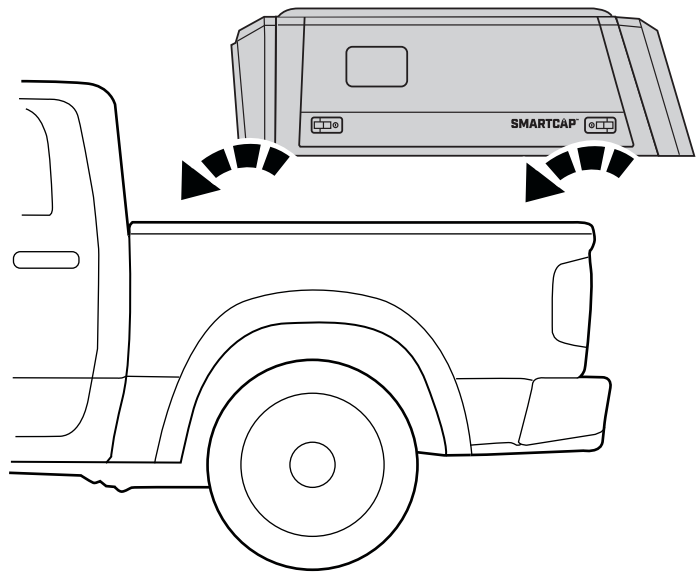

## STEP 26

CHECK THAT THE SMARTCAP IS PROPERLY POSITIONED AND CENTERED ON THE TRUCK BED.

IT'S IMPORTANT THAT THE SMARTCAP IS NOT PUSHED TOO FAR FORWARD, LEAVING A GAP BETWEEN THE SMARTCAP AND THE CAB.

4 PERSON JOB

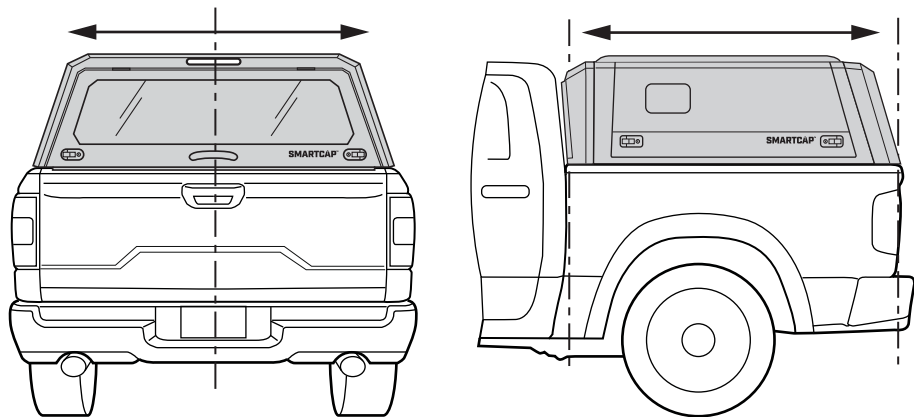

## STEP 27

WALK AROUND THE TRUCK BED TO MAKE SURE THE D-RUBBER FITMENT IS CORRECT AND THAT THE RUBBER LIP IS PROPERLY TUCKED UNDERNEATH THE CAP.

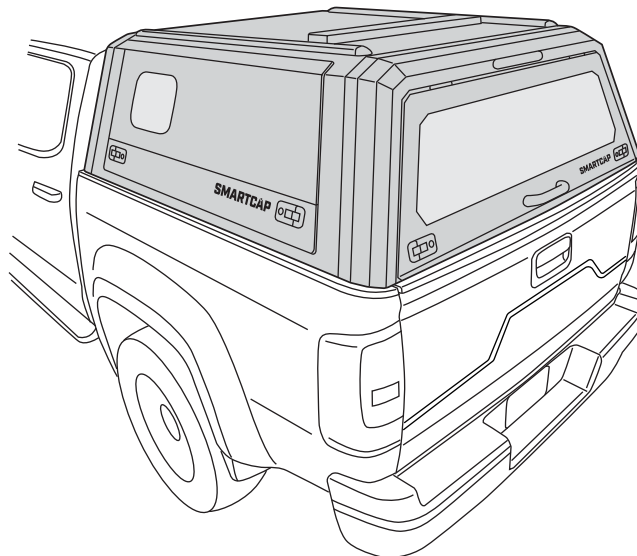

I-SHEET-NA-S2



# STEP 28

IN ORDER TO ENSURE CORRECT COMPRESSION OF THE D-RUBBER, YOU MUST TRIM TWO 1" INCH STRIPS FROM TWO DIFFERENT THIN RUBBER PADS.

WHILE LIFTING UP ON THE CAP, PLACE 1 STRIP IN EACH REAR CORNER OF THE CAP, IN BETWEEN THE THICK RUBBER PAD AND THE TRUCK BED RAILING.

**REPEAT FOR EACH SIDE**

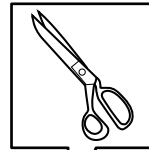

TRIM A 1" INCH STRIP FROM THIN RUBBER PAD.

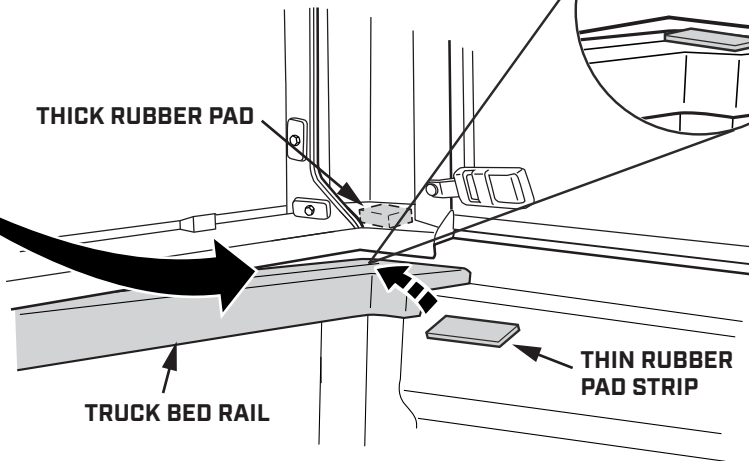
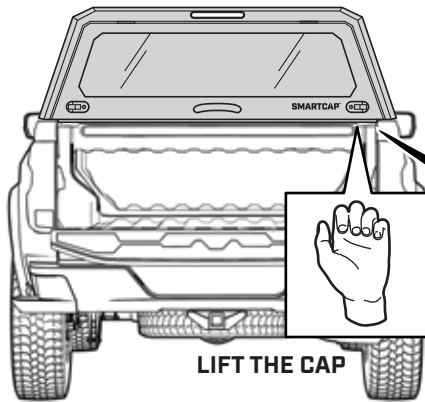
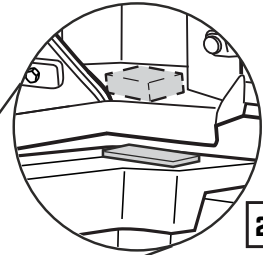
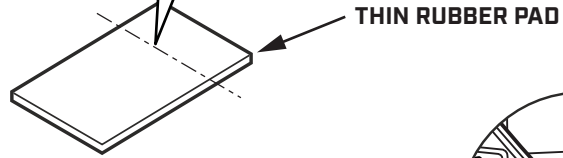

# STEP 29

CHECK THE OPERATION OF THE TAILGATE. THE LIP OF THE D-RUBBER SHOULD RUB THE TAILGATE WHEN OPENING AND CLOSING WITH EASE.

THERE SHOULD BE 1/2 INCH OF SPACE BETWEEN THE D-RUBBER BASE AND THE D-RUBBER LIP WHEN THE TAILGATE IS IN THE CLOSED POSITION.

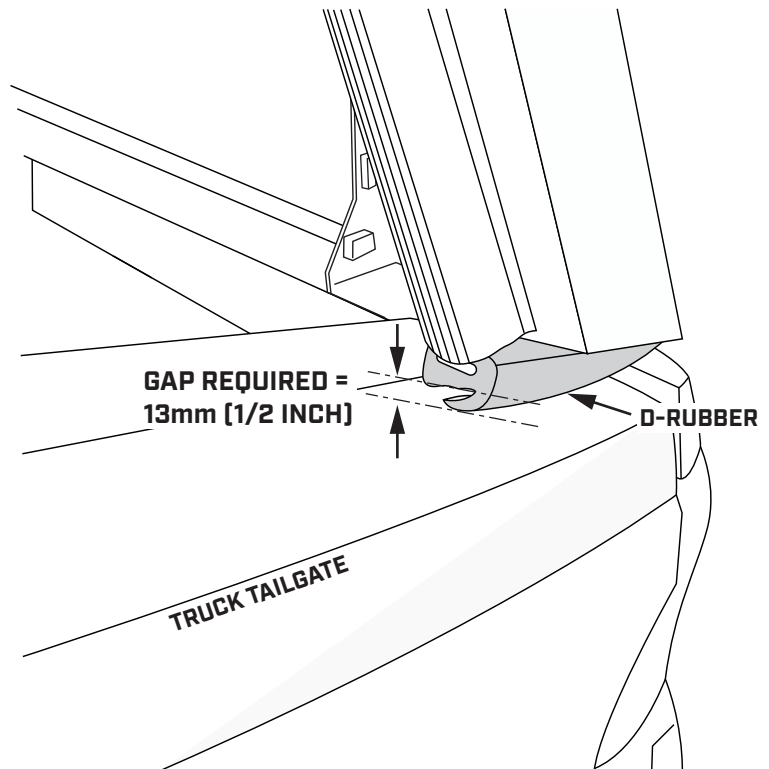

# STEP 30

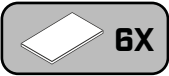

WITH THE EXCEPTION OF THE REAR CORNERS, PLACE THE THIN RUBBER PADS NEXT TO GUSSETS ON BOTH SIDES OF THE CAP.

**3 PADS PER SIDE**

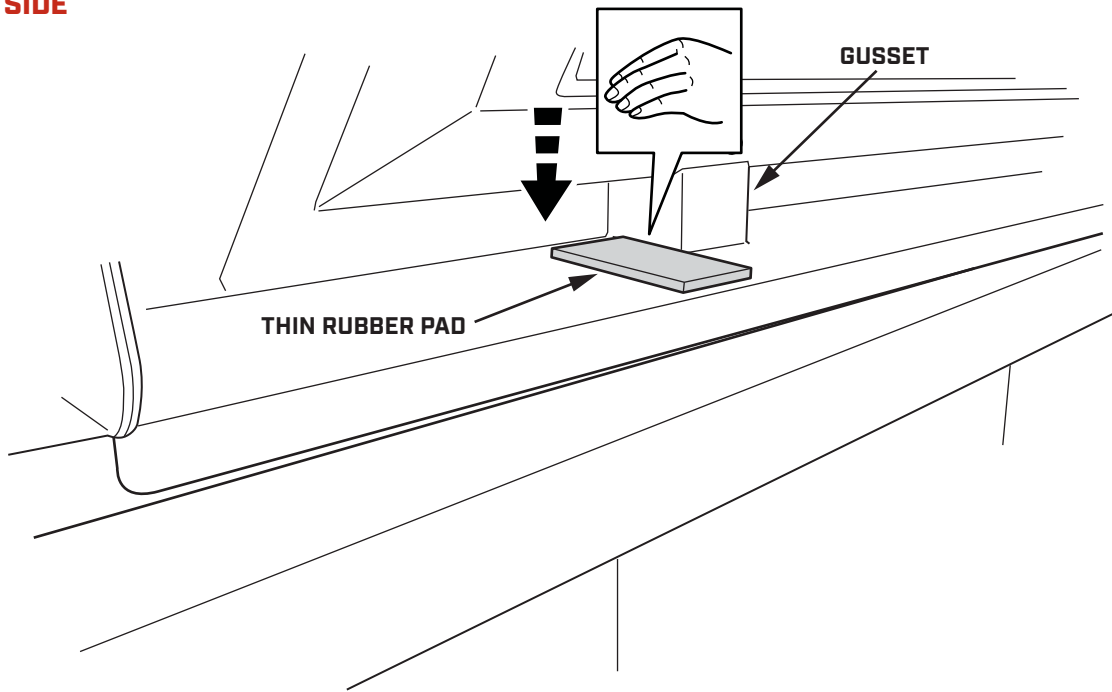

# STEP 31



ONCE ALL PADS ARE IN PLACE, INSTALL MOUNTING CLAMPS ON TOP OF THIN RUBBER PADS USING TORQUE WRENCH AND 13MM SOCKET TIGHTEN CLAMPS TO 4.4 FT. LBS. [6 NEWTON METERS]

**3 CLAMPS PER SIDE**

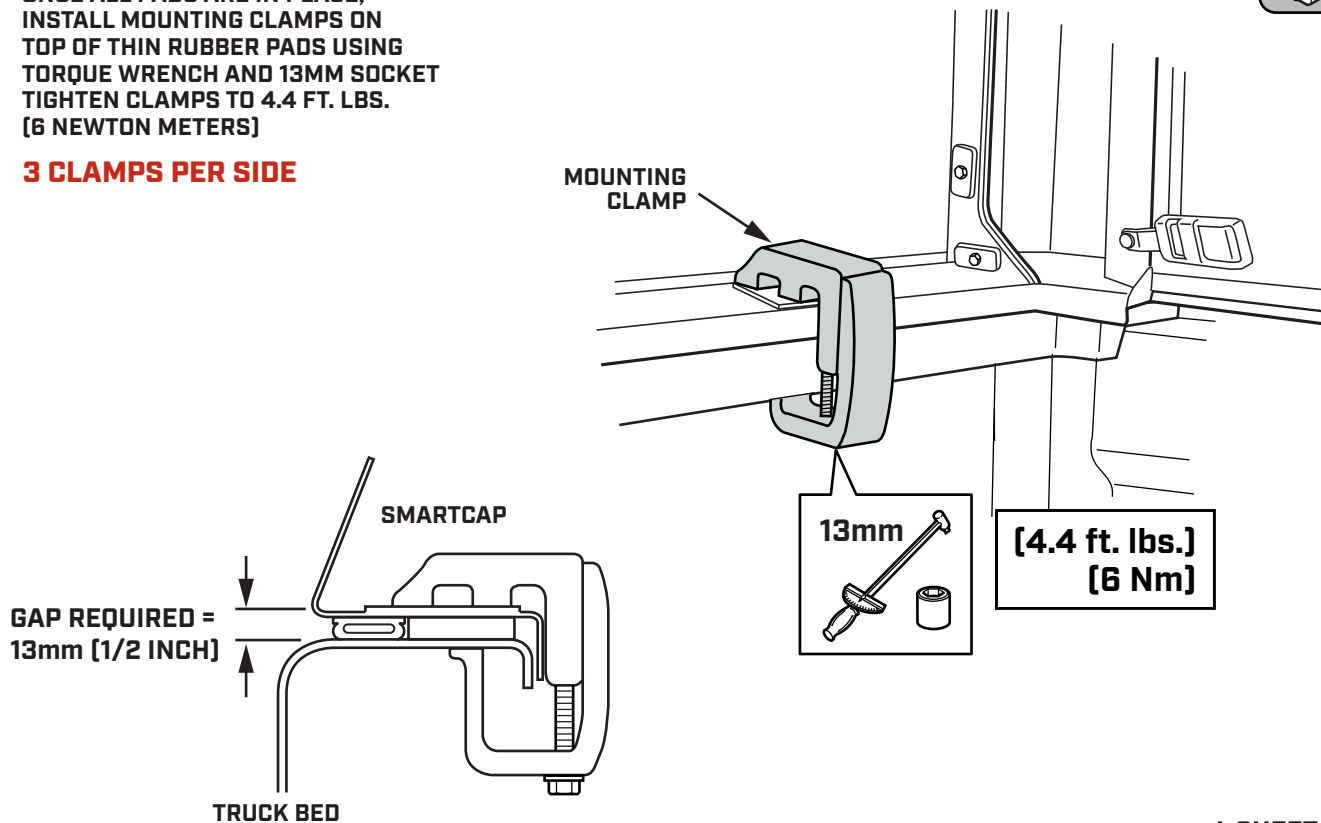

## THIRD BRAKE LIGHT INSTALLATION

### T-HARNESS

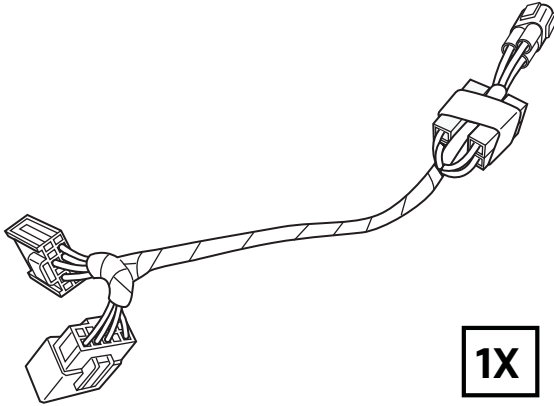

### CONNECTOR HARNESS

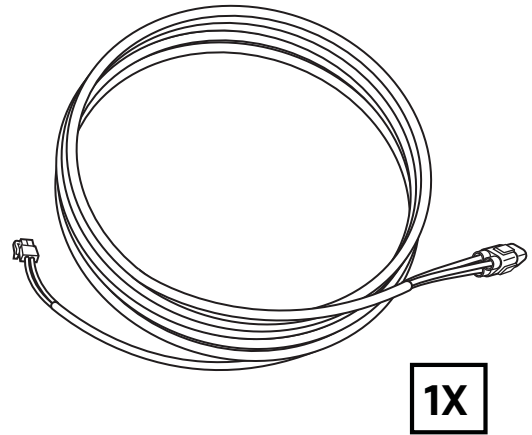

### CABLE TIE

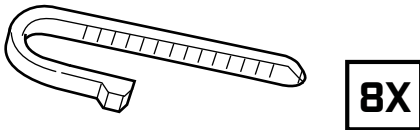

### CABLE TIE BASE

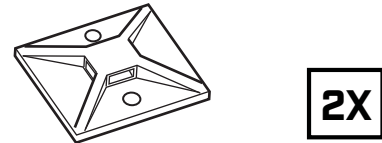

### IMPORTANT

- ▼ BE SURE THE VEHICLE IS TURNED OFF FOR THIS INSTALLATION.
- ▼ READ THROUGH THE ENTIRE PROCEDURE BEFORE STARTING AND FOLLOW THE STEPS CAREFULLY TO ENSURE THE THIRD BRAKE LIGHT WILL FUNCTION PROPERLY.
- ▼ USE A TEST LIGHT TO CHECK FOR SUCCESSFUL INSTALLATION.

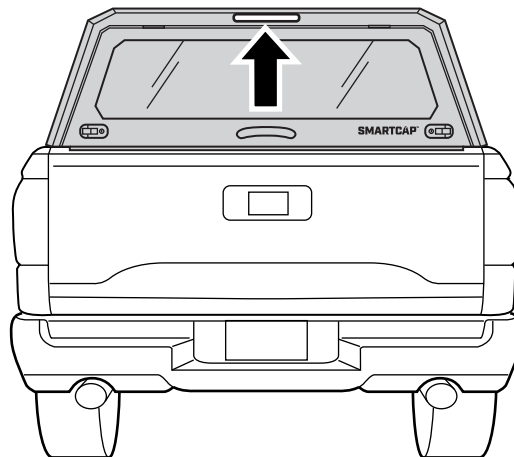

## STEP 32

BEGIN AT THE DRIVER SIDE. LOOK UNDER THE DASHBOARD AT THE FOOT WELL AND LOCATE THE GREY CONNECTOR.

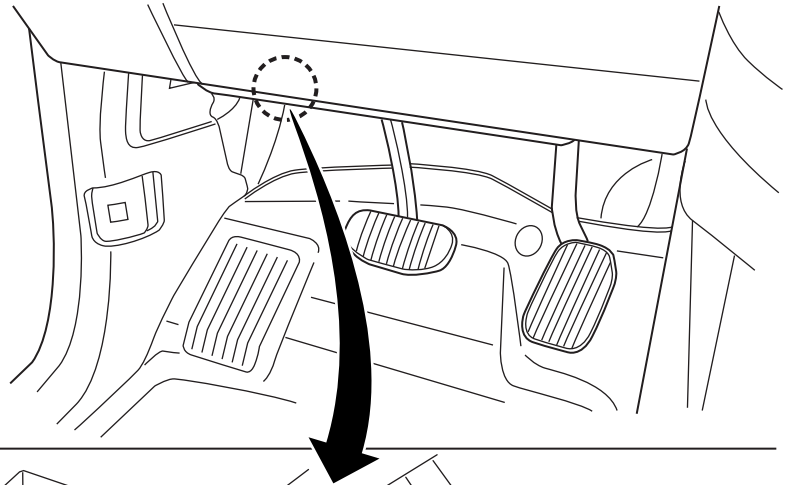

PULL THE MALE DUMMY CONNECTOR OUT FROM THE FEMALE CONNECTOR.

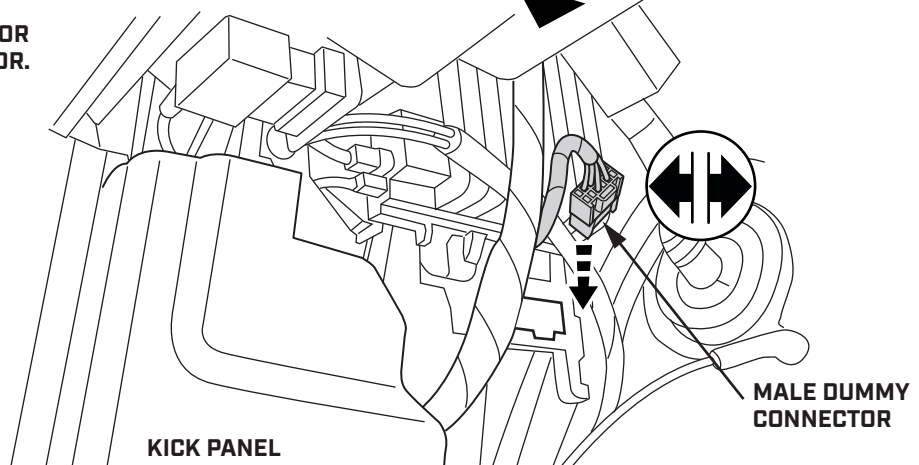

## STEP 33

PLUG THE MALE CONNECTOR FROM THE T-HARNESS INTO THE VEHICLE CONNECTOR.

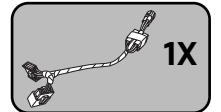
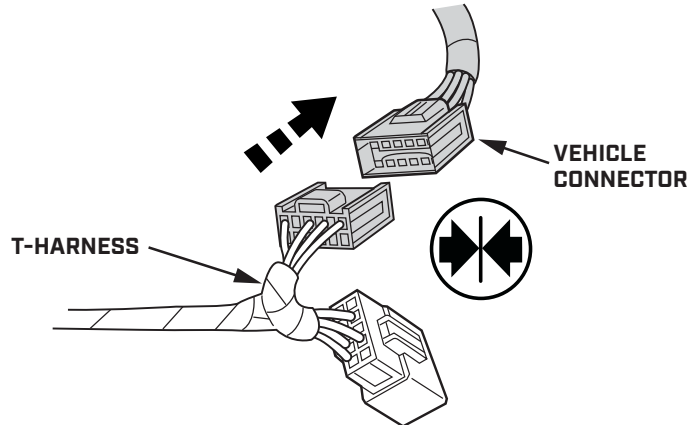

## STEP 34

PLUG THE MALE DUMMY CONNECTOR FROM THE VEHICLE CONNECTOR INTO THE T-HARNESS.

SECURE WITH A CABLE TIE AS SHOWN.

- PLUG THE MALE DUMMY CLIP FROM THE VEHICLE INTO THE T-HARNESS
- SECURE WITH A CABLE TIE AS SHOWN

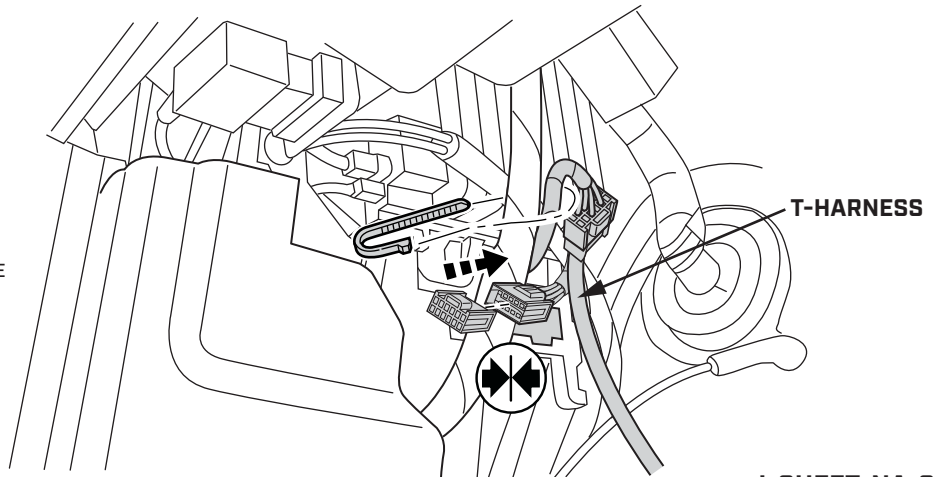

I-SHEET-NA-S2

## STEP 35

USING A PLASTIC PRY TOOL, CAREFULLY PRY OFF THE DOOR SILL TRIM PLATE ON THE DRIVER SIDE

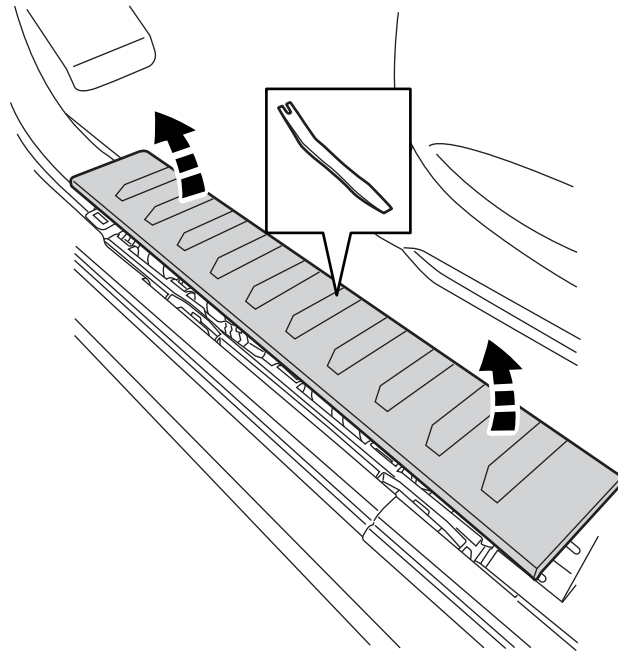

## STEP 36

UNDER THE DRIVER SIDE DASH, LOCATE THE 3-PIN PLUG OF THE T-HARNESS.

PLUG THE CONNECTOR HARNESS INTO THE 3-PIN PLUG OF THE T-HARNESS.

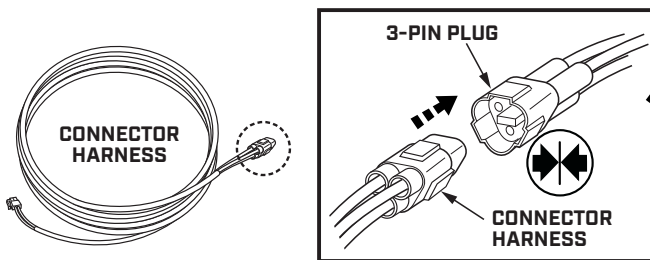

## STEP 37

TUCK THE HARNESSES UNDER THE EDGE OF THE OUTER FOOT WELL KICK PANEL AND ROUTE DOWN TOWARDS THE DOOR SILL.

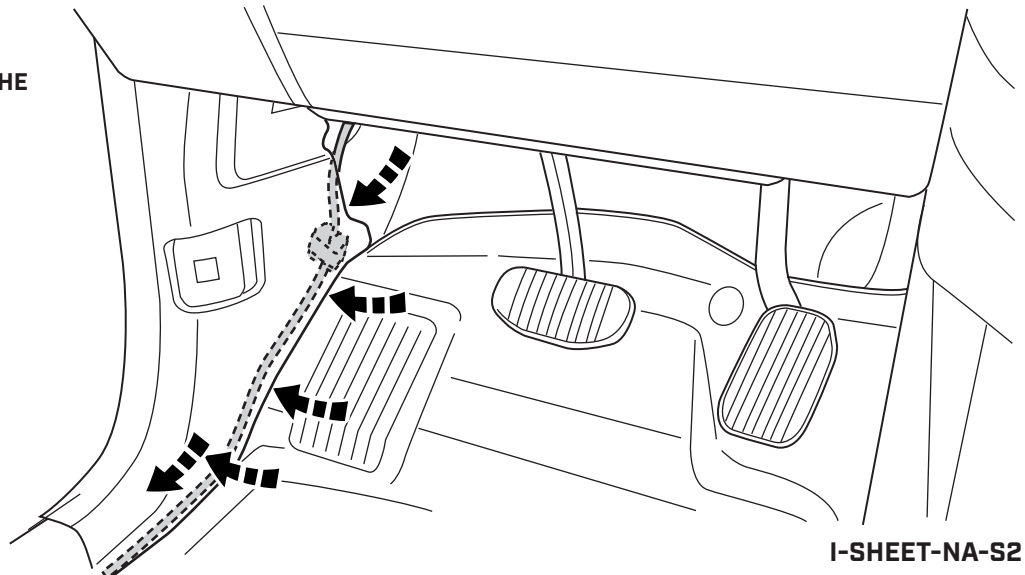

I-SHEET-NA-S2

## STEP 38

UNDERNEATH THE CARPET LINER, THERE WILL BE A RUBBER GROMMET IN THE METAL FLOOR.

LOCATE THIS GROMMET FROM UNDERNEATH THE VEHICLE.

IF NEEDED, DRILL OR CUT A SMALL OPENING THROUGH THE RUBBER GROMMET.

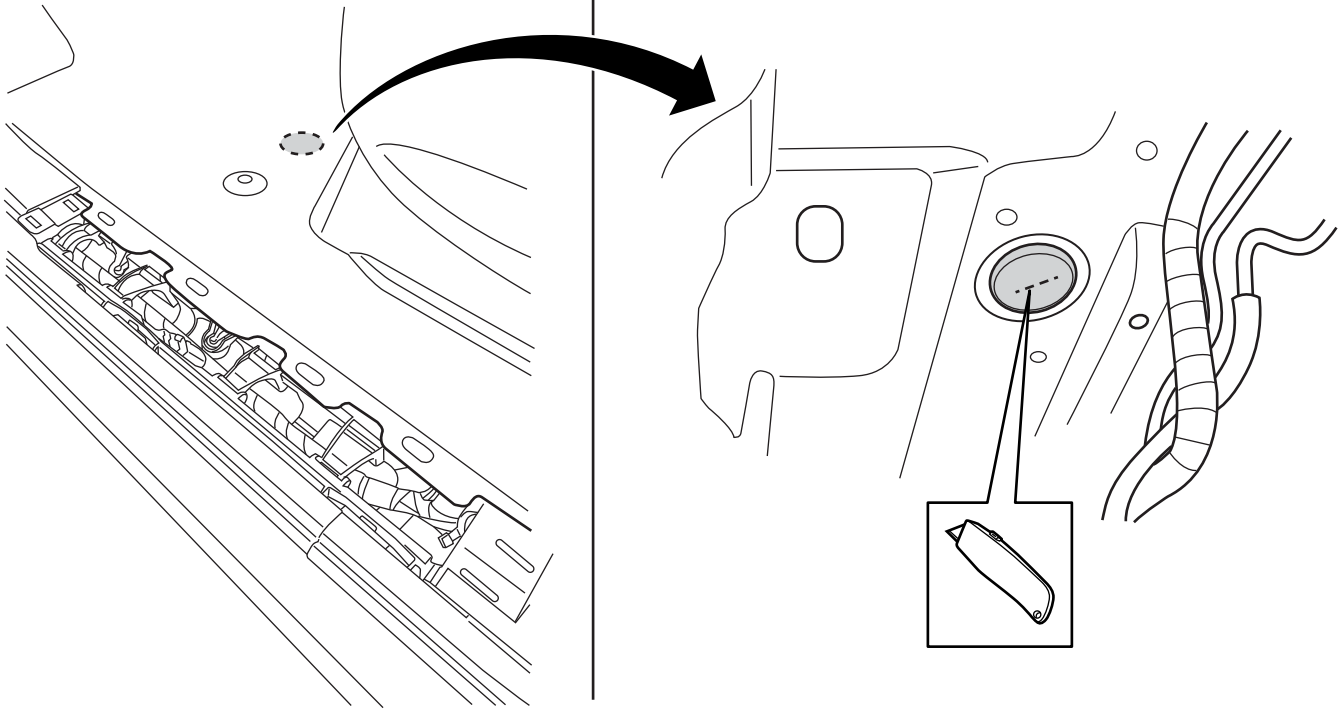

## STEP 39

ROUTE THE 2-PIN PLUG AT THE END OF CONNECTOR HARNESS UNDERNEATH THE CARPET LINER AND THROUGH THE OPENING IN THE GROMMET.

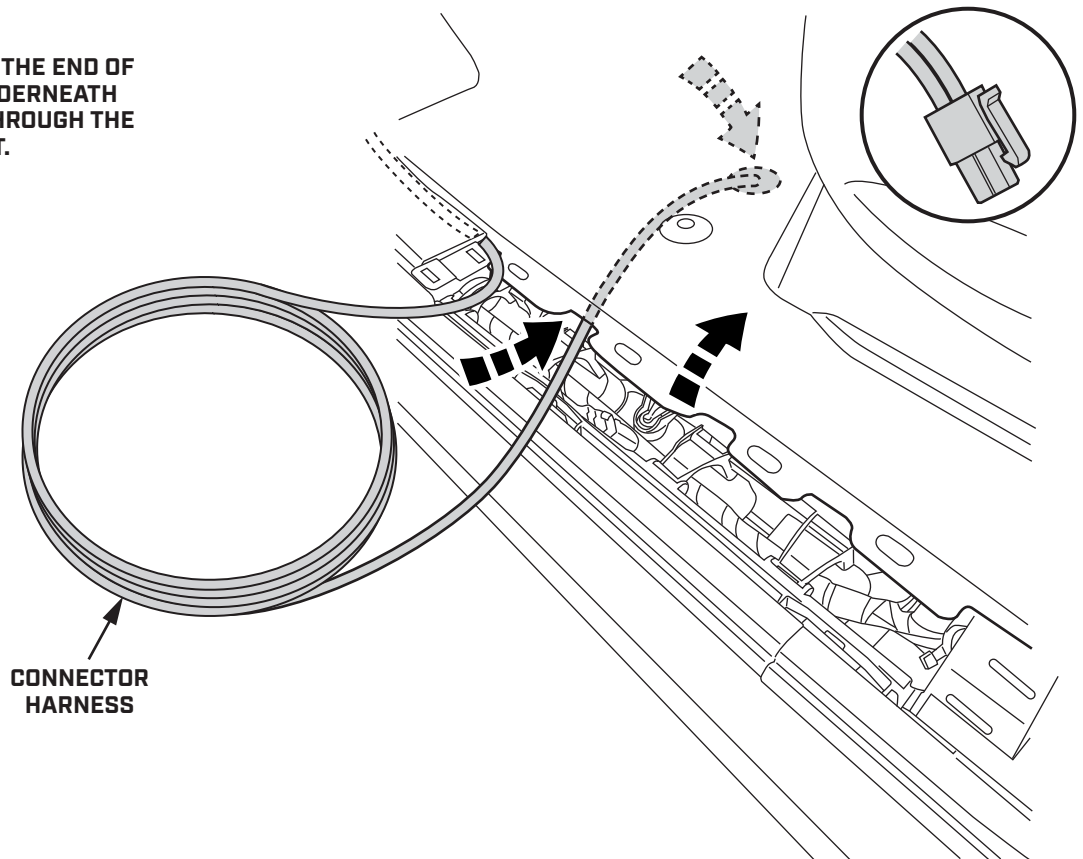

I-SHEET-NA-S2

## STEP 40

CAREFULLY PULL THE ENTIRE LENGTH OF THE CONNECTOR HARNESS DOWN THROUGH THE GROMMET.

IT IS RECOMMENDED THAT A SEALING COMPOUND BE APPLIED TO THE OPENING FOR WEATHER AND DIRT PROTECTION.

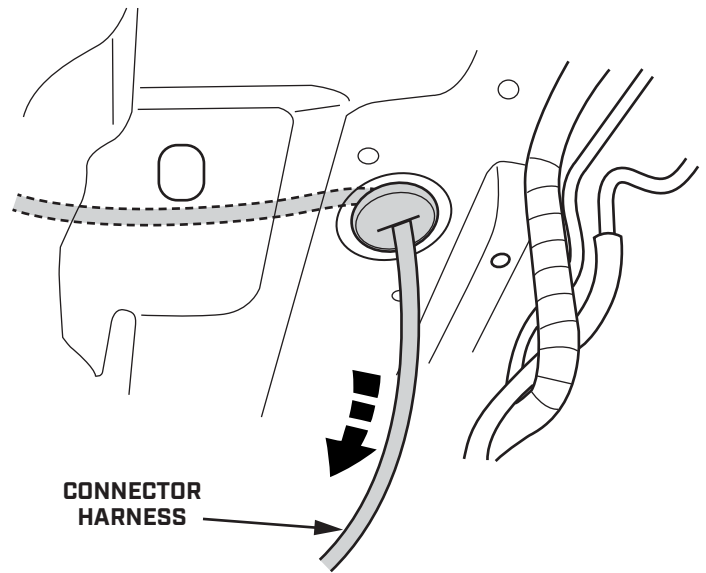

## STEP 41

FROM UNDERNEATH THE VEHICLE, BEGIN ROUTING THE CONNECTOR HARNESS OVER THE TOP OF THE DRIVER SIDE FRAME RAIL.

SECURE THE HARNESS ALONG THE OUTSIDE OF THE FRAME WITH CABLE TIES AS SHOWN.

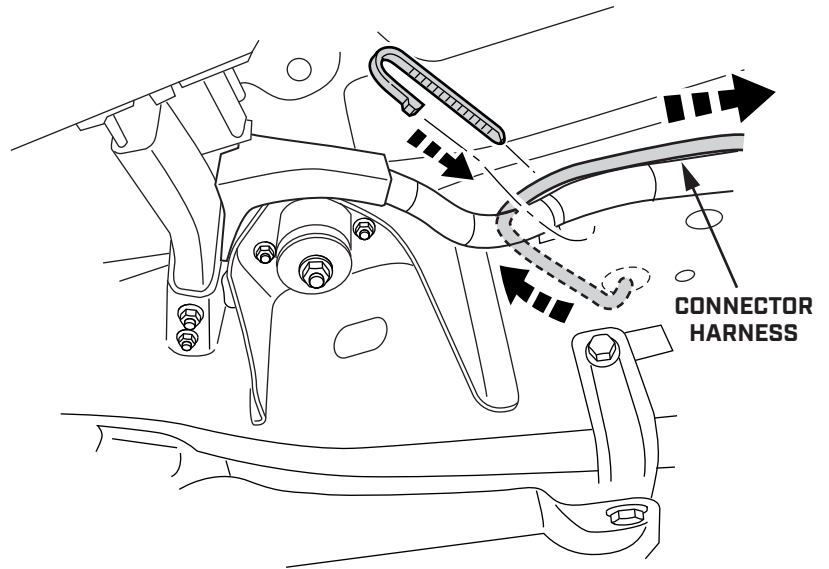
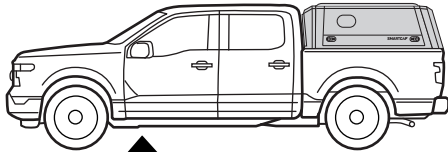

## STEP 42

CONTINUE ROUTING THE CONNECTOR HARNESS TOWARDS THE REAR OF THE VEHICLE, SECURING TO THE VEHICLE WITH CABLE TIES WHEN NECESSARY.

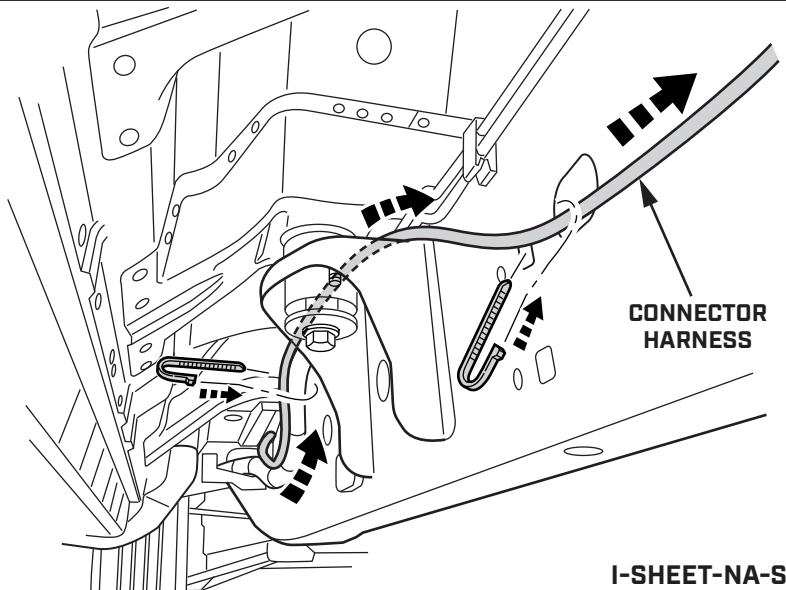
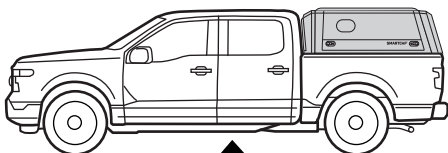

I-SHEET-NA-S2

## STEP 43

ROUTE THE CONNECTOR HARNESS UP AND OVER THE REAR WHEEL WELL.

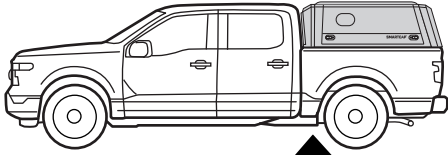

CONNECTOR HARNESS

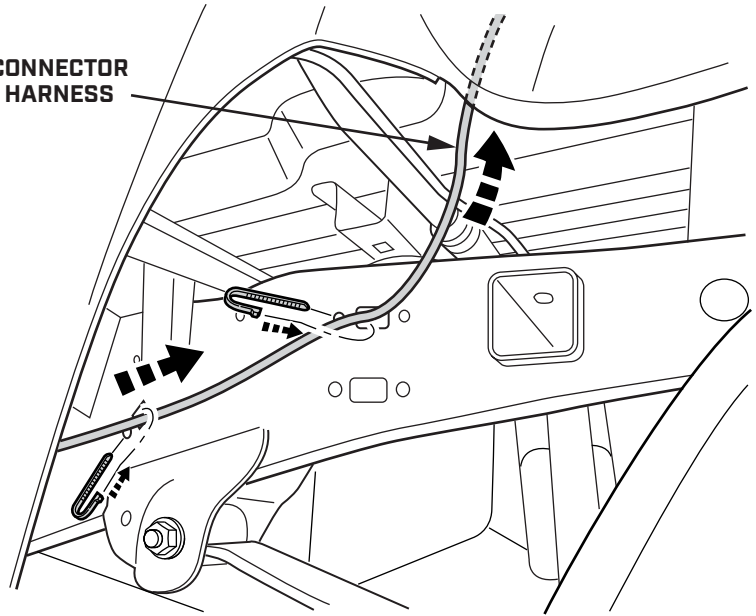

## STEP 44

ROUTE THE CONNECTOR HARNESS DOWN OVER THE BACK OF THE REAR WHEEL WELL AND SECURE WITH CABLE TIE AS SHOWN.

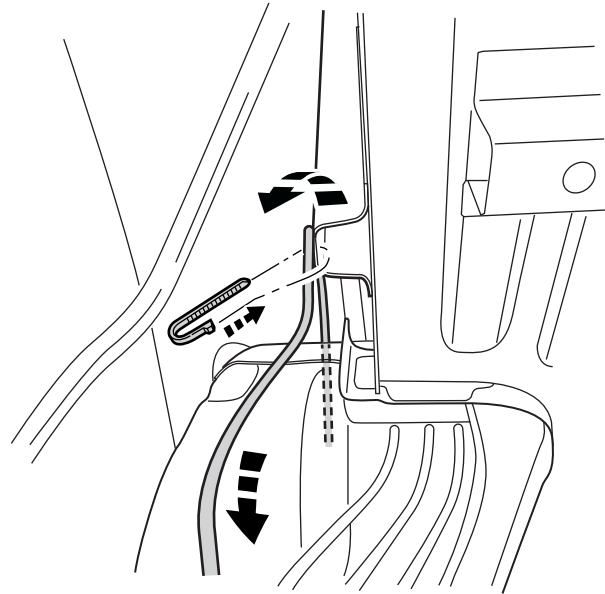
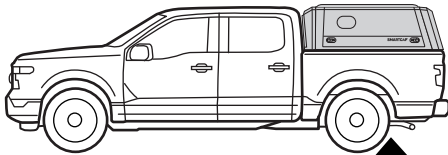

## STEP 45

REMOVE THE BOLTS HOLDING THE DRIVER SIDE TAILLIGHT ASSEMBLY

PLACE THE TAILLIGHT CAREFULLY ON THE TAILGATE. DO NOT UNPLUG ANY CONNECTORS

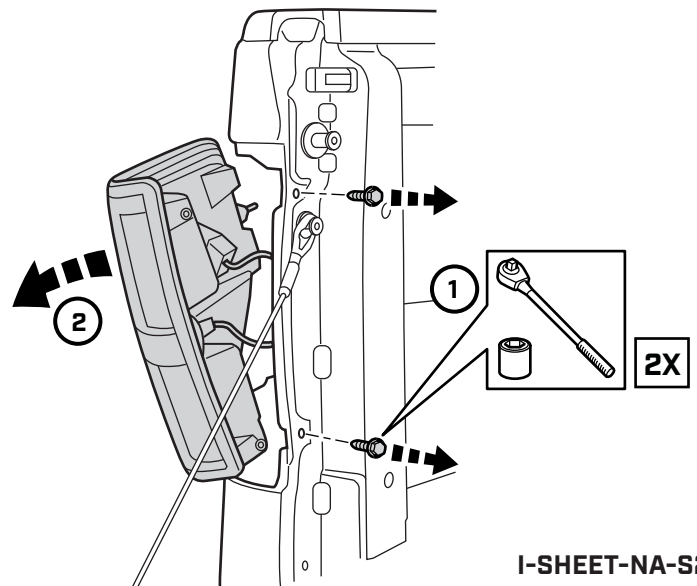

I-SHEET-NA-S2



## STEP 46

ROUTE THE CONNECTOR HARNESS UP TOWARDS THE TAILLIGHT CAVITY.

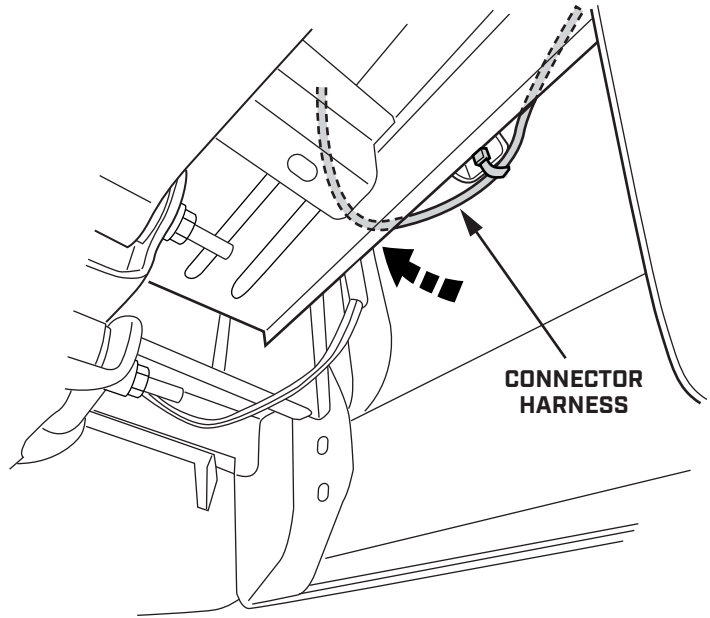
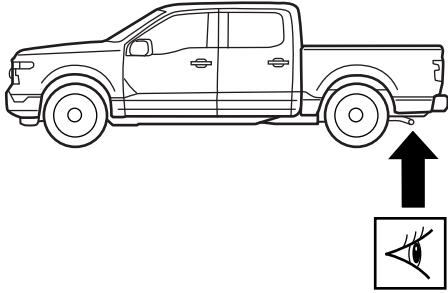

## STEP 47

CAREFULLY PULL THE CONNECTOR HARNESS OUT THROUGH THE TAILLIGHT CAVITY.

ROUTE THE CONNECTOR HARNESS UP AND OUT THROUGH THE HOLE IN THE SIDE OF THE BED.

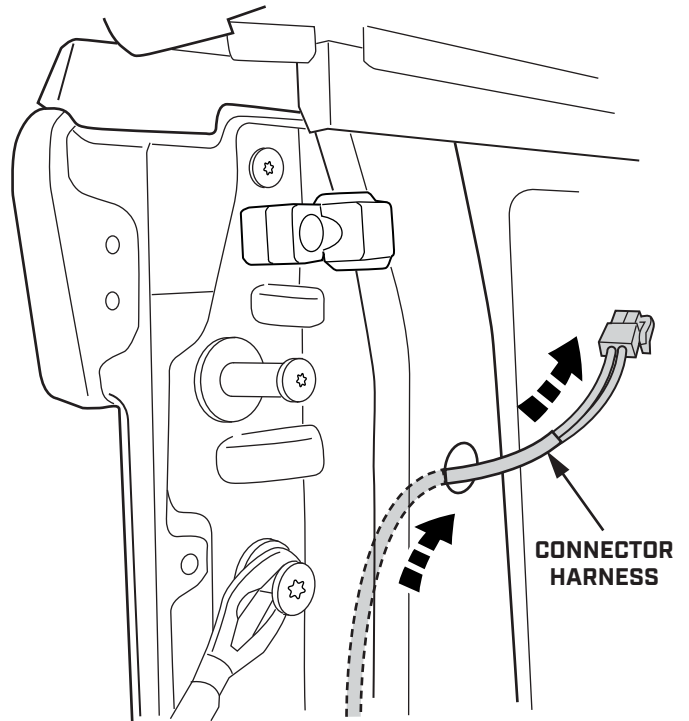
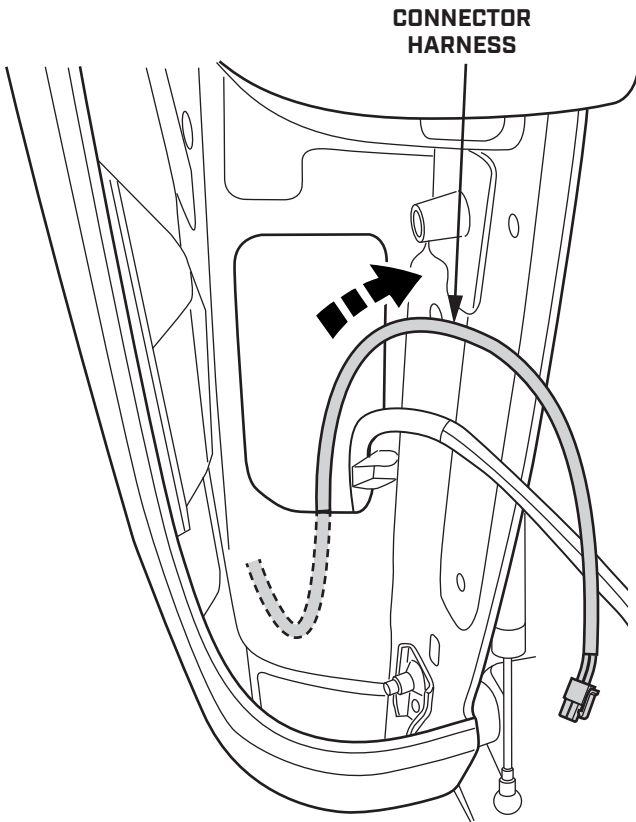

I-SHEET-NA-S2

## STEP 48

LOCATE AND DISCONNECT THE THIRD BRAKE LIGHT EXTENSION HARNESS FROM THE INSIDE BACK LEFT CORNER OF THE SMARTCAP.

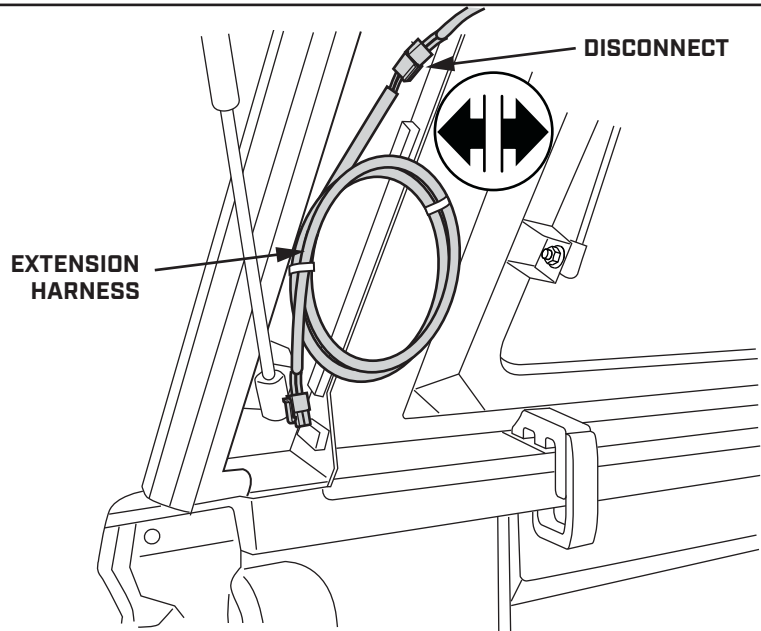

## STEP 49

CONNECT THE 2-PIN PLUG FROM THE CONNECTOR HARNESS TO THE THIRD BRAKE LIGHT HARNESS.

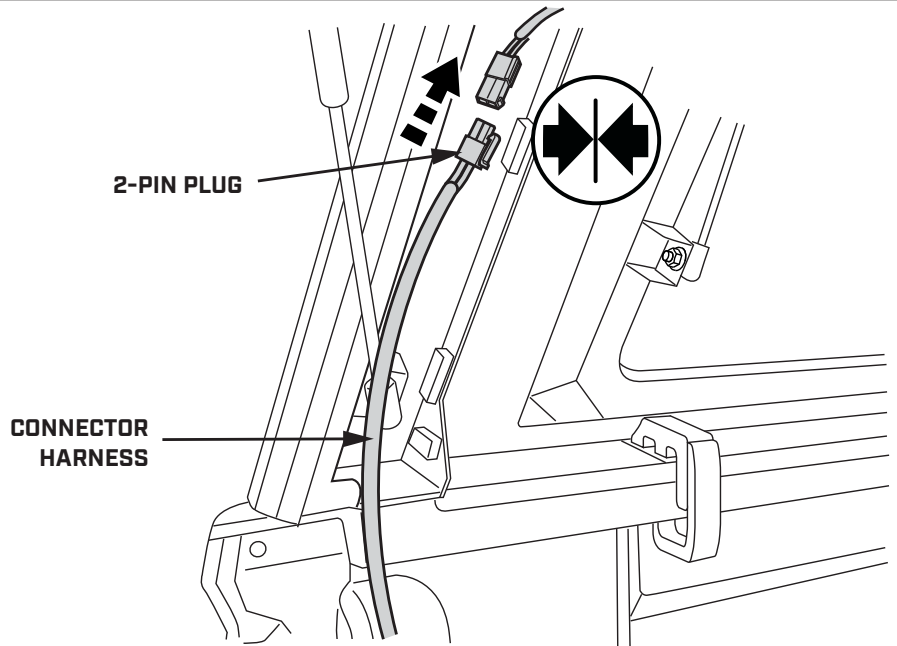

## STEP 50

APPLY AN ADHESIVE CABLE TIE BASE TO THE TRUCK BED AS SHOWN. SECURE THE CONNECTOR HARNESS WITH A CABLE TIE.

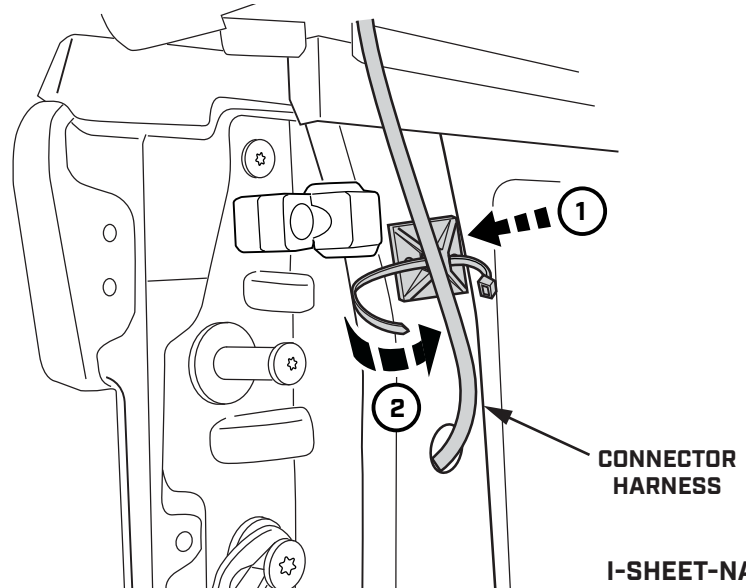
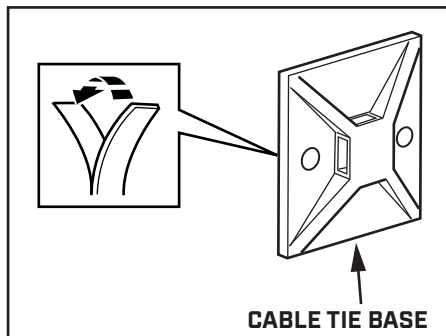

I-SHEET-NA-S2

## STEP 51

REINSTALL THE TAILLIGHT ASSEMBLY.

BUNDLE EXTRA HARNESS LENGTH IN THE TAIL LIGHT CAVITY AND SECURE WITH A CABLE TIE.

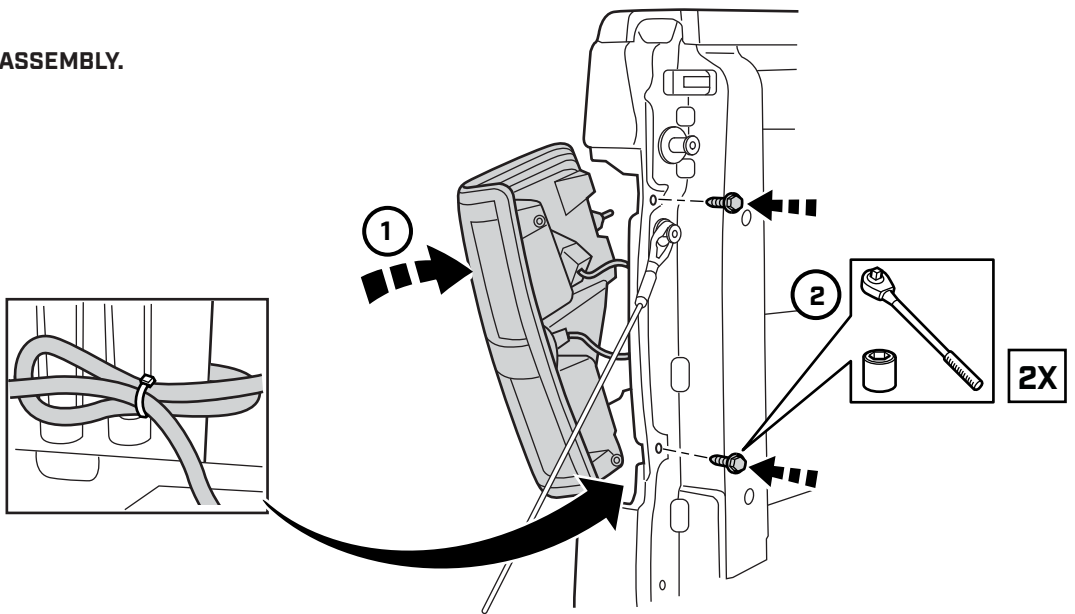

## STEP 52



### TEST YOUR BRAKE LIGHTS & TURN SIGNALS

- ▼ START THE TRUCK. SOME MODELS MAY TAKE UP TO 30 SECONDS FOR THE VEHICLE TO DETECT THE NEW CONNECTION.
- ▼ CHECK THE BRAKE LIGHTS AND TURN SIGNALS TO BE SURE THEY ARE FUNCTIONING PROPERLY.
- ▼ ONCE YOU HAVE CONFIRMED THAT THE LIGHTS ARE WORKING CORRECTLY, SECURE THE HARNESS WITH CABLE TIES.
- ▼ BE SURE NOT TO INTERFERE WITH ANY MOVING PARTS ON THE VEHICLE.

# SMARTCAP<sup>®</sup>

THANKS FOR YOUR PURCHASE.  
PLEASE LET US KNOW IF YOU HAVE ANY QUESTIONS.

[SMARTCAP.COM](http://SMARTCAP.COM)

[SUPPORT.NA@SMARTCAP.COM](mailto:SUPPORT.NA@SMARTCAP.COM) - NORTH AMERICA  
[SUPPORT.SA@SMARTCAP.COM](mailto:SUPPORT.SA@SMARTCAP.COM) - REST OF WORLD



I-SHEET-NA-S2