

SMARTCAP®

INSTRUCTION GUIDE FORD RANGER EDITION 2024-CURRENT (5th Generation)

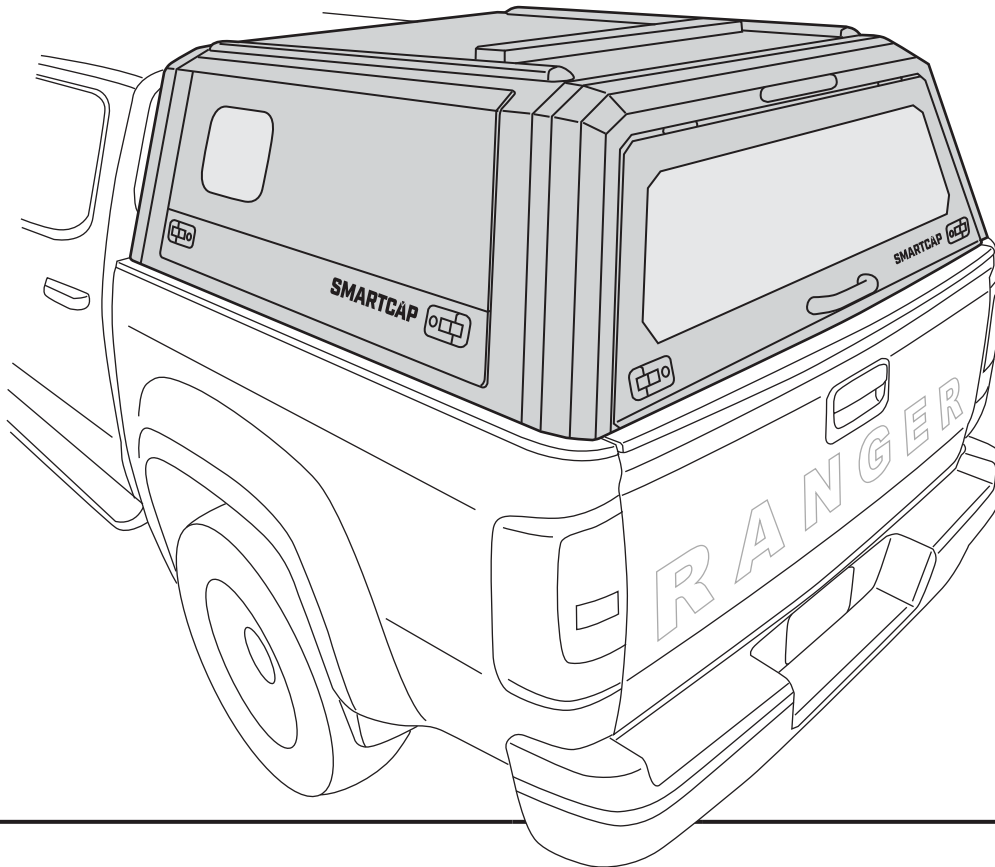

- ▼ **PREPARE A CLEAN WORK AREA.**
- ▼ **WE RECOMMEND A MINIMUM OF 2 PEOPLE FOR ASSEMBLY AND 4 PEOPLE FOR INSTALLATION.**
- ▼ **ENSURE THE REQUIRED TOOLS ARE PRESENT AND ALL HARDWARE CONTENTS ARE ACCOUNTED FOR.**
- ▼ **NEVER USE ACETONE OR THINNERS ON PAINTED PARTS.**
- ▼ **READ THROUGH THE ENTIRE INSTRUCTION GUIDE BEFORE STARTING THIS PROCEDURE AND FOLLOW THE STEPS CAREFULLY TO AVOID ANY DAMAGE TO THE COMPONENTS OR THE VEHICLE.**

SMARTCAP.COM

SUPPORT.NA@SMARTCAP.COM - NORTH AMERICA

SUPPORT.SA@SMARTCAP.COM - REST OF WORLD



I-SHEET-NA-R2

DISCLAIMER

IT IS A REQUIREMENT FROM FORD THAT ANY 2024 NEXT GEN RANGER WITH ACCESSORIES EXTENDING ABOVE THE BEDRAILS, AND WEIGHING IN EXCESS OF 99LBS, BE FITTED WITH THEIR LOAD BOX REINFORCEMENT BRACKETS (AKA J-BRACES) PRIOR TO INSTALLATION, TO AVOID NEGATIVELY IMPACTING YOUR VEHICLE'S FACTORY WARRANTY. PLEASE CONSULT YOUR OWNER'S MANUAL OR SELLING DEALER FOR MOR INFORMATION.

TOOLS REQUIRED

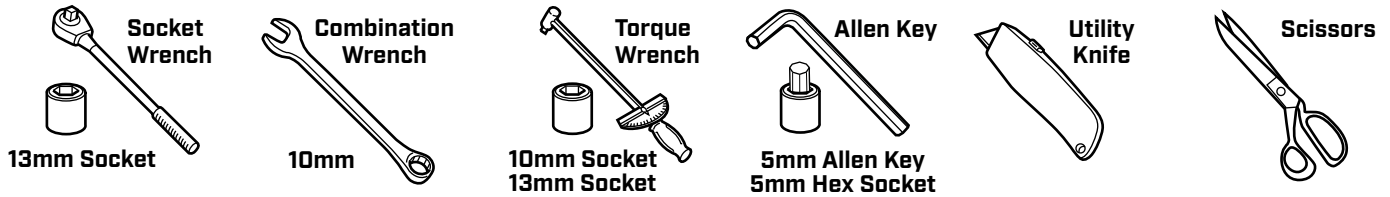

IMPORTANT

- ▼ USE ONLY THE TOOLS RECOMMENDED ABOVE.
- ▼ USE ONLY THE HARDWARE PROVIDED IN THIS KIT.
- ▼ ASSISTANCE WILL BE NEEDED FOR THIS INSTALLATION. FOUR PEOPLE ARE RECOMMENDED TO LIFT THE SMARTCAP ONTO THE VEHICLE.
- ▼ AVOID PINCHING OR CRUSHING HANDS AND FINGERS.
- ▼ INSPECT ALL KIT COMPONENTS FOR DAMAGE BEFORE ASSEMBLY.
- ▼ NEVER USE ACETONE OR THINNERS ON PAINTED PARTS.

COMPONENTS

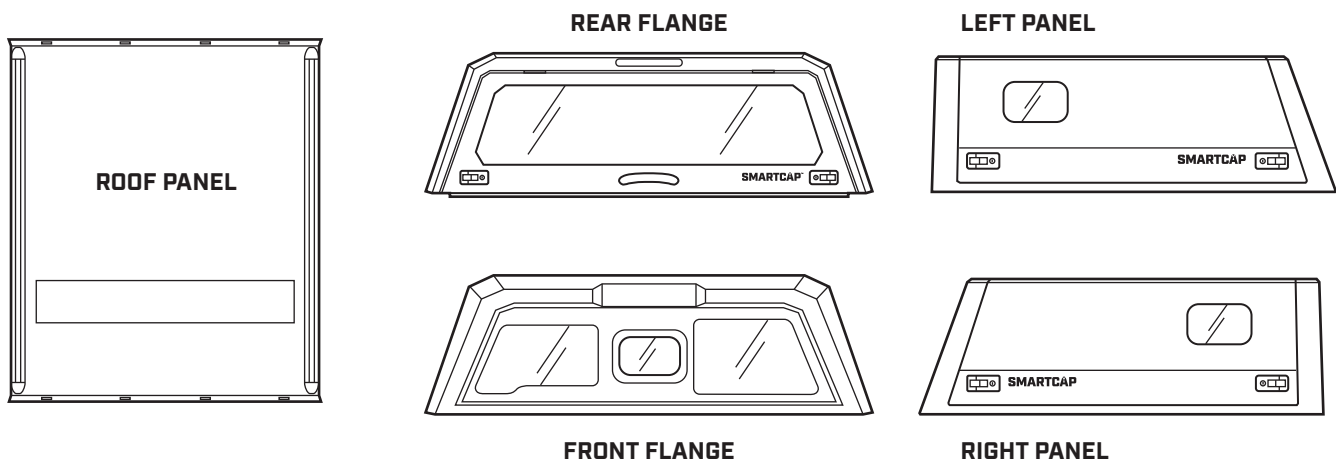

I-SHEET-NA-R2

ASSEMBLY HARDWARE

FITMENT KIT

M6 x 10mm BOLT

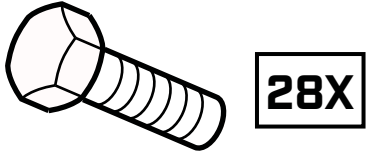

**FASTENER
BLOCK CLAMP**

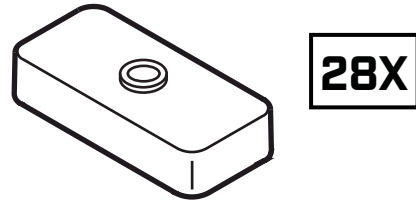

**M6 LOCK
WASHER**



**FASTENER
BLOCK**

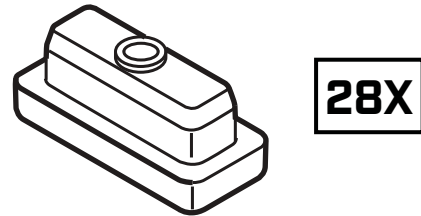

D - RUBBER



SPARE PARTS

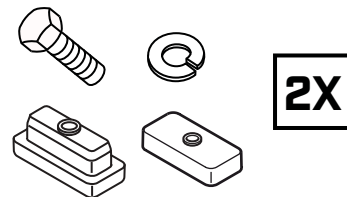

PRE-FASTENED TO ROOF PANEL

**M6 FENDER
WASHER**



**M6 LOCK
NUT**



STEP 1



IMPORTANT

- ▼ BE SURE TO REMOVE ALL FIVE PANELS FROM THEIR PACKAGING AND INSPECT THE PAINTED SURFACES PRIOR TO ASSEMBLY, AS SMARTCAP WILL NOT ACCEPT WARRANTY CLAIMS AFTER ASSEMBLY IS COMPLETED. IF MANUFACTURING IMPERFECTIONS OR SHIPPING DAMAGES ARE FOUND, DO NOT CONTINUE WITH THE ASSEMBLY PROCESS AND CONTACT SUPPORT.NA@SMARTCAP.COM.

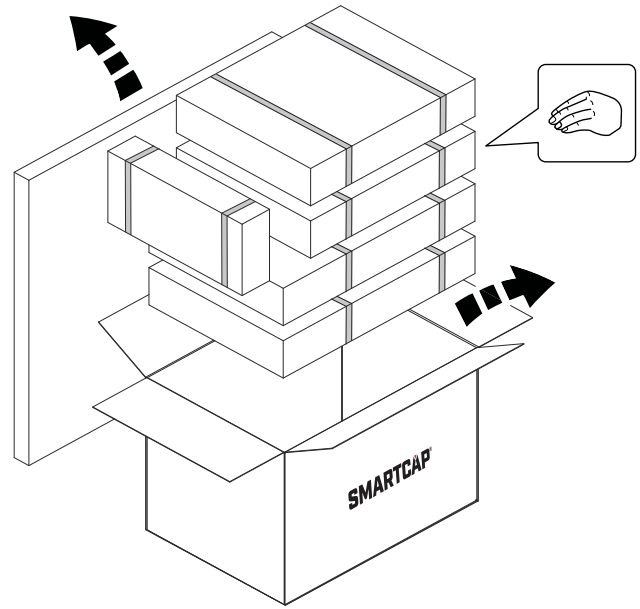

STEP 2

PLACE THE ROOF PANEL WHERE YOU PLAN TO ASSEMBLE THE CAP. REMOVE THE LID FROM THE PACKAGING AND PLACE IT NEXT TO THE ROOF PANEL.

STICKER SIDE UP

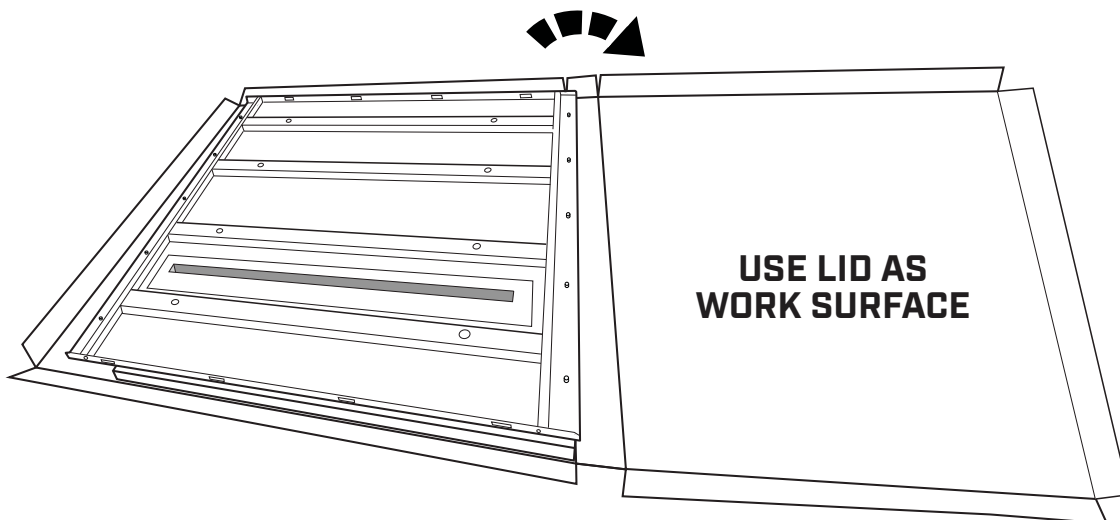
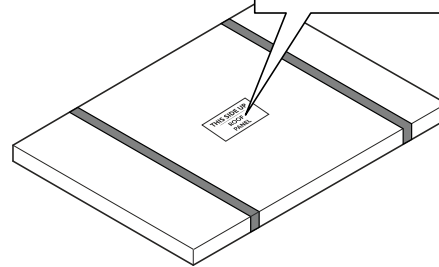

I-SHEET-NA-R2

STEP 3

USE A 10MM COMBINATION WRENCH TO REMOVE ALL HARDWARE FROM THE ROOF PANEL AND SAVE FOR REUSE.



AIR VENT INDICATES REAR

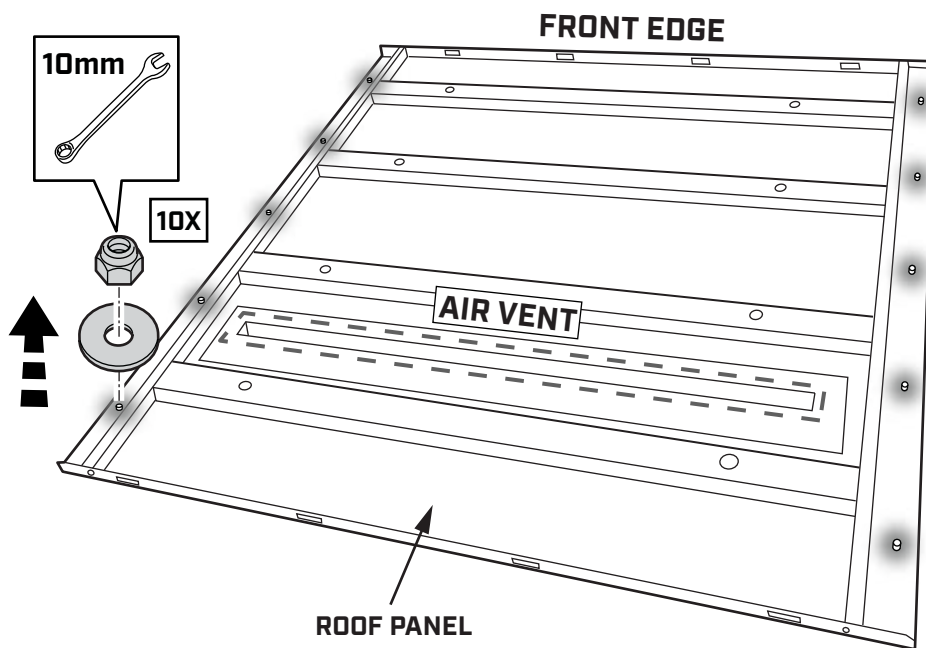

STEP 4

LOCATE THE RIGHT PANEL IN THE SMARTCAP PACKAGE AND BRING IT TO YOUR WORK AREA.



SLANTED EDGE INDICATES REAR

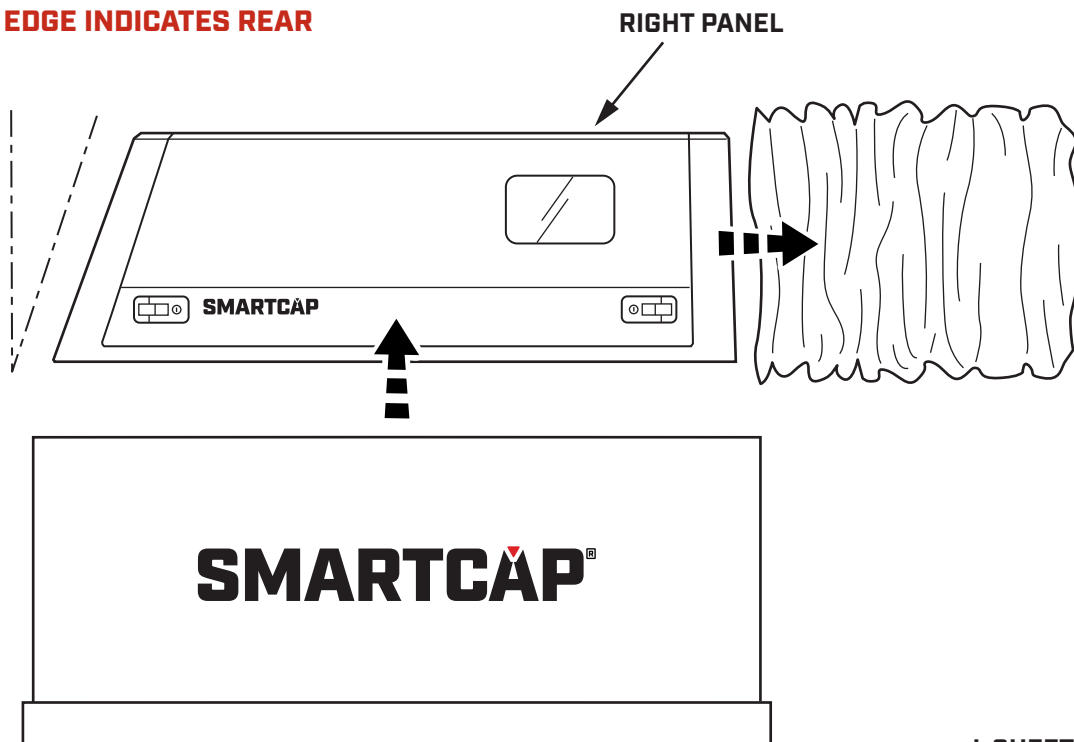

I-SHEET-NA-R2

STEP 5

INSERT PANEL TABS INTO NARROW SLOTS JUST ABOVE FOAM PADDING ON ROOF PANEL.

TAP FIRMLY WITH PALM OF HAND UNTIL THERE IS A 2-3MM GAP.

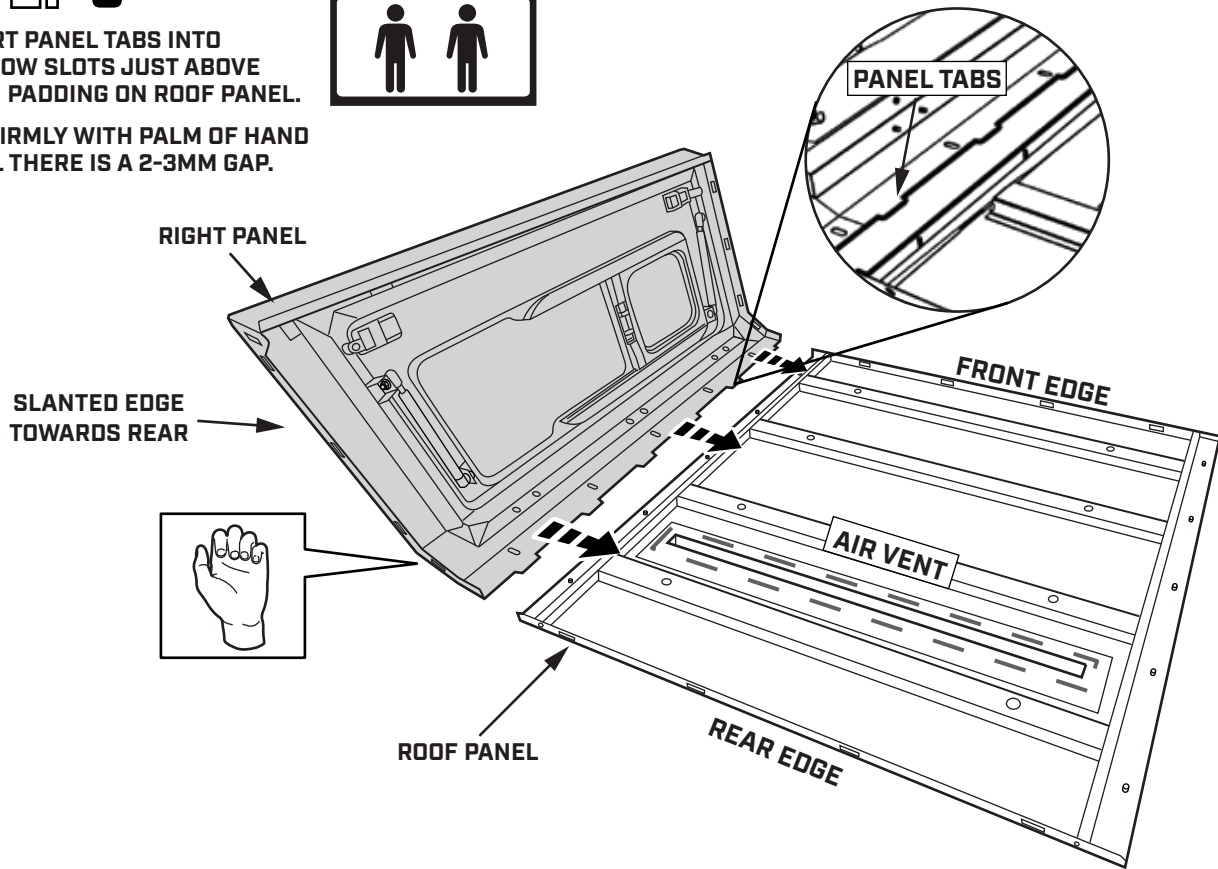

STEP 6

HAND TIGHTEN M6 LOCK NUT WITH M6 FENDER WASHER TO ALL BOLTS.

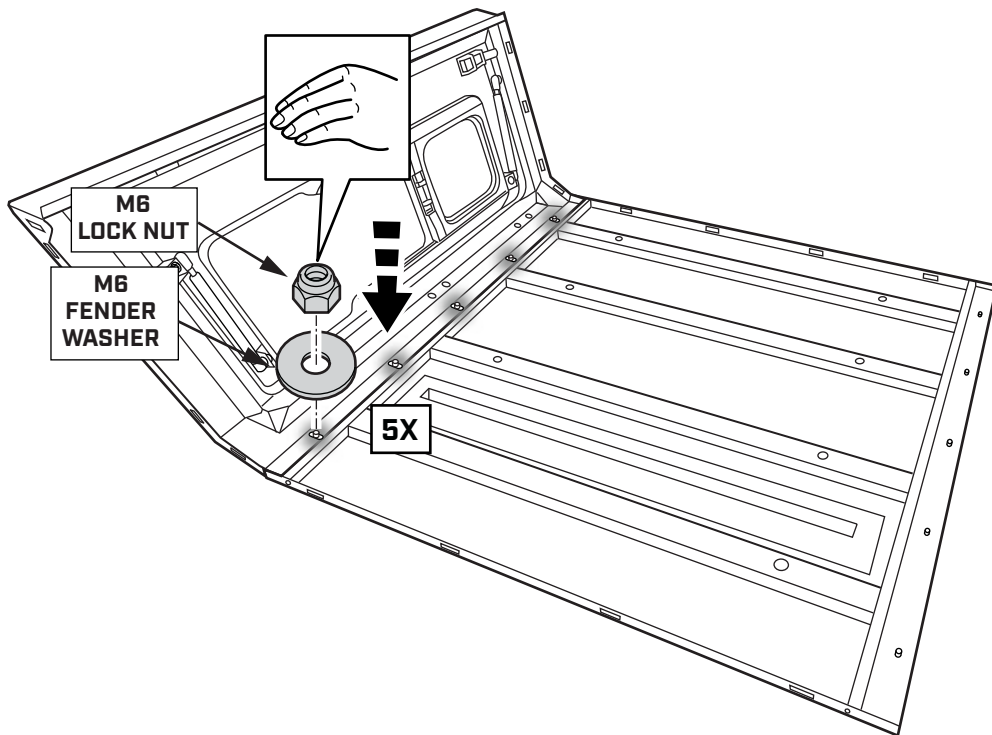

STEP 7

LOCATE THE LEFT PANEL IN THE SMARTCAP PACKAGE AND BRING IT TO YOUR WORK AREA.



SLANTED EDGE INDICATES REAR

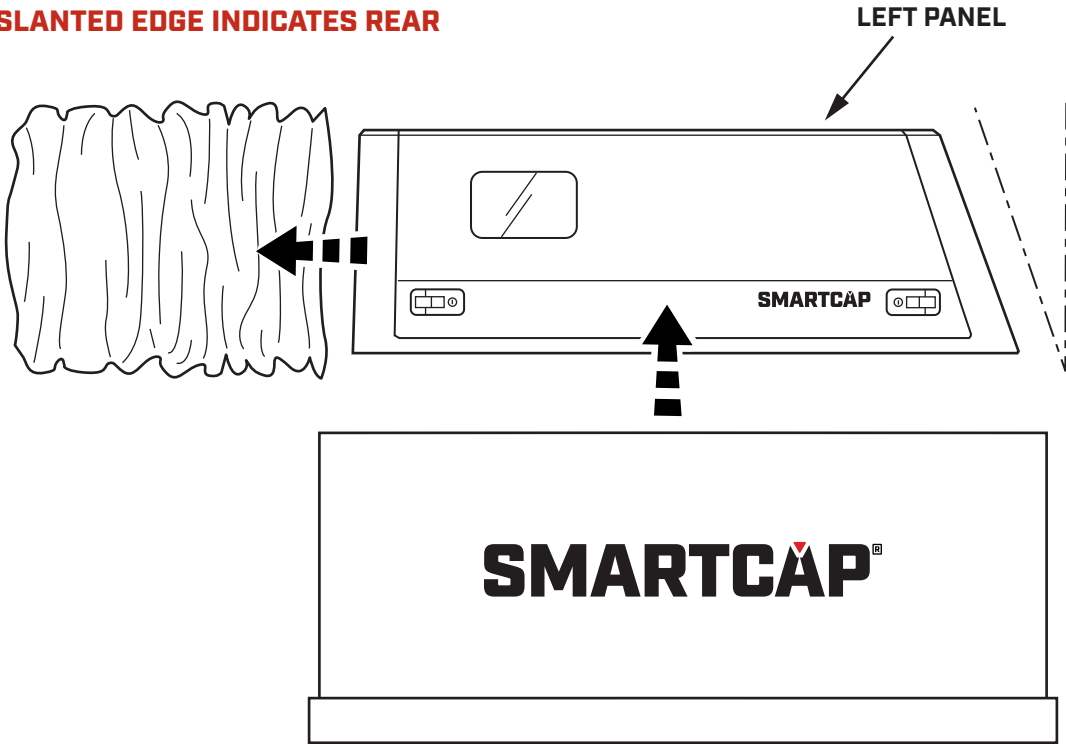

STEP 8

INSERT PANEL TABS INTO NARROW SLOTS JUST ABOVE FOAM PADDING ON ROOF PANEL.



TAP FIRMLY WITH PALM OF HAND UNTIL THERE IS A 2-3MM GAP.

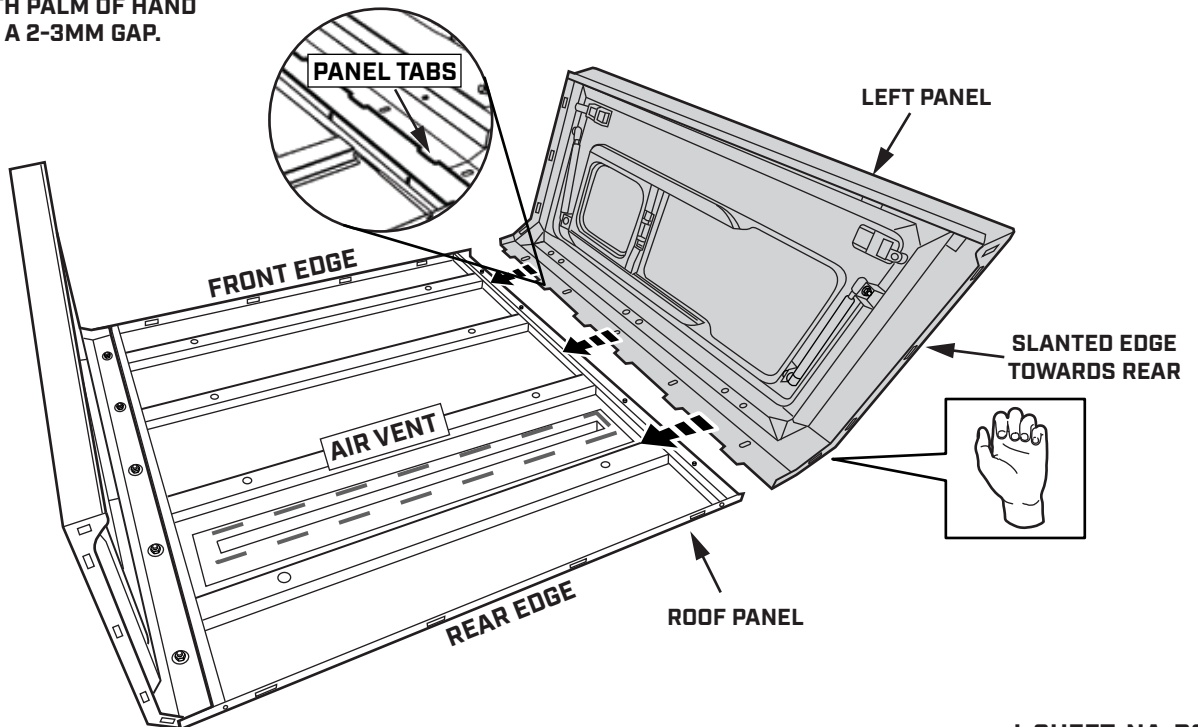

I-SHEET-NA-R2

STEP 9

HAND TIGHTEN M6 LOCK NUT WITH M6 FENDER WASHER TO ALL BOLTS.

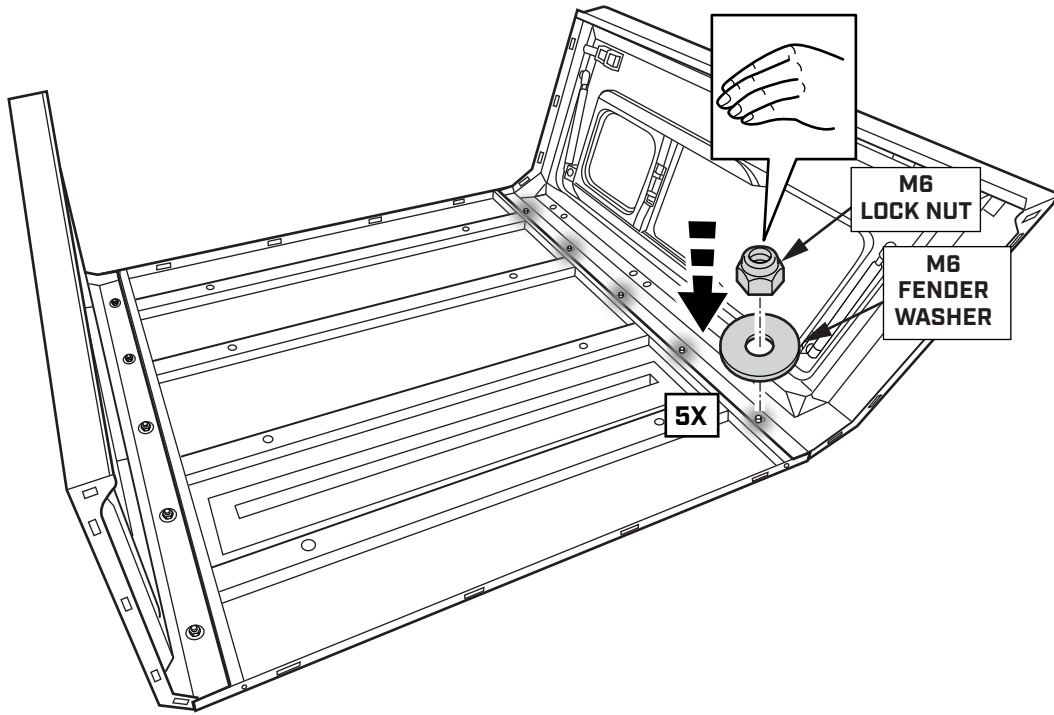

STEP 10

PUSH THE SMARTCAP TO EXPOSE A FEW INCHES OF STYROFOAM UNDERNEATH THE ROOF PANEL TO PROVIDE SUPPORT FOR THE FRONT FLANGE.

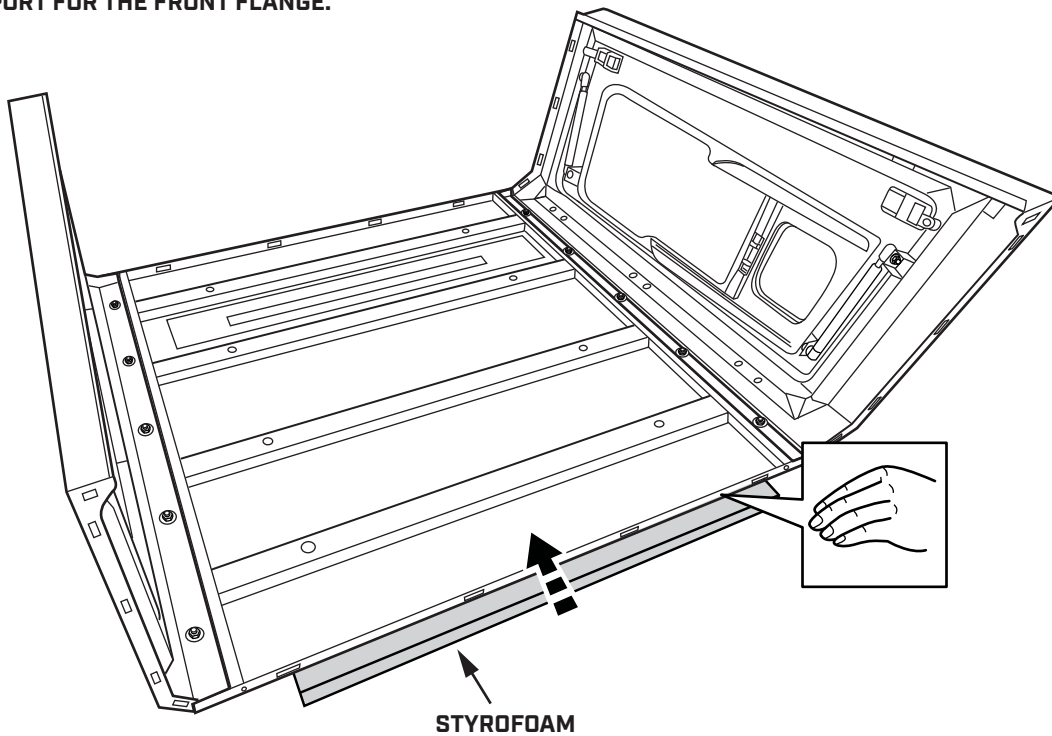

STEP 11

RETRIEVE THE NECESSARY HARDWARE FROM THE FITMENT KIT.

LOCATE THE FRONT FLANGE IN THE SMARTCAP PACKAGE AND BRING IT TO YOUR WORK AREA.

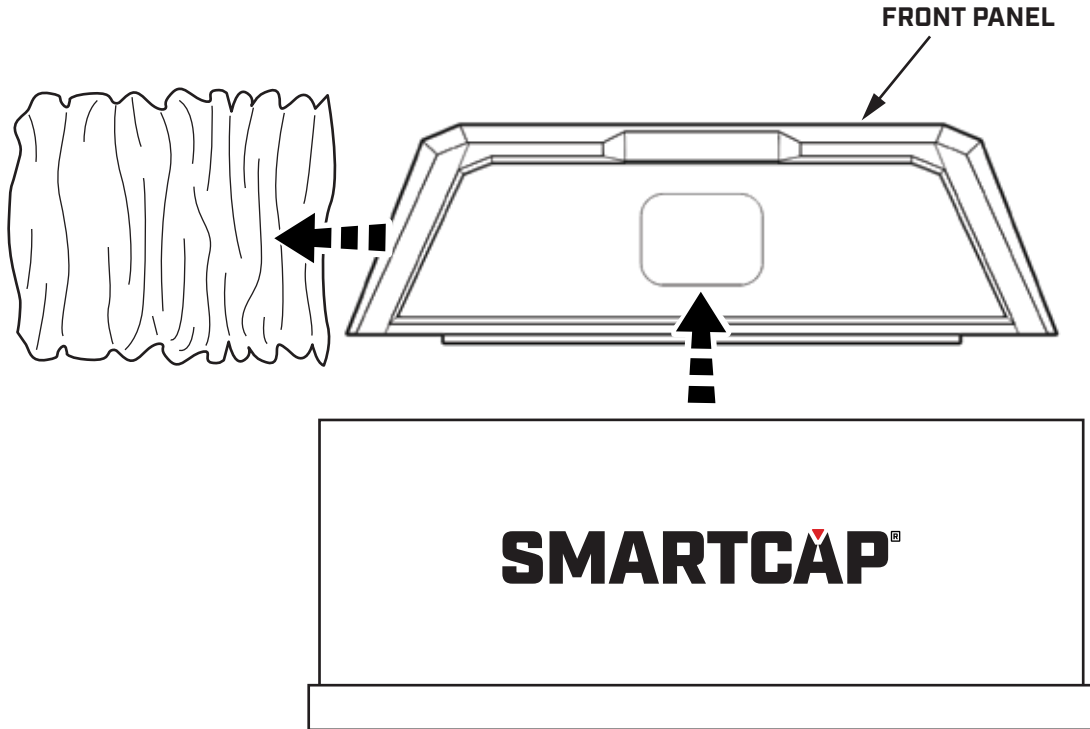

STEP 12

PLACE FRONT FLANGE AS SHOWN BELOW.

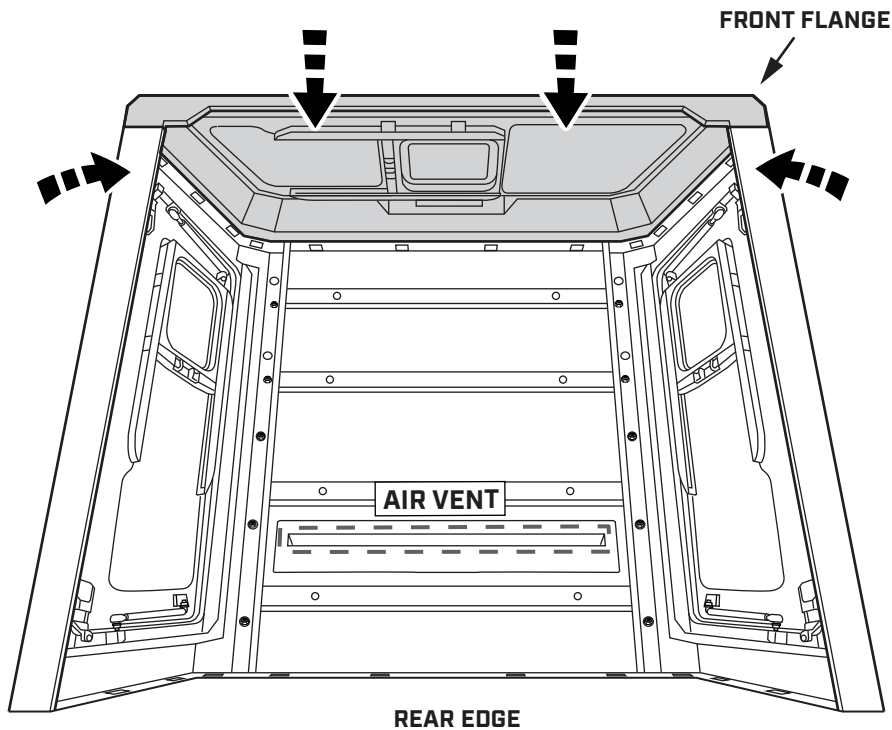

STEP 13

INSTALL HARDWARE ALONG FRONT FLANGE WITH M6 BOLT ON INSIDE.

START WITH ASSEMBLING FASTENER BLOCKS 1-5.

ADJUST LEFT AND RIGHT PANELS TO ALIGN FASTENER BLOCKS 6-15 FOR ASSEMBLY.

HAND TIGHTEN IN THE SEQUENCE SHOWN.

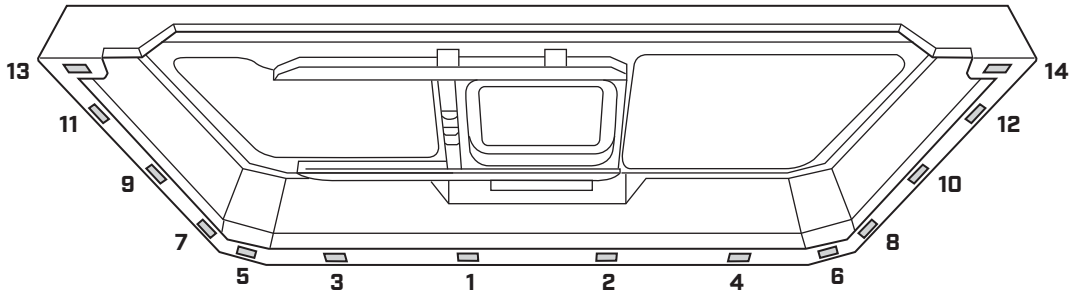
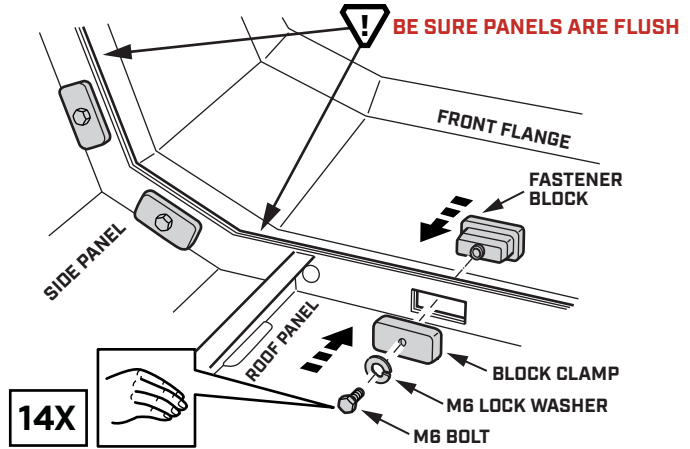

STEP 14

PUSH THE SMARTCAP TO EXPOSE A FEW INCHES OF STYROFOAM UNDERNEATH THE ROOF PANEL TO PROVIDE SUPPORT FOR THE REAR FLANGE.

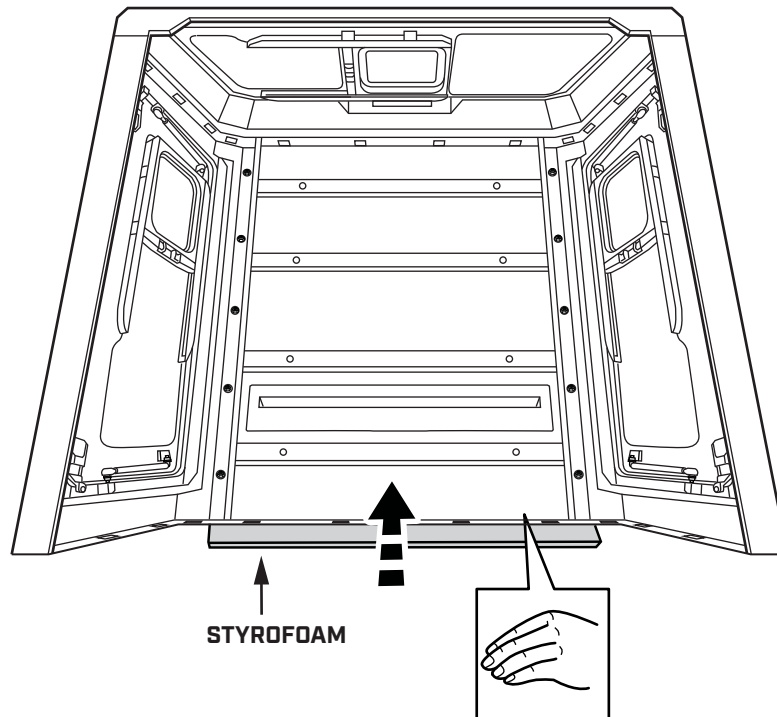

STEP 15

RETRIEVE THE NECESSARY HARDWARE FROM THE FITMENT KIT.

LOCATE THE REAR FLANGE IN THE SMARTCAP PACKAGE AND BRING IT TO YOUR WORK AREA.

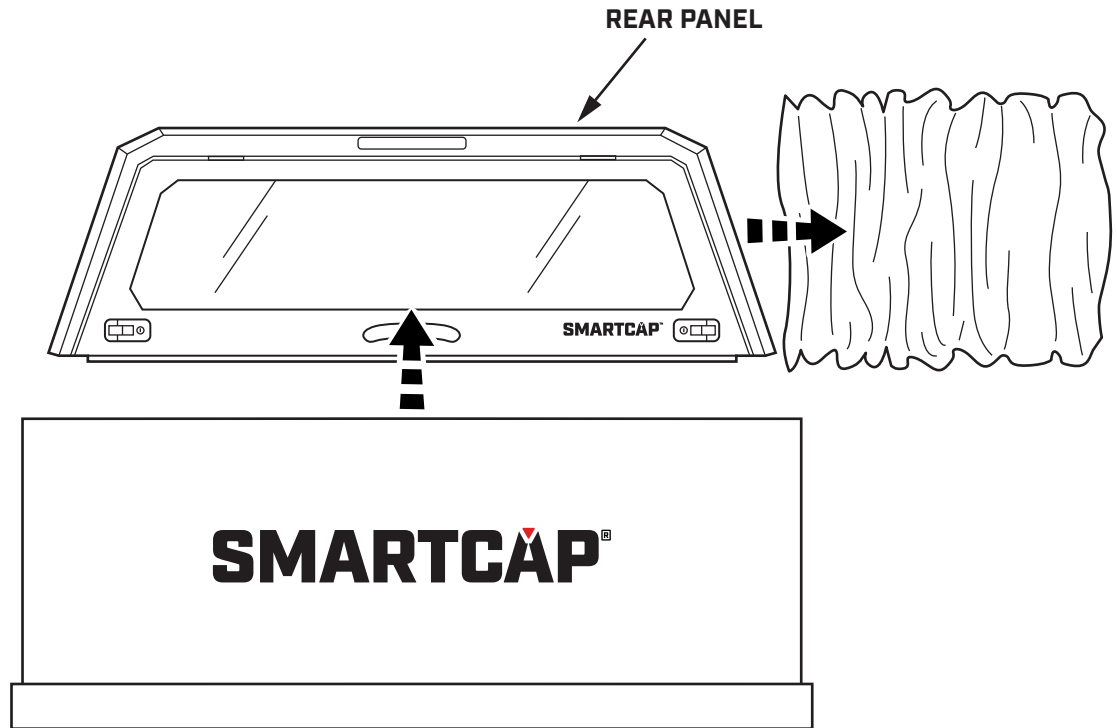
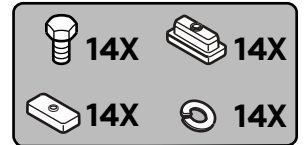

STEP 16

PLACE REAR FLANGE AS SHOWN BELOW.

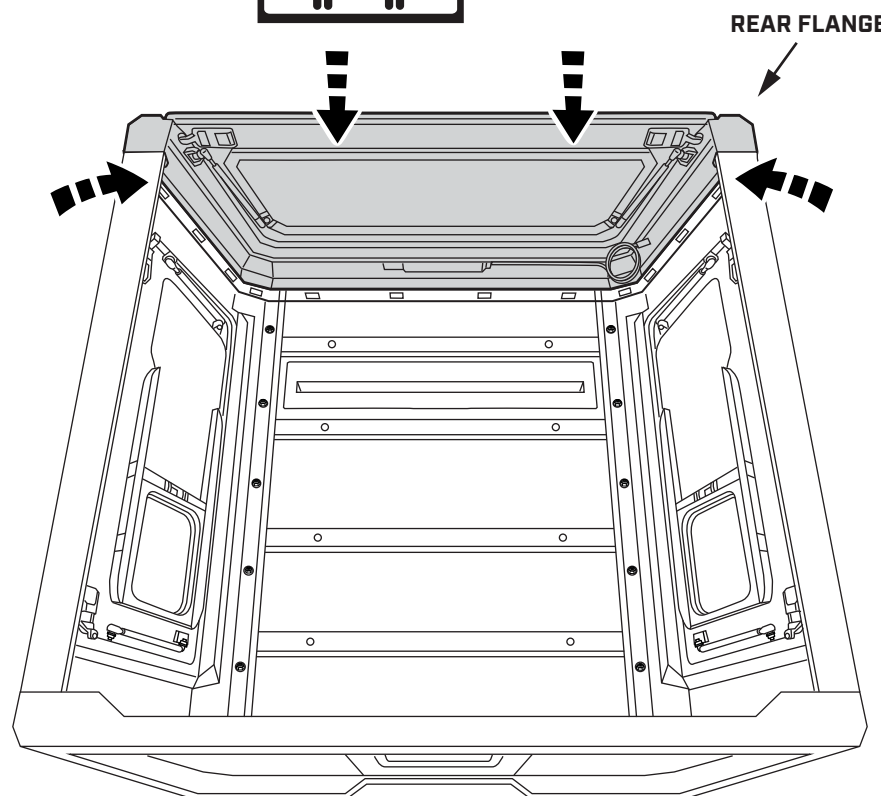

I-SHEET-NA-R2

STEP 17

INSTALL HARDWARE ALONG REAR FLANGE WITH BOLT ON INSIDE.

START WITH ASSEMBLING FASTENER BLOCKS 1-5.

ADJUST LEFT AND RIGHT PANELS TO ALIGN FASTENER BLOCKS 6-15 FOR ASSEMBLY.

HAND TIGHTEN IN THE SEQUENCE SHOWN.

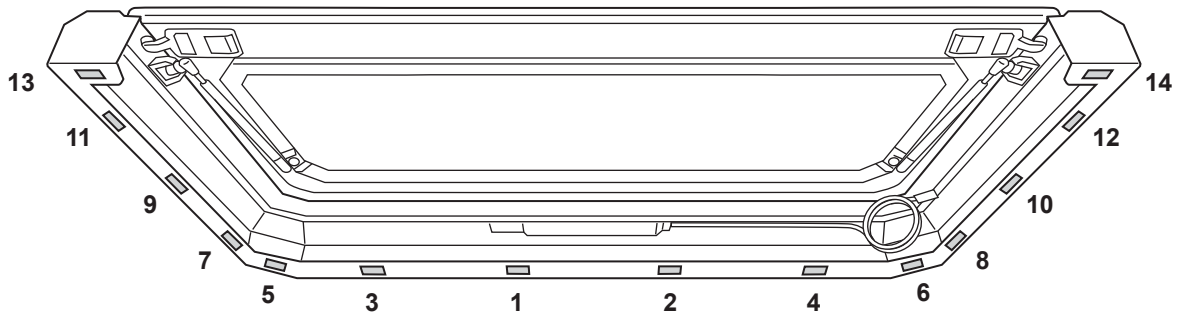
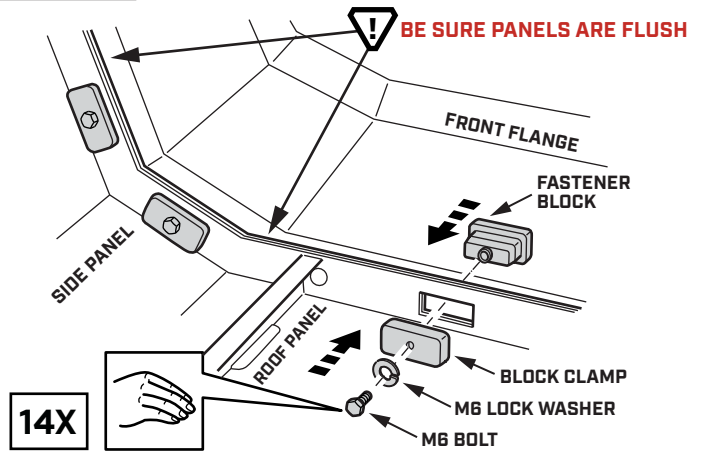

STEP 18

TIGHTEN ALL HARDWARE WITH TORQUE WRENCH AND 10MM SOCKET TO 3.7 FT. LBS. [5 NEWTON METERS]



[3.7 ft. lbs]/[5 Nm]

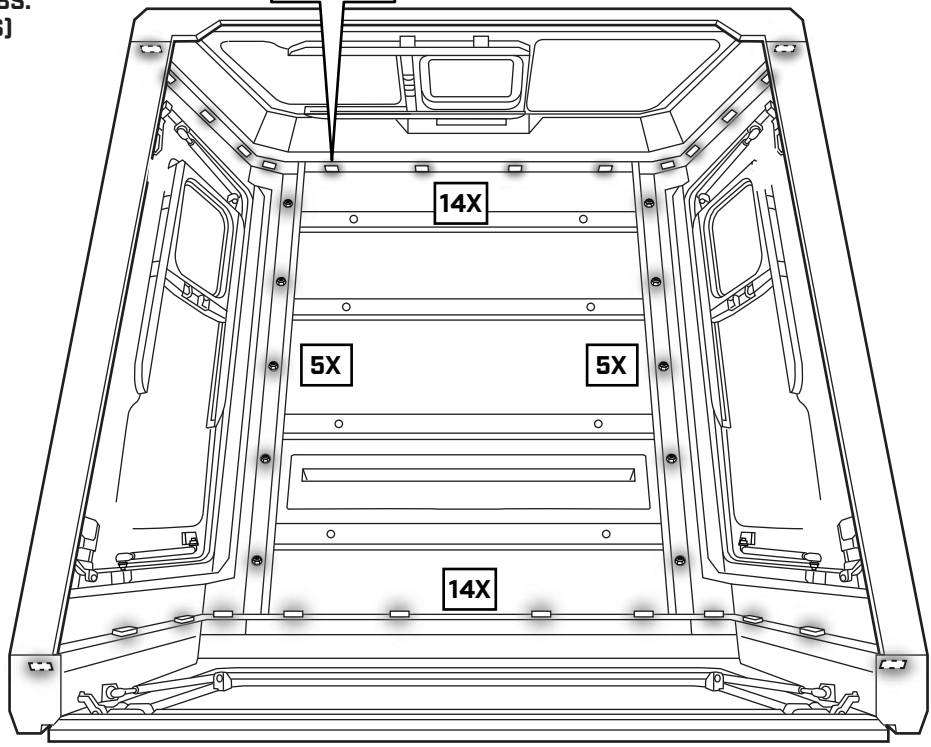

STEP 19

A LOCATE THE D-RUBBER RETENTION TAB NEXT TO THE REAR DOOR GASKET. BEND THE TAB UPWARDS AT A 45 DEGREE ANGLE.

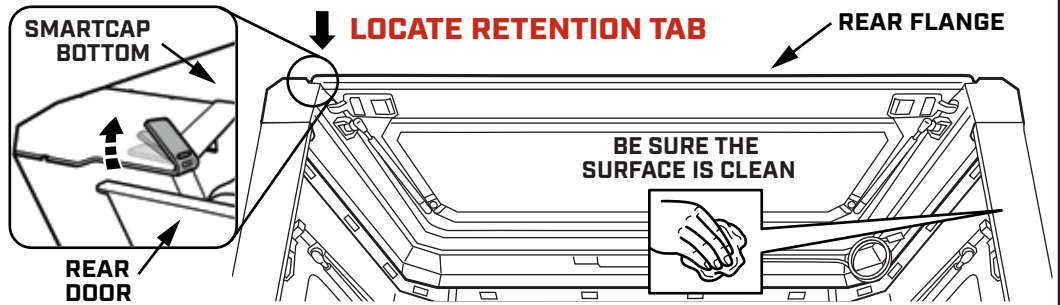

B PEEL AWAY A SMALL PORTION OF THE ADHESIVE BACKING FROM THE D-RUBBER.

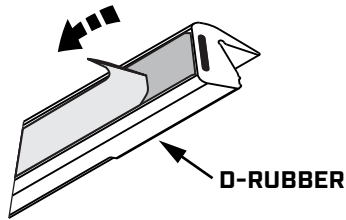

C INSERT THE TAB INTO THE D-RUBBER UNTIL THE D-RUBBER LIGHTLY BUTTS UP AGAINST REAR DOOR GASKET.

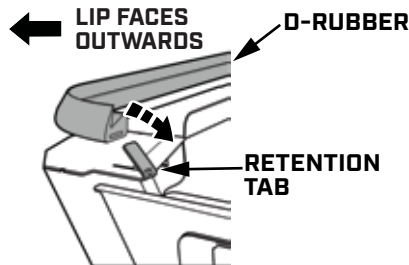

D FIRMLY PUSH THE TAB BACK DOWN TO SECURE THE D-RUBBER IN PLACE.

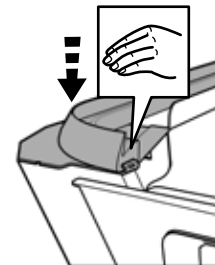

CORRECT D-RUBBER ORIENTATION

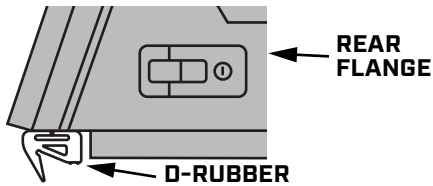

INCORRECT D-RUBBER ORIENTATION

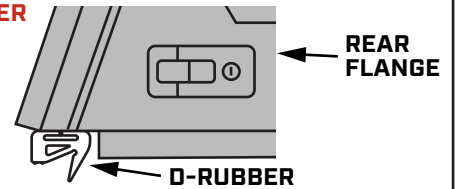

STEP 20

PEEL AWAY ADHESIVE BACKING IN SHORT LENGTHS AS YOU WORK AROUND THE EDGES.

STAY WITHIN 1/8 INCH FROM THE SMARTCAP'S OUTER EDGES.

REMOVE EXCESS WITH A STRAIGHT CUT.

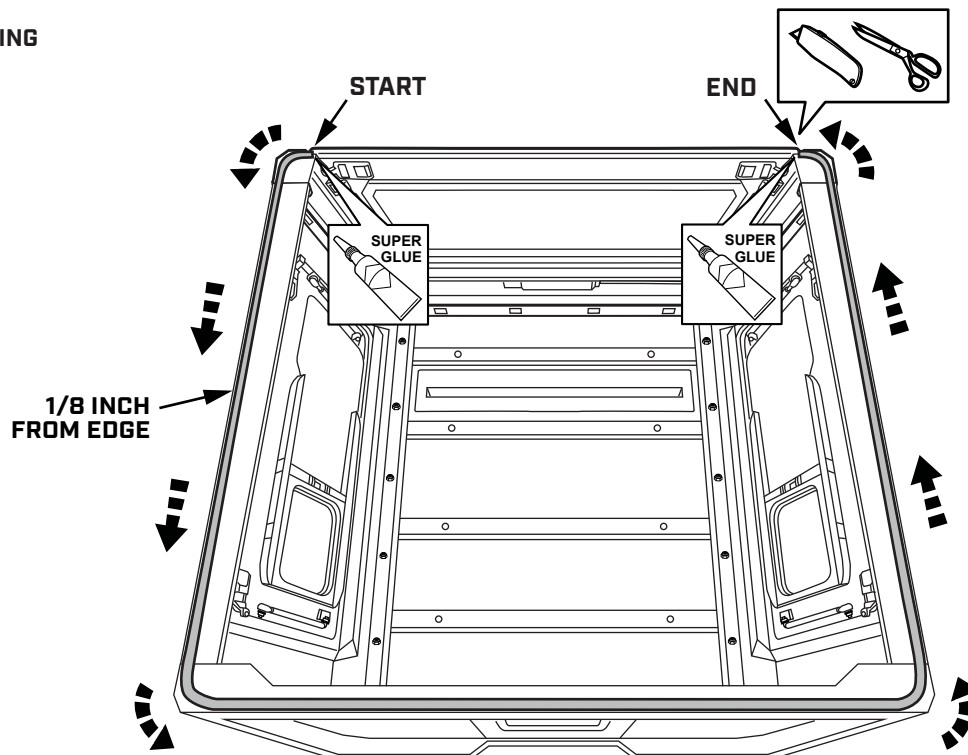

INSTALLATION HARDWARE

MOUNTING BRACKETS

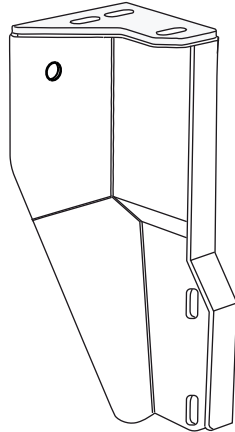
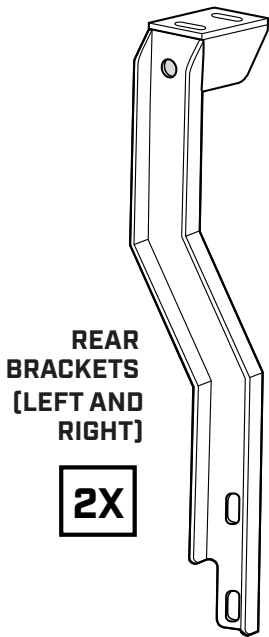

25mm x 25mm
FOAM SEAL TAPE

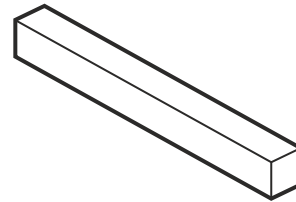

M8 x 20mm BOLT



M8 LOCK WASHER



ALUMINUM SPACER BLOCK

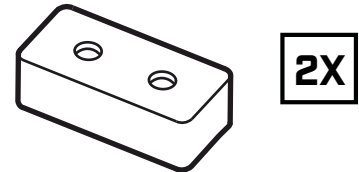

M8 x 20mm
BUTTON BOLT



M8 LOCK NUT



M8 FENDER WASHER



VEHICLE INSTALLATION



IMPORTANT

- ▼ ASSISTANCE WILL BE NEEDED FOR THIS INSTALLATION. FOUR PEOPLE ARE RECOMMENDED TO LIFT THE SMARTCAP ONTO THE VEHICLE.
- ▼ AVOID PINCHING OR CRUSHING HANDS AND FINGERS.
- ▼ READ THROUGH THE ENTIRE PROCEDURE BEFORE STARTING.

STEP 21

REMOVE THE CENTER TWO BED-RAIL CAP INSERTS AND PLACE THEM IN THE GLOVE BOX.

REPEAT ON THE OPPOSITE SIDE OF THE VEHICLE.

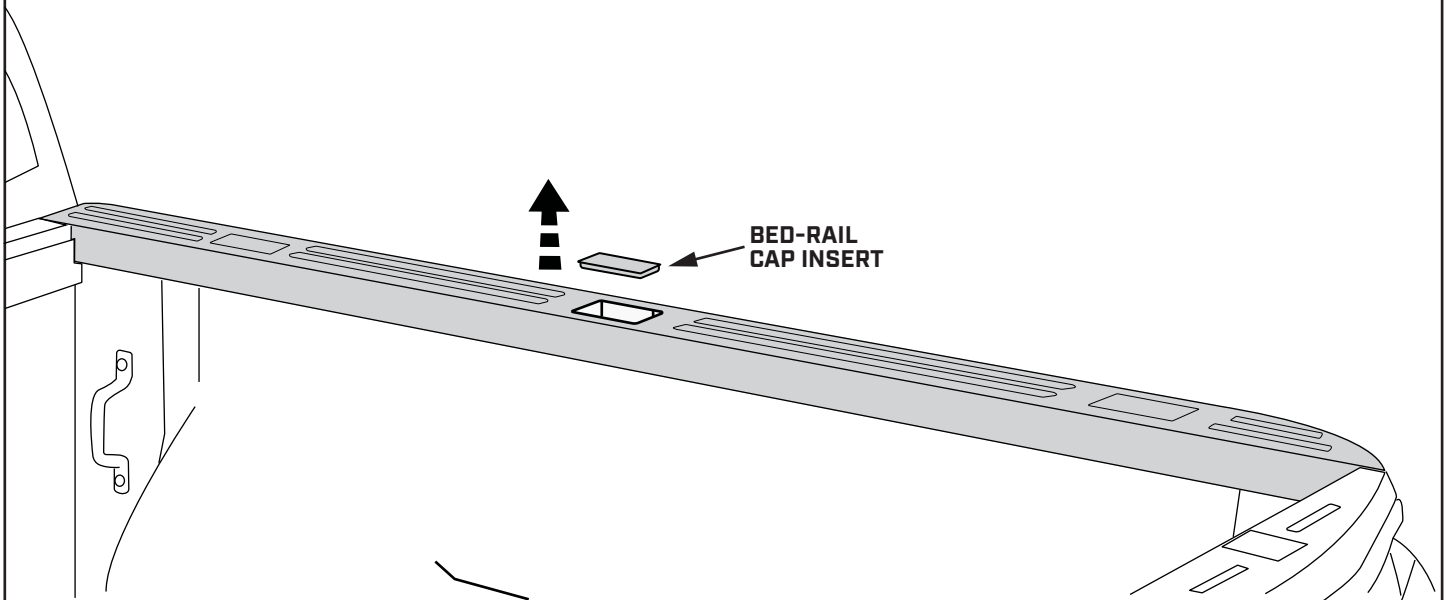

STEP 22

PLACE THE ALUMINUM SPACER BLOCK ONTO THE METAL BED-RAIL AS SHOWN.

REPEAT ON THE OPPOSITE SIDE OF THE VEHICLE.

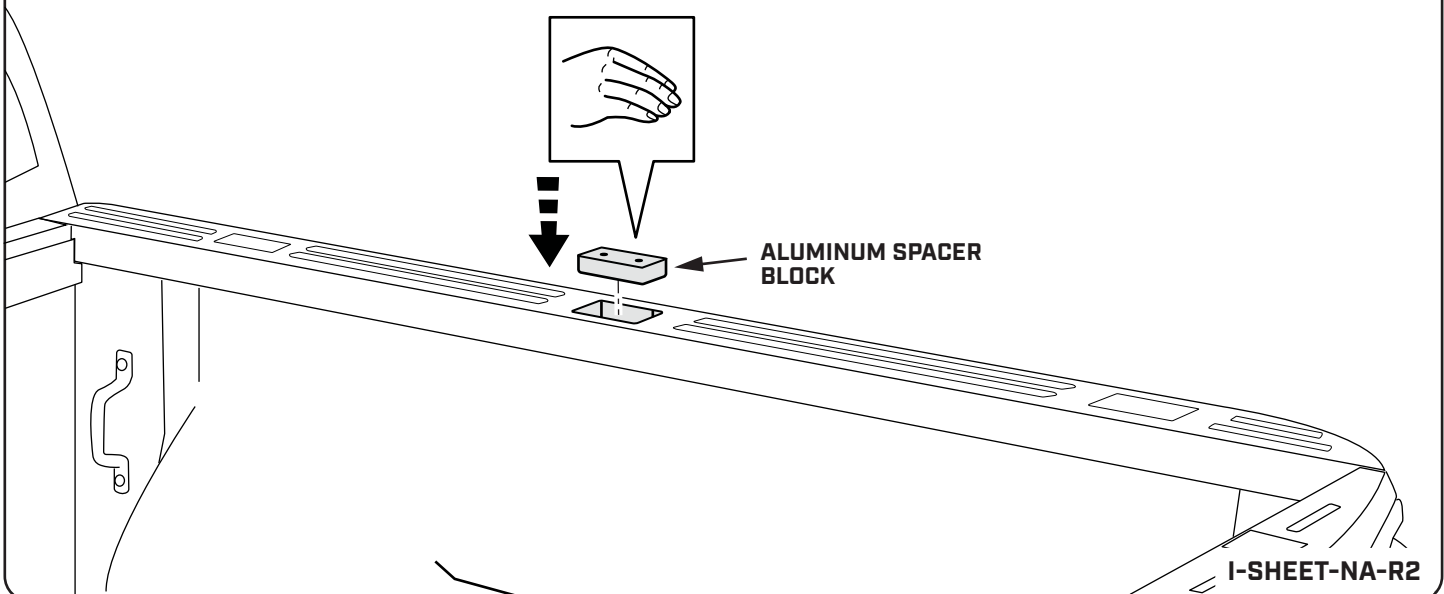
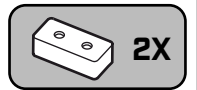

I-SHEET-NA-R2

STEP 23

INSPECT THE TRUCK BED. IF FRONT EDGE IS LOWER THAN THE SIDES, ADD FOAM SEAL TAPE TO THE FRONT EDGE OF THE BED.

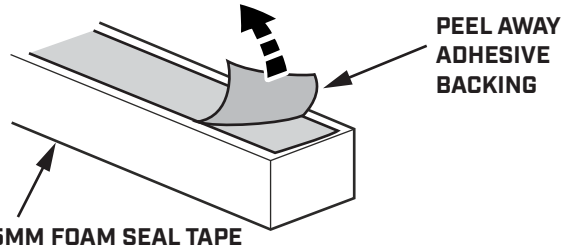
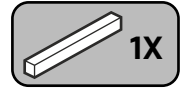

25MM X 25MM FOAM SEAL TAPE

PEEL AWAY
ADHESIVE
BACKING

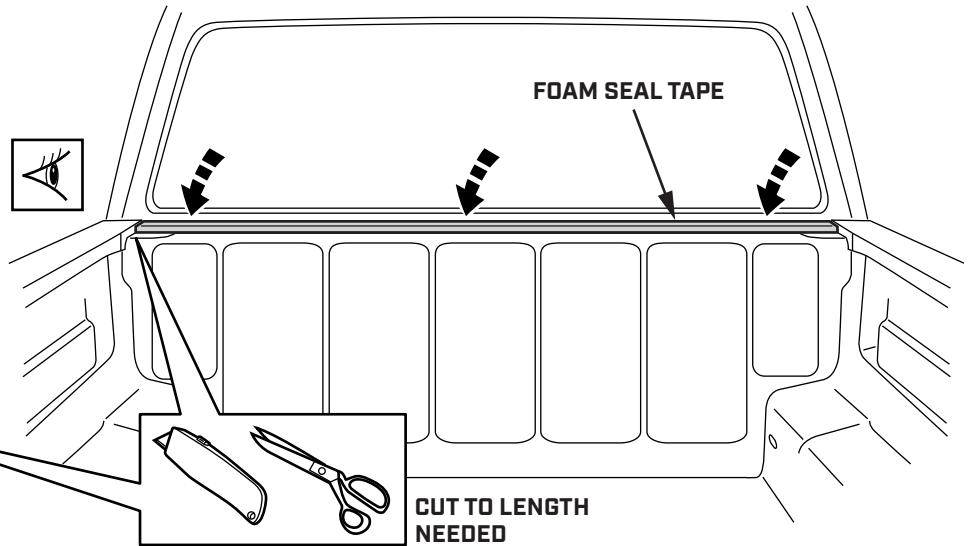

FOAM SEAL TAPE

CUT TO LENGTH
NEEDED

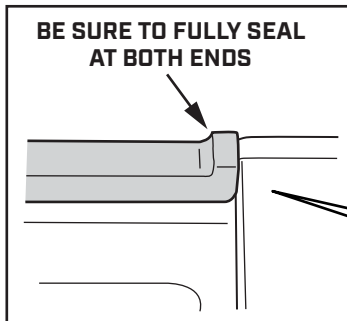

BE SURE TO FULLY SEAL
AT BOTH ENDS

STEP 24

REMOVE THE FRONT TIE DOWN HOOK FROM THE INNER WALL OF THE TRUCK BED.

POSITION THE RIGHT SIDE FRONT MOUNTING BRACKET IN THE FRONT CORNER OF THE TRUCK BED AS SHOWN.

SECURE THE BRACKET WITH THE FASTENERS AS INDICATED, HAND TIGHTEN ONLY.

REPEAT ON THE OPPOSITE SIDE OF THE VEHICLE WITH THE LEFT FRONT MOUNTING BRACKET.

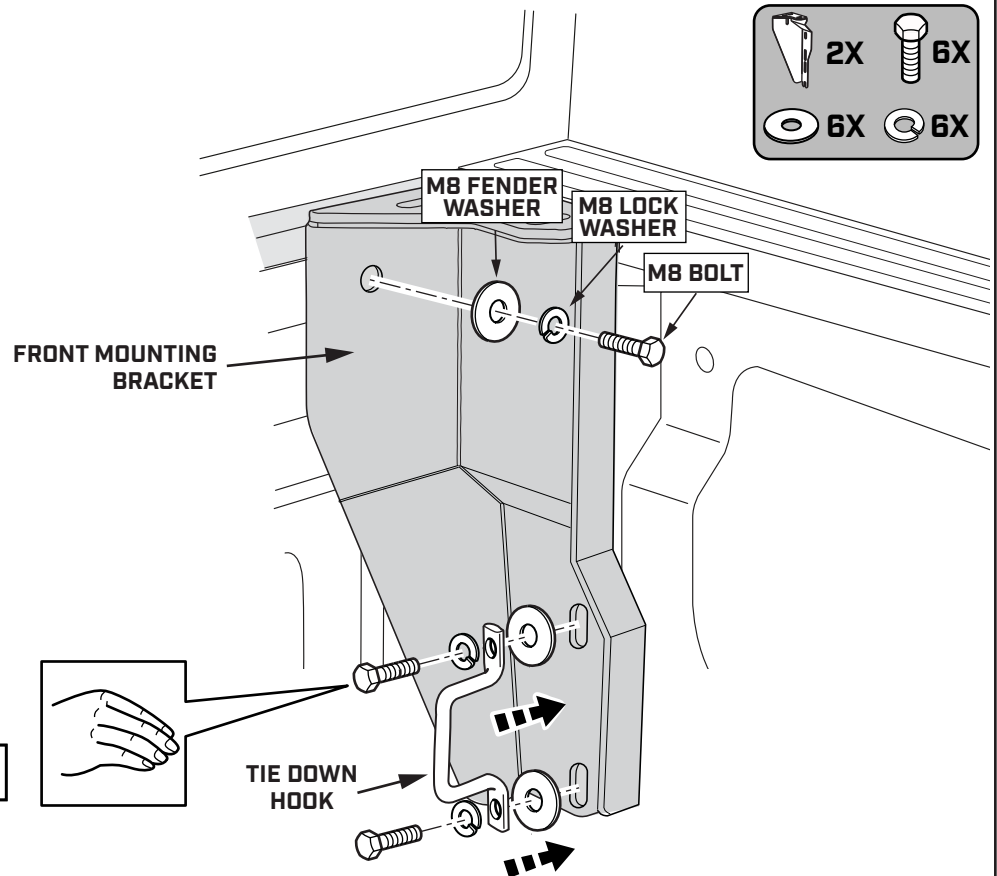
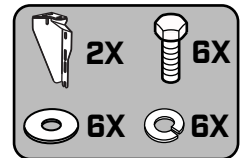

FRONT MOUNTING BRACKET

MB FENDER WASHER

MB LOCK WASHER

MB BOLT

3X

TIE DOWN HOOK

STEP 25

REMOVE THE REAR TIE DOWN HOOK FROM THE INNER WALL OF THE TRUCK BED.

POSITION THE RIGHT SIDE REAR MOUNTING BRACKET IN THE BACK CORNER OF THE TRUCK BED AS SHOWN.

SECURE THE BRACKET WITH THE FASTENERS AS INDICATED, HAND TIGHTEN ONLY.

REPEAT ON THE OPPOSITE SIDE OF THE VEHICLE WITH THE LEFT REAR MOUNTING BRACKET.

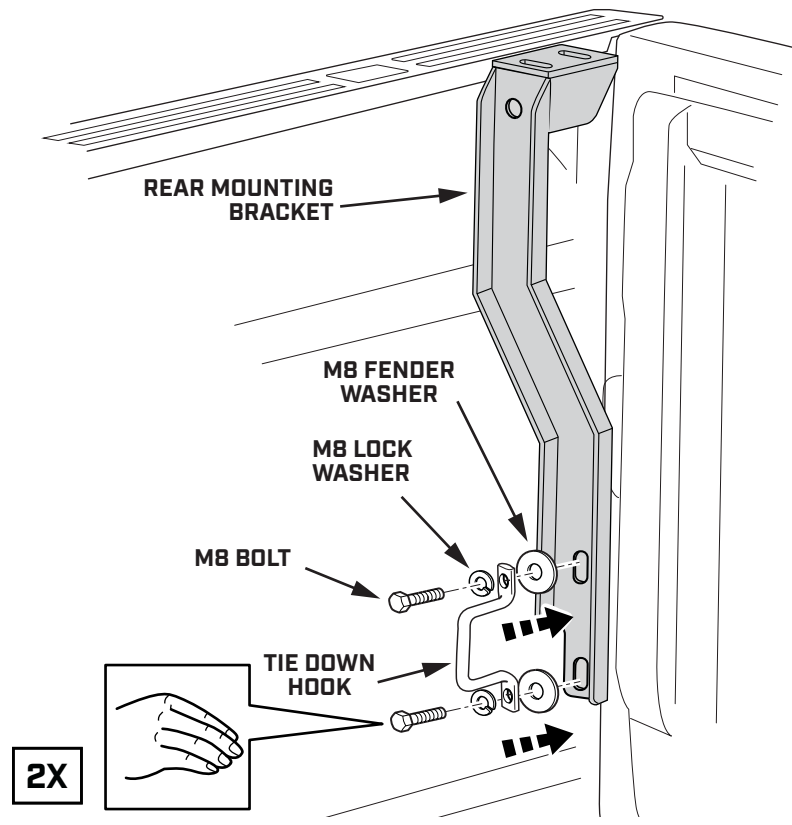
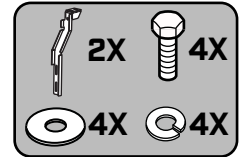

STEP 26

USE 4 PEOPLE TO LIFT THE ASSEMBLED SMARTCAP ONTO THE TRUCK BED.

TO AVOID DAMAGE TO THE D-RUBBER, DO NOT SLIDE THE SMARTCAP INTO PLACE.

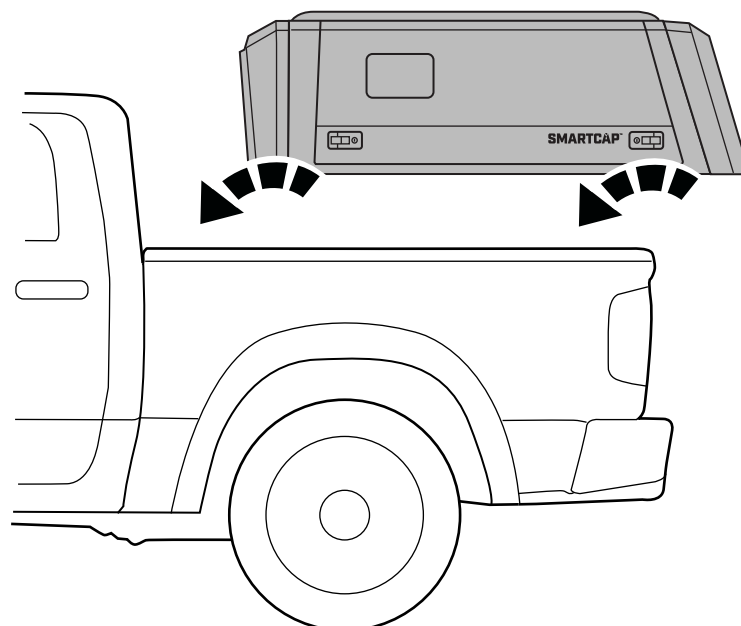

STEP 27

CHECK THAT THE SMARTCAP IS PROPERLY POSITIONED AND CENTERED ON THE TRUCK BED.

IT'S IMPORTANT THAT THE SMARTCAP IS NOT PUSHED TOO FAR FORWARD, LEAVING A GAP BETWEEN THE SMARTCAP AND THE CAB.

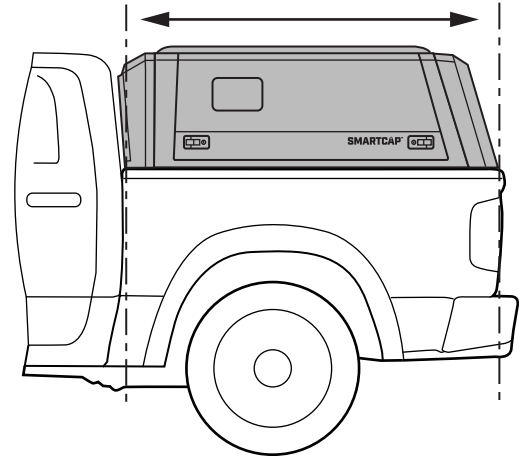
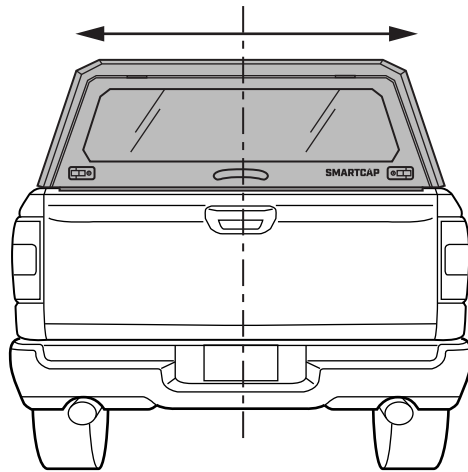
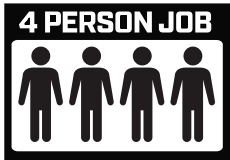

STEP 28

WALK AROUND THE TRUCK BED TO MAKE SURE THE D-RUBBER FITMENT IS CORRECT AND THAT THE RUBBER LIP IS PROPERLY TUCKED UNDERNEATH THE CAP.

CORRECT D-RUBBER ORIENTATION

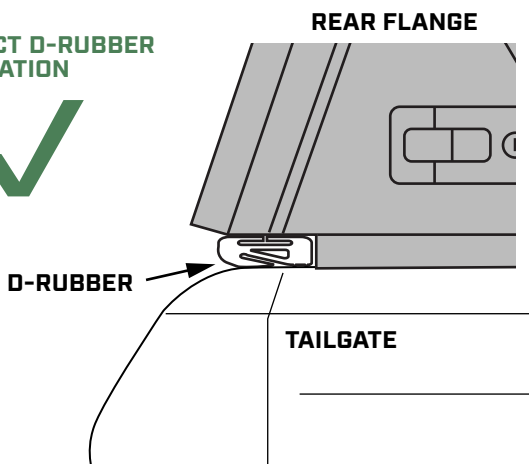

INCORRECT D-RUBBER ORIENTATION

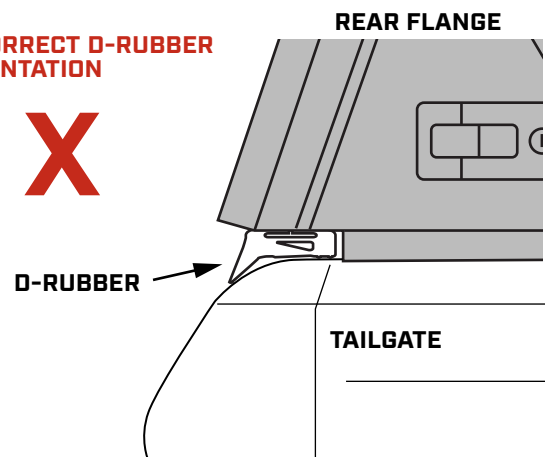

STEP 29

WITH A 5MM ALLEN KEY, LOOSELY TIGHTEN THE SMARTCAP RIGHT SIDE PANEL TO THE TOP OF THE TRUCK BED USING M8 BUTTON HEAD BOLT, M8 LOCK WASHER, AND M8 FENDER WASHER AS SHOWN BELOW.

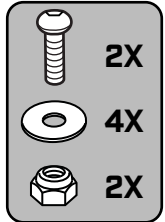

REPEAT ON THE OPPOSITE SIDE OF THE VEHICLE.

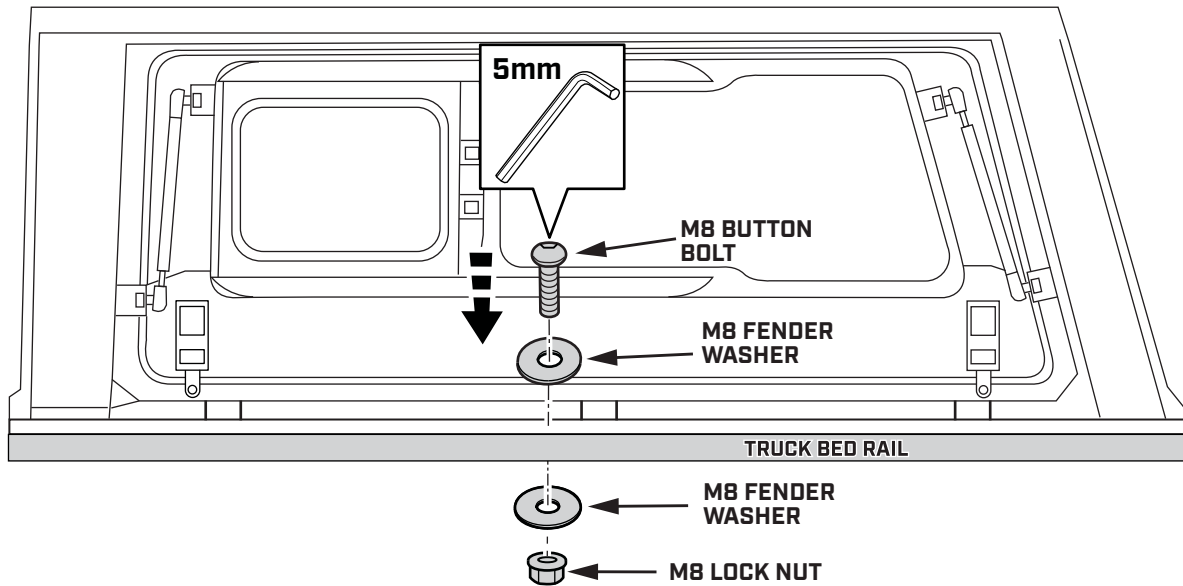

STEP 30

SECURE THE SMARTCAP TO THE RIGHT REAR MOUNTING BRACKET WITH THE FASTENERS AS INDICATED, HAND TIGHTEN ONLY.

REPEAT ON THE OPPOSITE SIDE OF THE VEHICLE WITH THE LEFT REAR MOUNTING BRACKET.

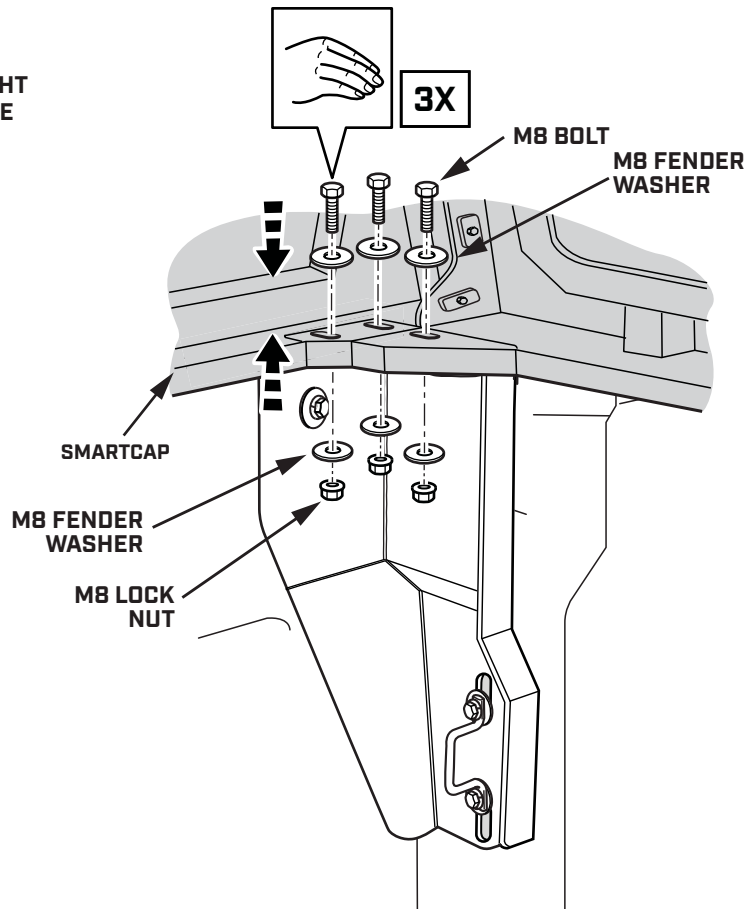
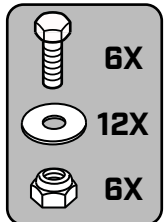

STEP 31

SECURE THE SMARTCAP TO THE RIGHT REAR MOUNTING BRACKET WITH THE FASTENERS AS INDICATED, HAND TIGHTEN ONLY.

REPEAT ON THE OPPOSITE SIDE OF THE VEHICLE WITH THE LEFT REAR MOUNTING BRACKET.

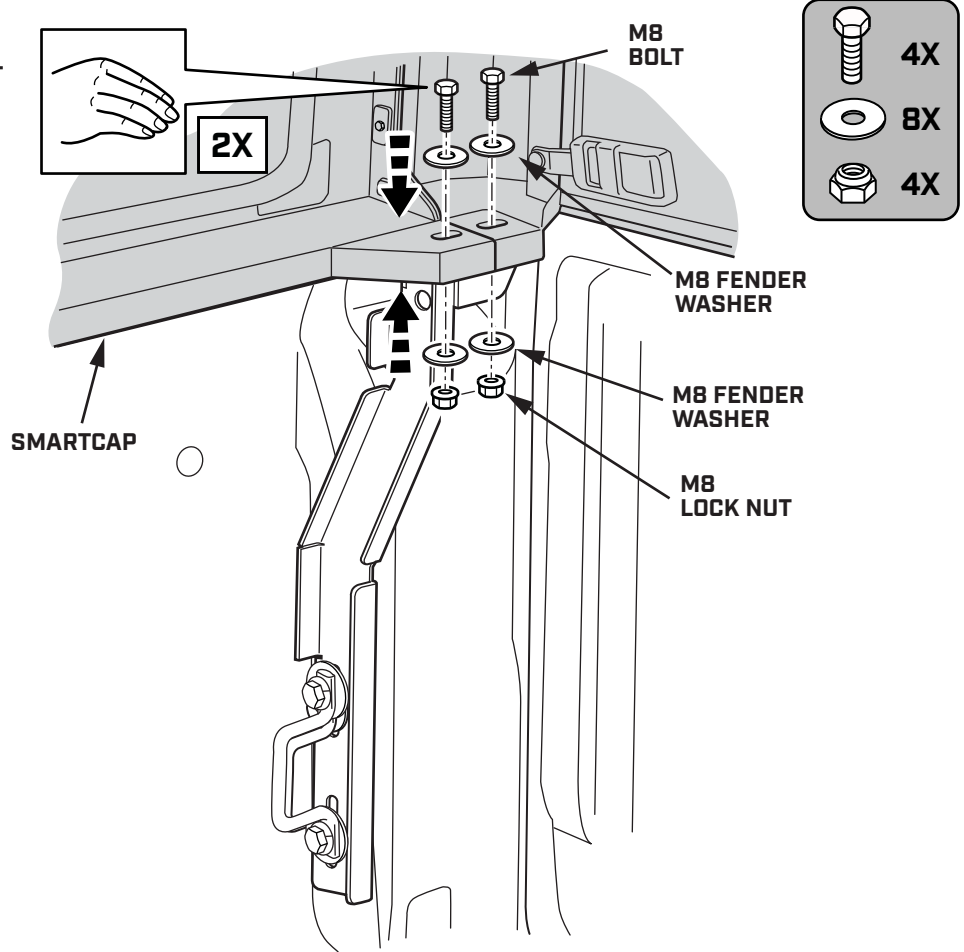

STEP 32

ONCE ALL THE FASTENERS ARE INSTALLED, PARTIALLY TIGHTEN WITH SOCKET WRENCH AS INDICATED.

PARTIALLY TIGHTEN FASTENERS ON ALL FOUR CORNERS OF THE VEHICLE.

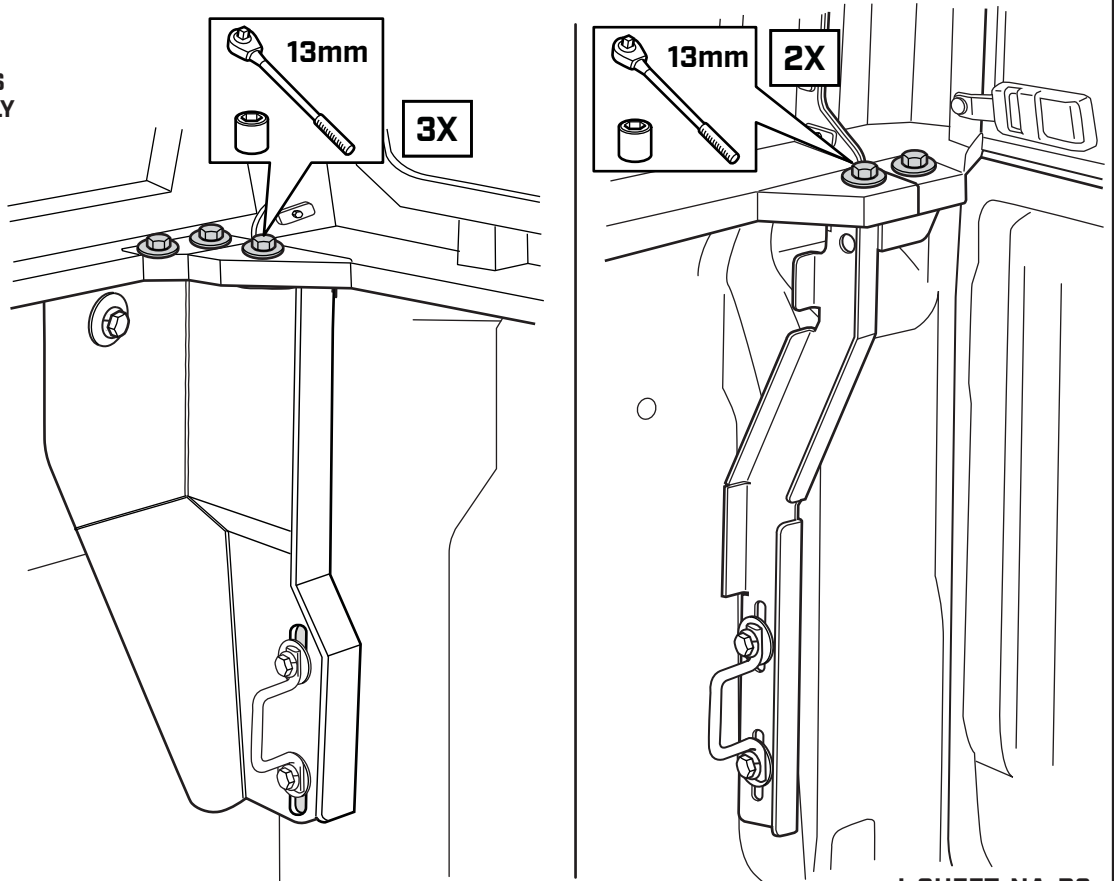

STEP 33

PRESS DOWN ON THE SMARTCAP TO ACHIEVE 2MM - 3MM COMPRESSION ON THE D-RUBBER AND CONTINUE TIGHTENING BRACKET FASTENERS WITH SOCKET WRENCH AS INDICATED.

CONTINUE TIGHTENING FASTENERS ON ALL FOUR CORNERS OF THE VEHICLE.

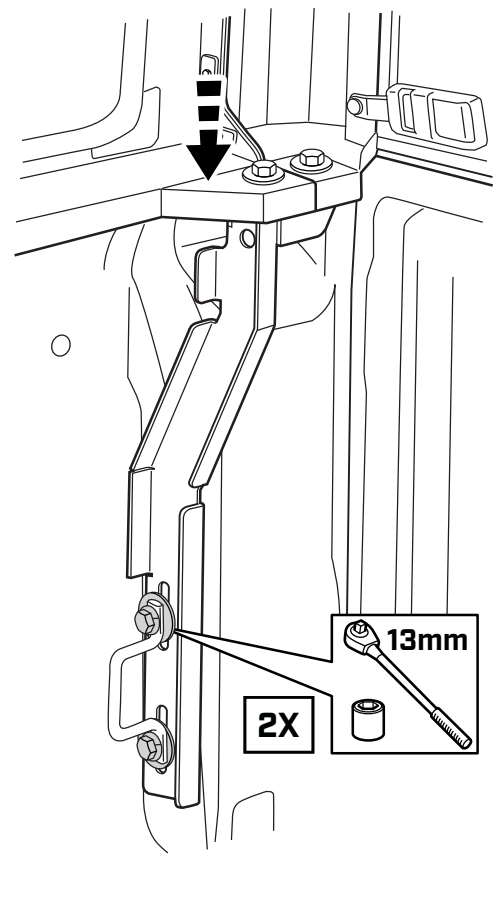
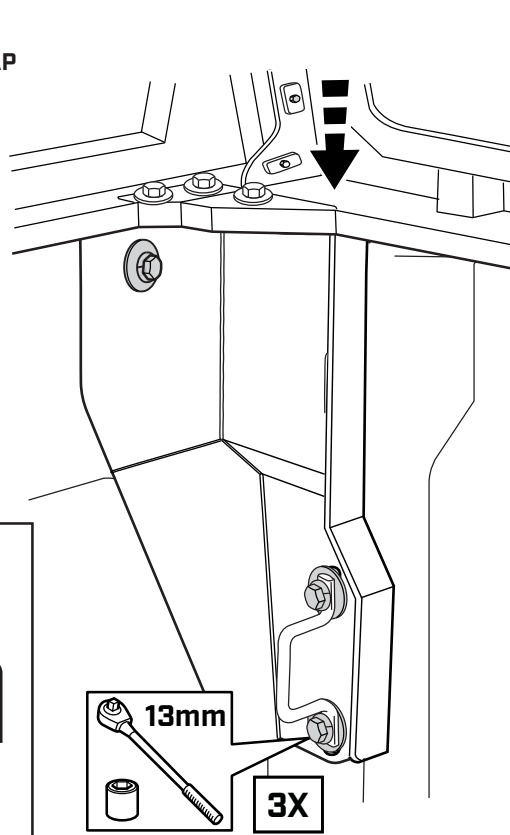
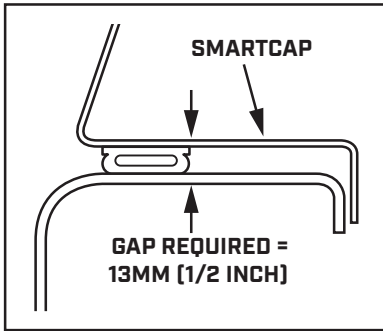

STEP 34

ONCE SMARTCAP IS POSITIONED CORRECTLY, FULLY TIGHTEN UPPER FASTENERS USING A TORQUE WRENCH AND 13MM SOCKET TO 4.4 FT. LBS [6 NEWTON METERS]

FULLY TIGHTEN UPPER FASTENERS ON ALL FOUR CORNERS OF THE VEHICLE.

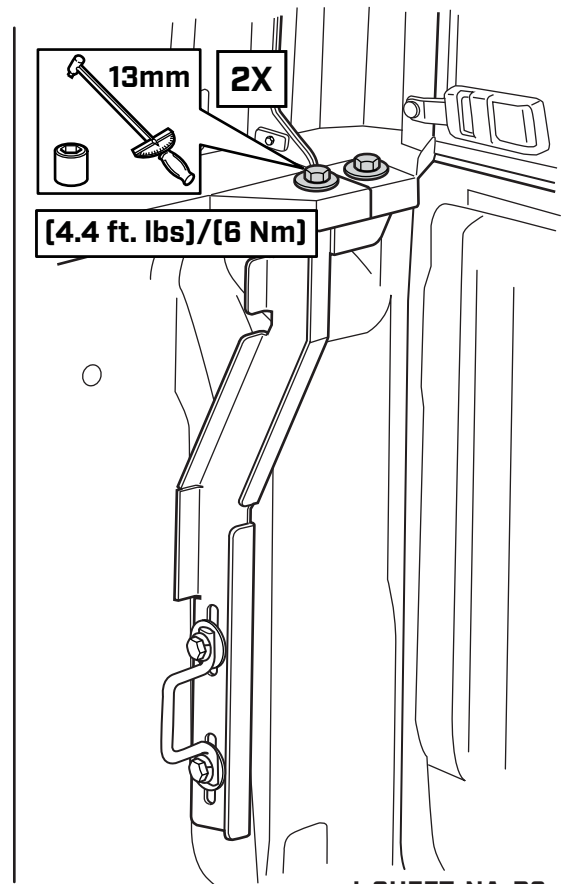
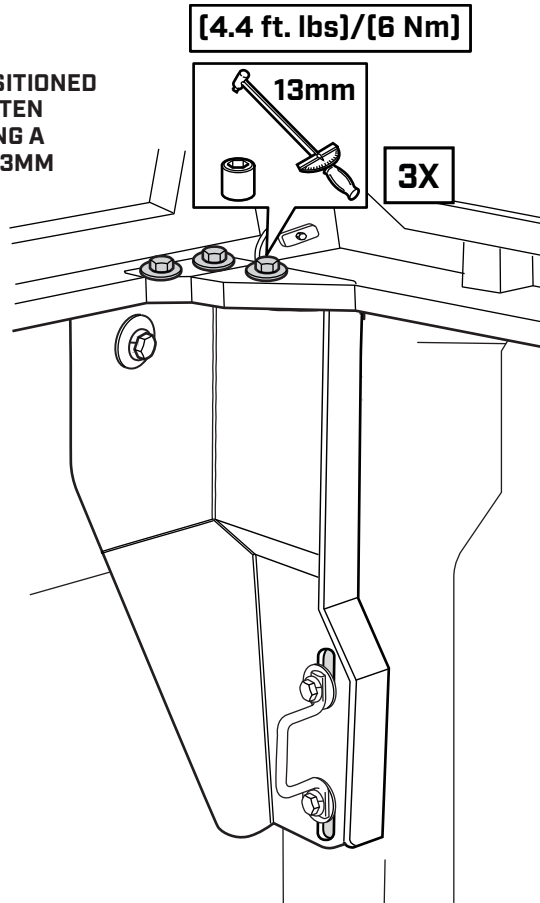

STEP 35

ONCE SMARTCAP IS POSITIONED CORRECTLY, FULLY TIGHTEN LOWER FASTENERS USING A TORQUE WRENCH AND 13MM SOCKET TO 9 FT. LBS [12.2 NEWTON METERS]

FULLY TIGHTEN LOWER FASTENERS ON ALL FOUR CORNERS OF THE VEHICLE.

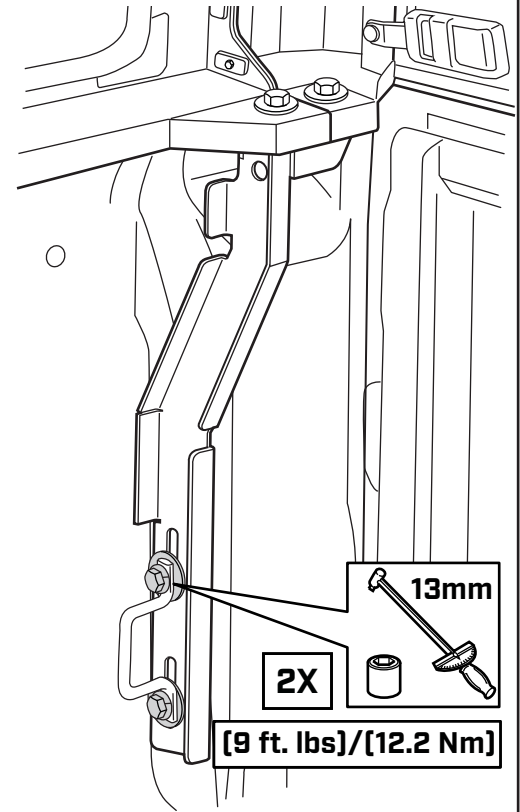
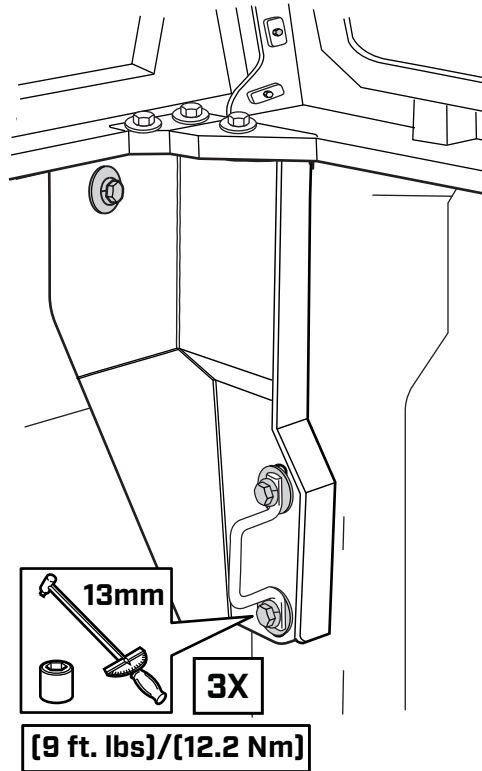

STEP 36

USING A TORQUE WRENCH WITH A 5MM HEX KEY SOCKET, TIGHTEN THE M8 BUTTON HEAD BOLT TO 4.4 FT. LBS. [6 NEWTON METERS].

REPEAT ON THE OPPOSITE SIDE OF THE VEHICLE.

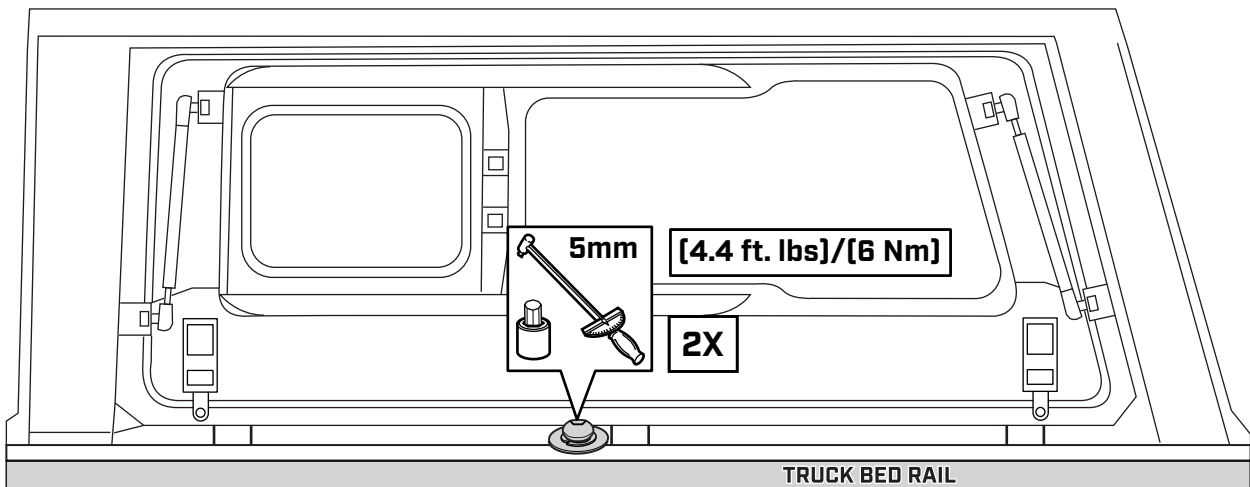

THIRD BRAKE LIGHT



IMPORTANT

- ▼ BE SURE THE VEHICLE IS TURNED OFF FOR THIS INSTALLATION.
- ▼ READ THROUGH THE ENTIRE PROCEDURE BEFORE STARTING AND FOLLOW THE STEPS CAREFULLY TO ENSURE THE THIRD BRAKE LIGHT AND TRAILER PLUG WILL FUNCTION PROPERLY.
- ▼ USE A TEST LIGHT TO CHECK FOR SUCCESSFUL INSTALLATION.

LED TAIL LIGHT HARNESS

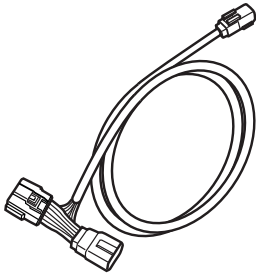

INCLUDED IN FITMENT KIT

INCANDESCENT TAIL LIGHT HARNESS

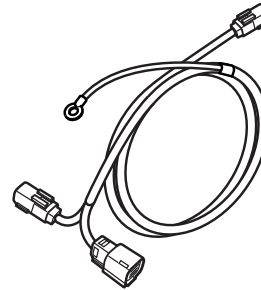

IF YOUR RANGER IS EQUIPPED WITH INCANDESCENT TAILLIGHTS, PLEASE CONTACT SUPPORT.NA@SMARTCAP.COM TO RECEIVE THE APPROPRIATE HARNESS.

STEP 37

UNTIE THE THIRD BRAKE LIGHT EXTENSION HARNESS FROM WHERE IT IS ATTACHED TO THE SMARTCAP AT THE RIGHT REAR CORNER.

NOTE: THE CONNECTOR ON THE END OF THE HARNESS WILL NEED TO BE DE-PINNED IN ORDER TO ROUTE THROUGH THIS HOLE.

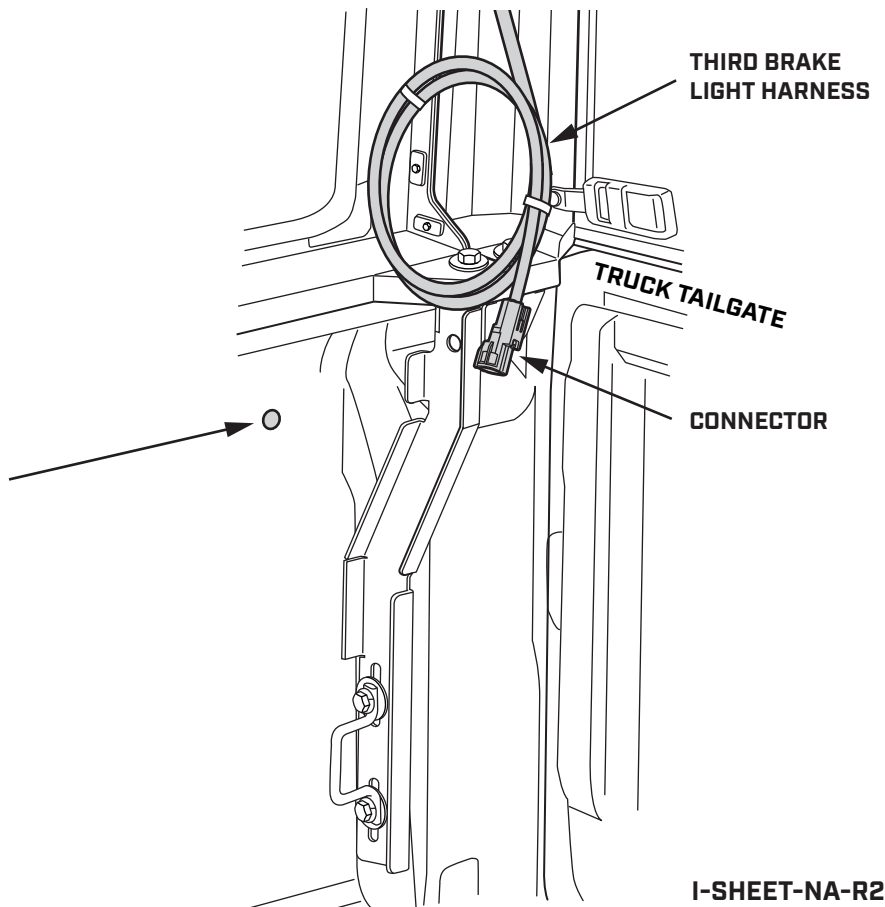

I-SHEET-NA-R2

STEP 38

DE-PIN CONNECTOR.



TAKE NOTE OF WIRE ORIENTATION

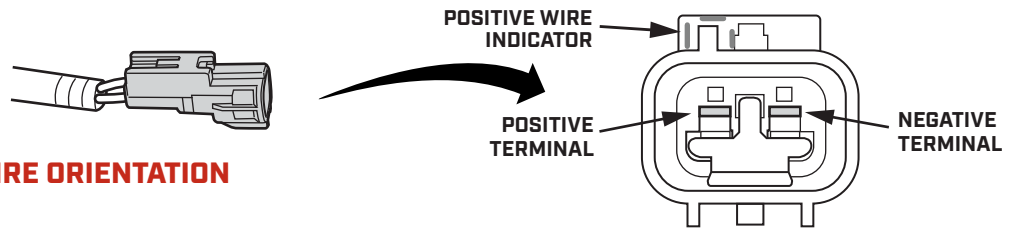

A USE A SCREWDRIVER TO PULL THE LOCK CLIP FORWARD.

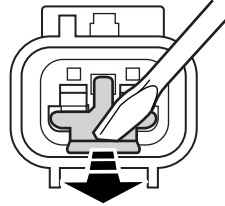

B USE A PIN TOOL TO PRESS DOWN ON THE WIRE RELEASE TABS.

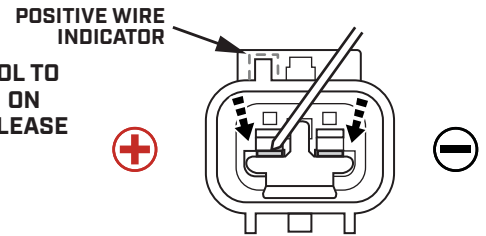

C WHILE PRESSING DOWN ON THE RELEASE TABS, REMOVE EACH OF THE WIRES FROM THE CONNECTOR.

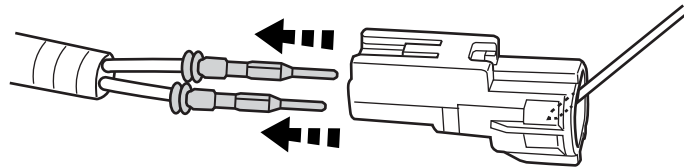

STEP 39

ROUTE THE THIRD BRAKE LIGHT EXTENSION HARNESS THROUGH THE HOLE AND DOWN TOWARDS THE INSIDE REAR BUMPER.



BE SURE NOT TO DAMAGE TERMINALS

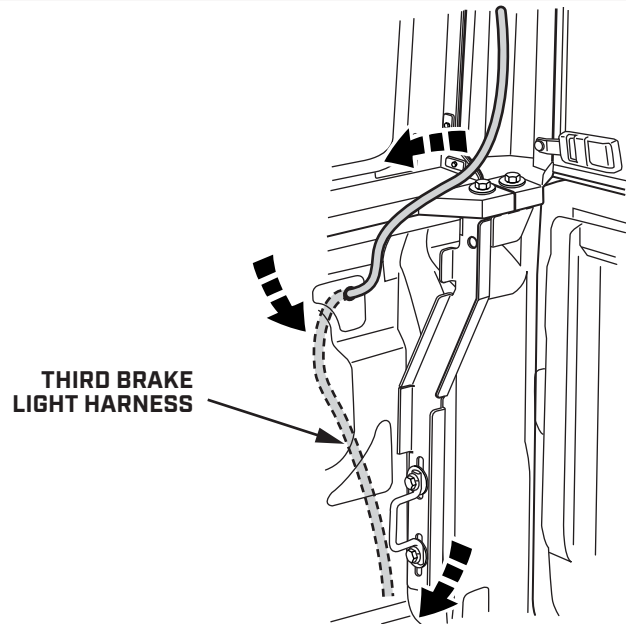

STEP 40

RE-ATTACH THE CONNECTOR TO THE THIRD BRAKE LIGHT HARNESS IN THE SAME FASHION AS IT WAS REMOVED.

SEE STEP 37

POSITIVE WIRE INDICATOR

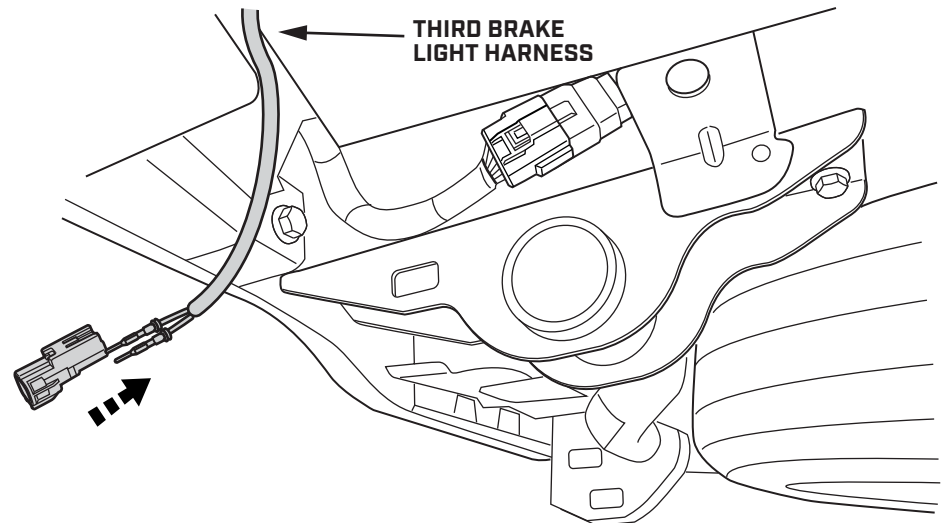
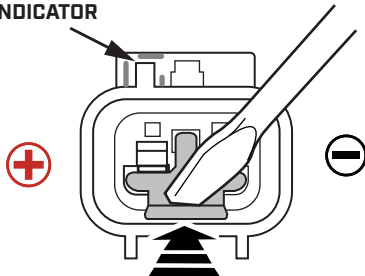

I-SHEET-NA-R2

STEP 41

WITH LED TAILLIGHTS

CONNECT THE LED T-HARNESS TO THE 2-PIN CONNECTOR AT THE END OF THE BRAKE LIGHT EXTENSION HARNESS.

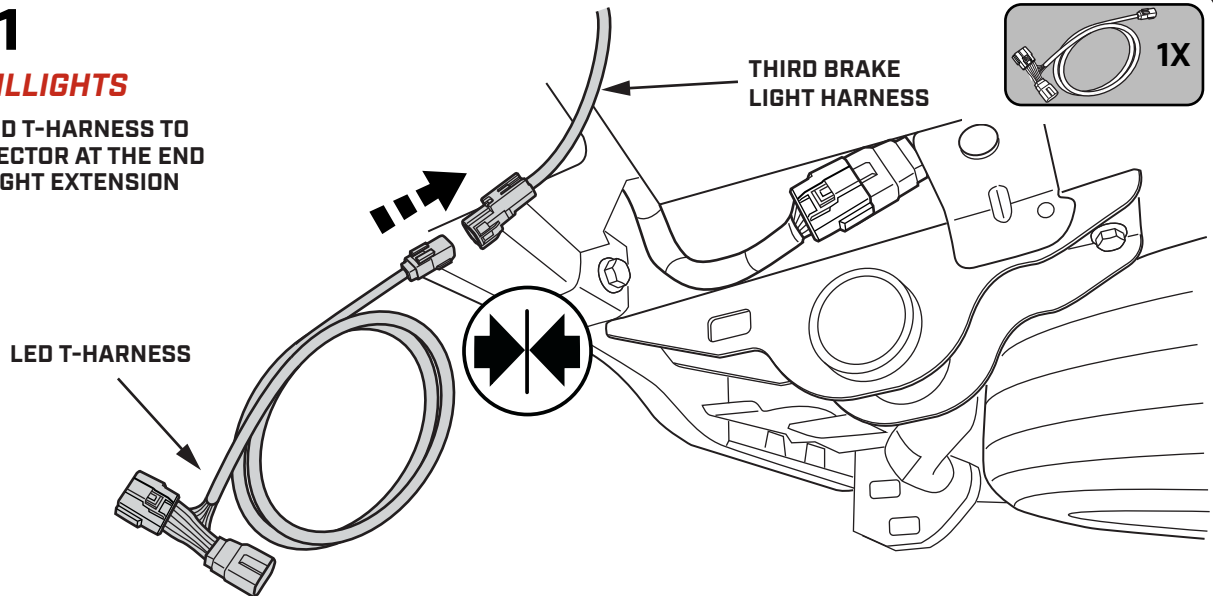

STEP 42

WITH LED TAILLIGHTS

LOCATE THE 16-PIN CONNECTOR ON THE PASSENGER SIDE FRAME RAIL AND DISCONNECT IT.

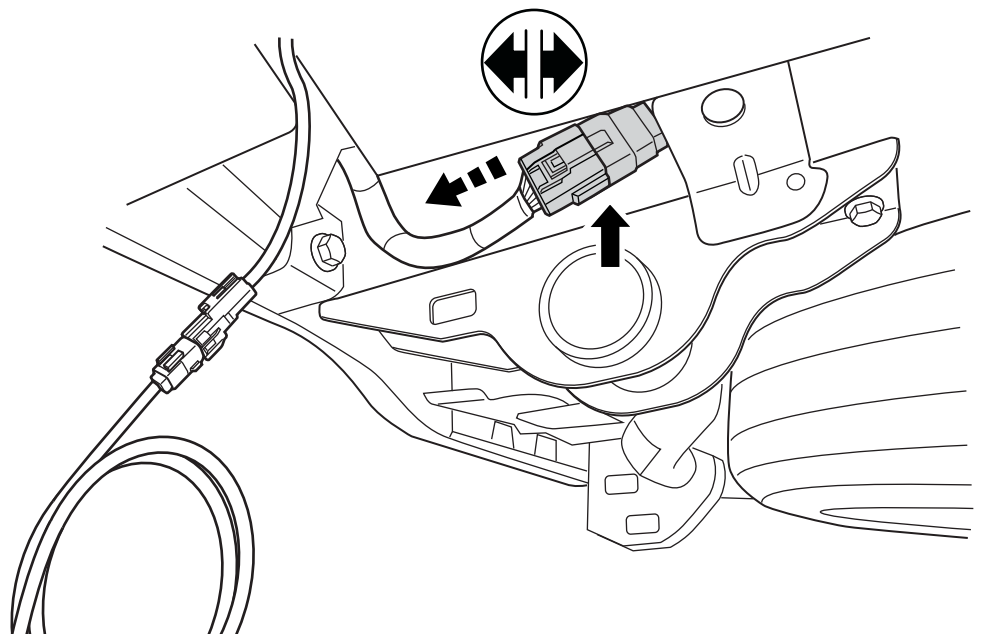

STEP 43

WITH LED TAILLIGHTS

CONNECT THE T-HARNESS FEMALE CONNECTOR TO THE VEHICLE HARNESS MALE CONNECTOR.

CONNECT THE T-HARNESS MALE CONNECTOR TO THE VEHICLE HARNESS FEMALE CONNECTOR.

BUNDLE THE EXTRA T-HARNESS LENGTH UNDER THE VEHICLE AND SECURE WITH CABLE TIES

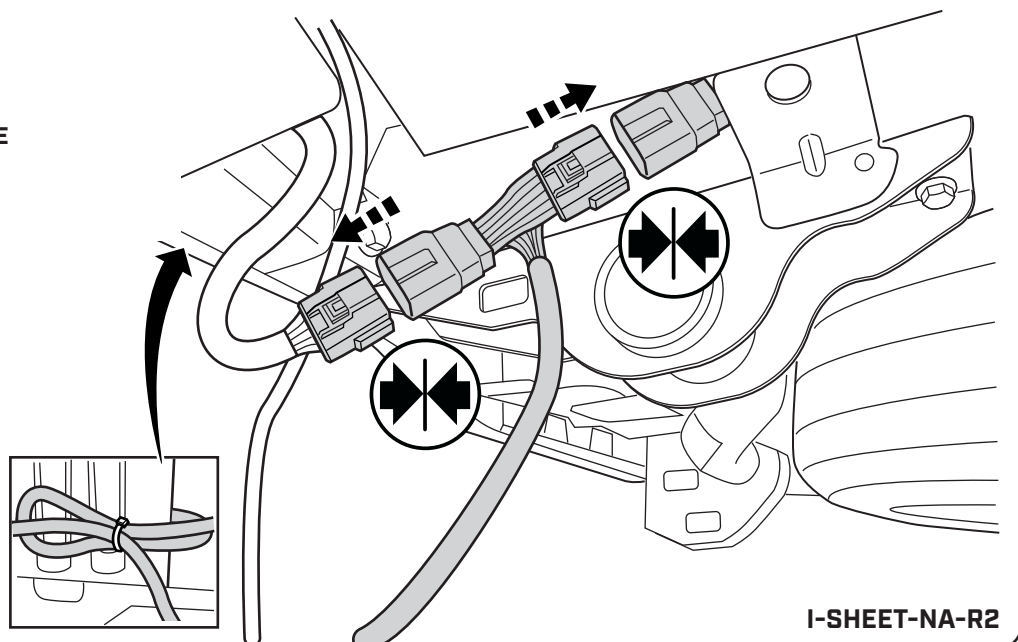

STEP 44

INCANDESCENT TAILLIGHTS

CONNECT THE INCANDESCENT T-HARNESS TO THE 2-PIN CONNECTOR AT THE END OF THE BRAKE LIGHT EXTENSION HARNESS.

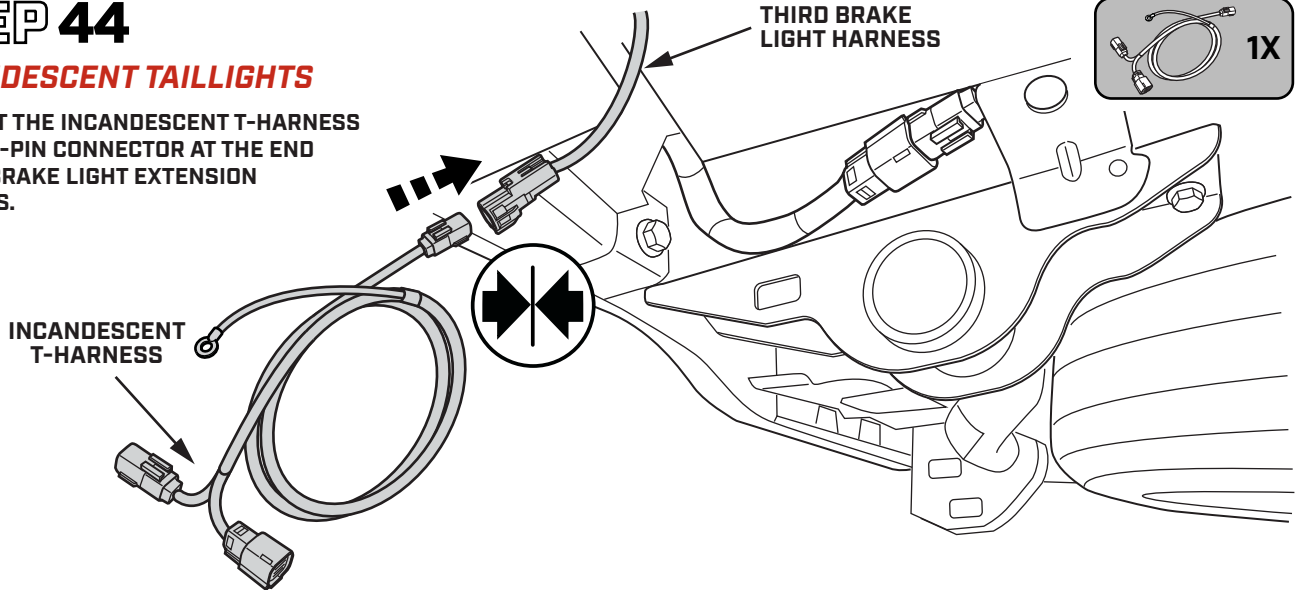

STEP 45

INCANDESCENT TAILLIGHTS

LOCATE THE 6-PIN CONNECTOR ON THE PASSENGER SIDE FRAME RAIL AND DISCONNECT IT.

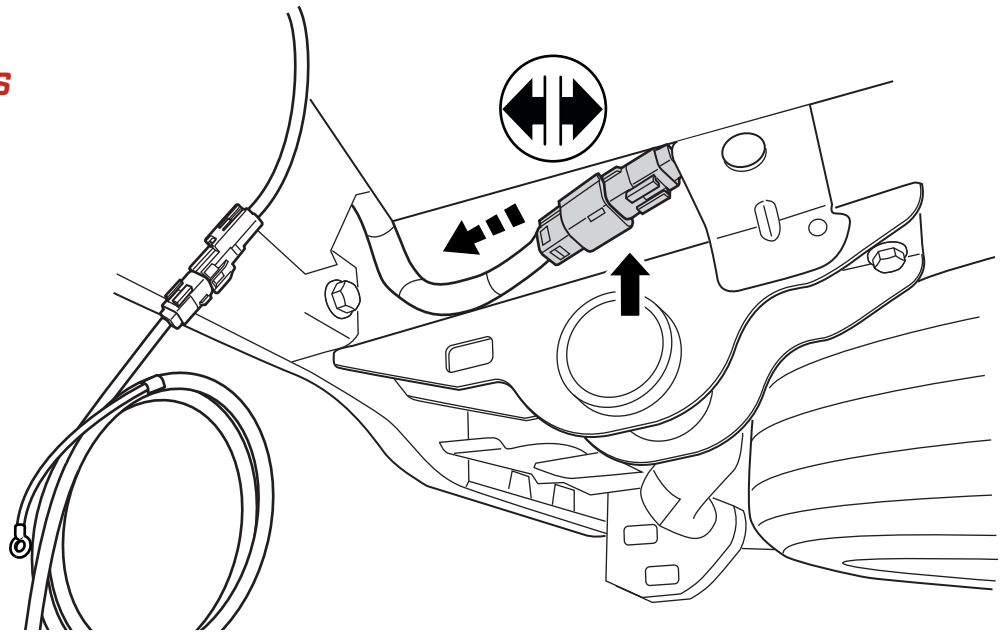

STEP 46

INCANDESCENT TAILLIGHTS

CONNECT THE T-HARNESS FEMALE CONNECTOR TO THE VEHICLE HARNESS MALE CONNECTOR.

CONNECT THE T-HARNESS MALE CONNECTOR TO THE VEHICLE HARNESS FEMALE CONNECTOR.

BUNDLE THE EXTRA T-HARNESS LENGTH UNDER THE VEHICLE AND SECURE WITH CABLE TIES

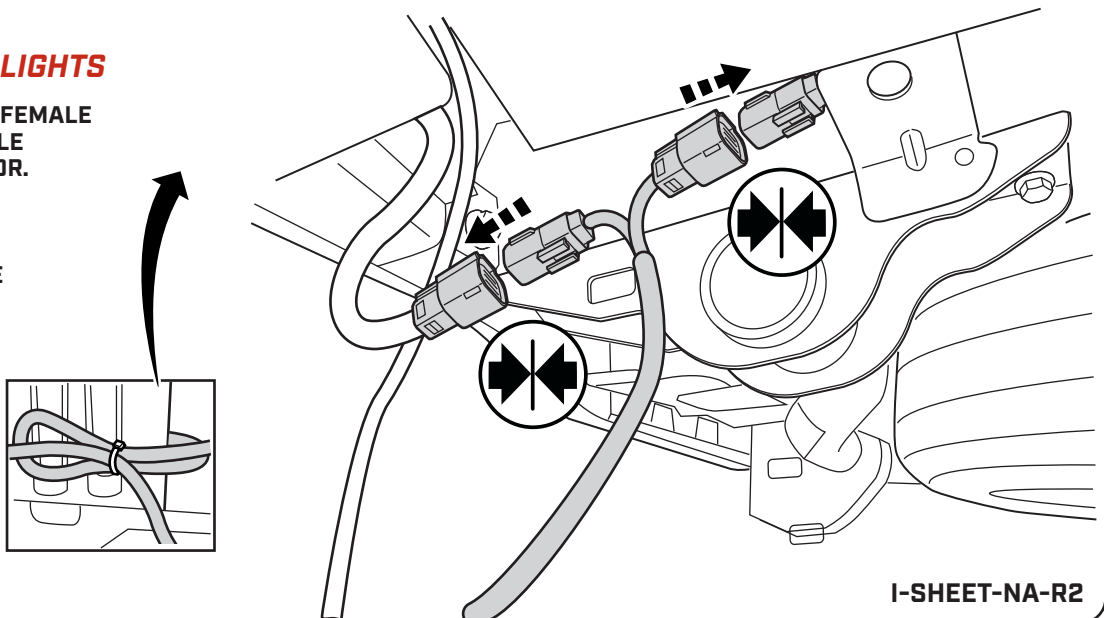

I-SHEET-NA-R2

STEP 47

INCANDESCENT TAILLIGHTS

SECURE THE GROUND WIRE ON THE T-HARNESS TO THE CHASSIS AT A SUITABLE LOCATION UNDER THE VEHICLE.

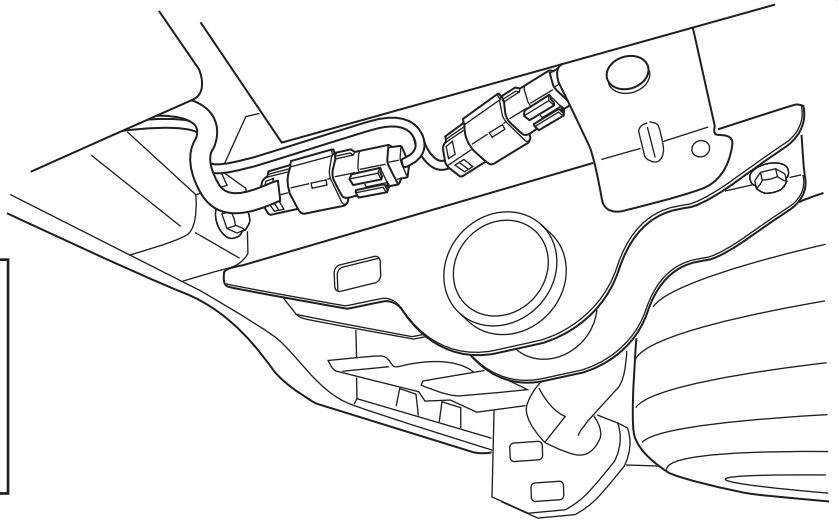
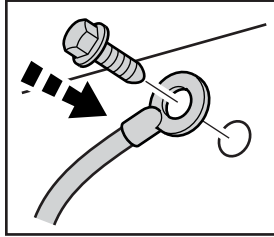

STEP 48

START THE TRUCK. NOTE THAT ON SOME MODELS, IT MAY TAKE UP TO 30 SECONDS FOR THE VEHICLE TO DETECT THE NEW CONNECTION. CHECK THE BRAKE LIGHTS AND TURN SIGNALS TO BE SURE THEY ARE FUNCTIONING PROPERLY.

ONCE YOU HAVE CONFIRMED THAT THE LIGHTS ARE WORKING CORRECTLY, SECURE THE HARNESS WITH CABLE TIES. **BE SURE NOT TO INTERFERE WITH ANY MOVING PARTS ON THE VEHICLE.**

DUAL RELEASE LATCHES



IMPORTANT

- ▼ THE LOCK IS DESIGNED SO THAT IT CAN BE OPENED FROM THE INSIDE OF THE CAP, WHETHER IN A LOCKED OR UNLOCKED STATE.

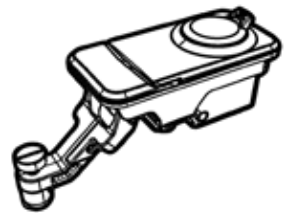

UNLOCKING & OPENING (FROM OUTSIDE)

INSERT KEY INTO LOCK BARREL AND TURN TO UNLOCK. REMOVE THE KEY AND PRESS THE EXTERNAL RELEASE BUTTON TO OPEN THE SPRING LOADED LATCH.

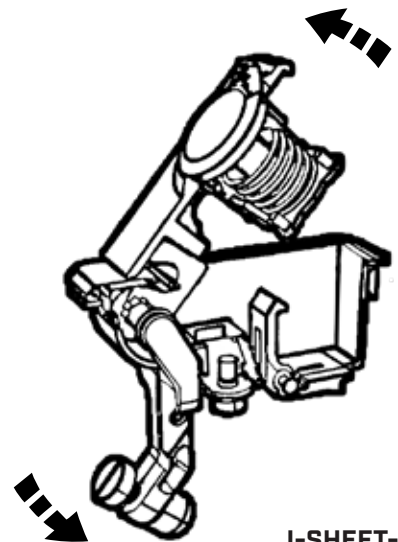
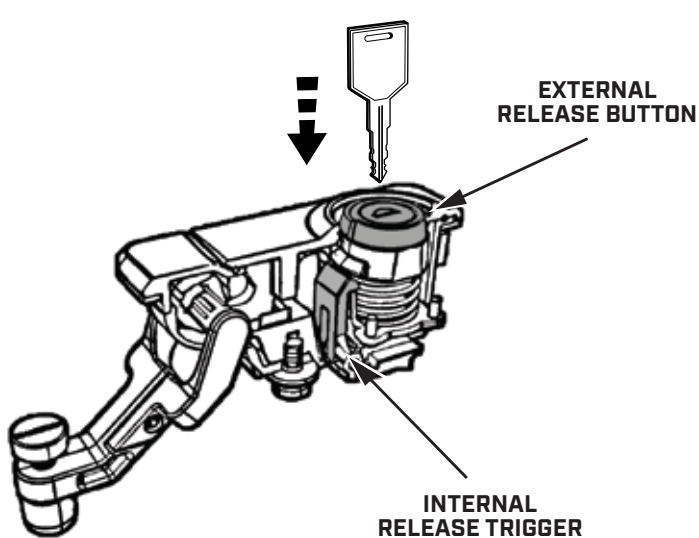

I-SHEET-NA-R2

UNLOCKING & OPENING (FROM INSIDE)

PRESS THE INTERNAL RELEASE BUTTON TO OPEN THE SPRING LOADED LATCH.

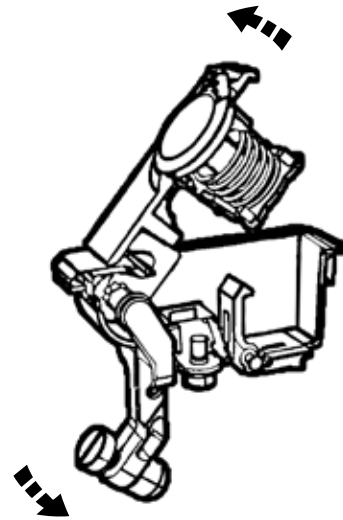
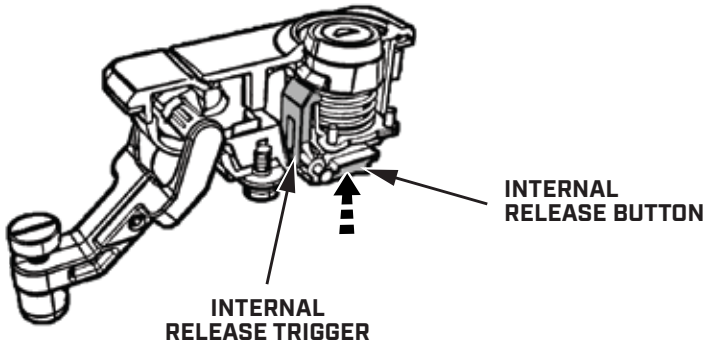

CLOSING & LOCKING

PRESS THE LATCH PLATE INTO THE CLOSED POSITION UNTIL THE BUTTON CYLINDER IS SECURED IN PLACE BY THE INTERNAL RELEASE TRIGGER.

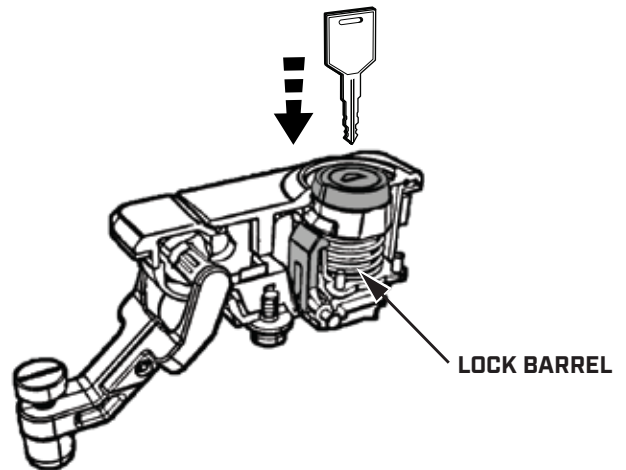
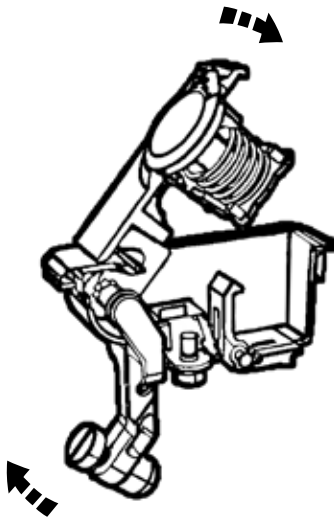

SMARTCAP[®]

THANKS FOR YOUR PURCHASE.
PLEASE LET US KNOW IF YOU HAVE ANY QUESTIONS.

SMARTCAP.COM

SUPPORT.NA@SMARTCAP.COM - NORTH AMERICA
SUPPORT.SA@SMARTCAP.COM - REST OF WORLD



I-SHEET-NA-R2