

SMARTCAP®

INSTRUCTION GUIDE

GM CANYON/COLORADO EDITION

2023-CURRENT (3rd Generation)

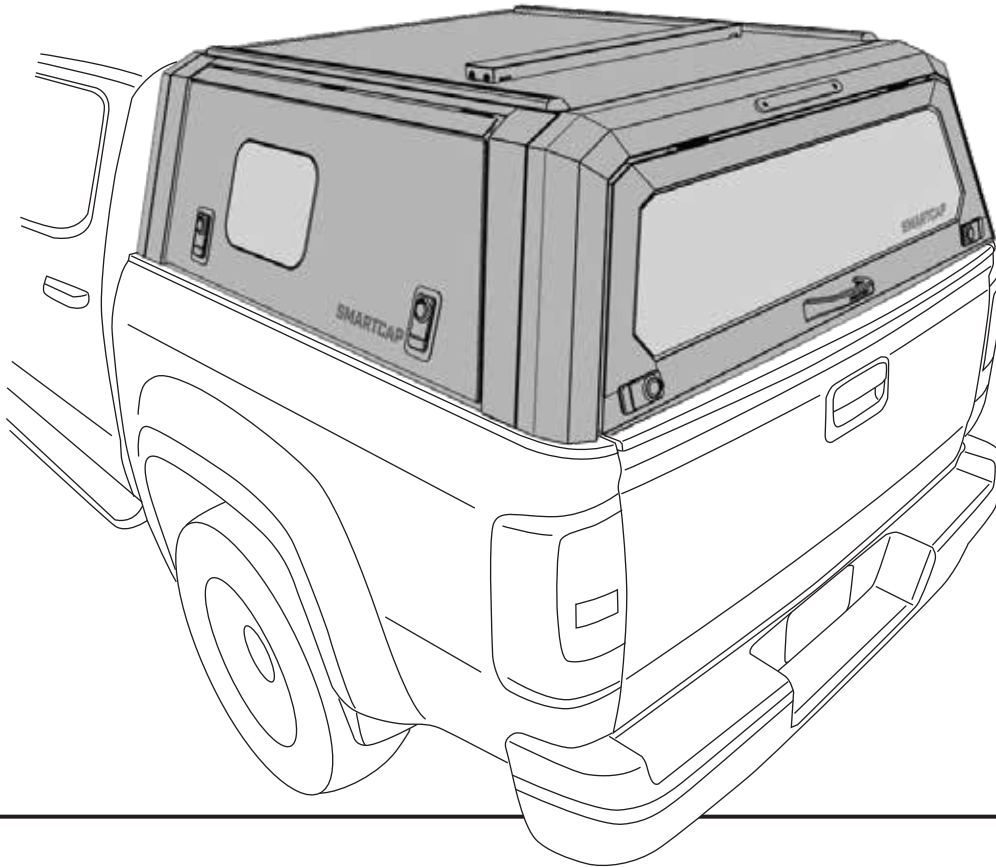

- ▼ **PREPARE A CLEAN WORK AREA.**
- ▼ **WE RECOMMEND A MINIMUM OF 2 PEOPLE FOR ASSEMBLY AND 4 PEOPLE FOR INSTALLATION.**
- ▼ **ENSURE THE REQUIRED TOOLS ARE PRESENT AND ALL HARDWARE CONTENTS ARE ACCOUNTED FOR.**
- ▼ **NEVER USE ACETONE OR THINNERS ON PAINTED PARTS.**
- ▼ **READ THROUGH THE ENTIRE INSTRUCTION GUIDE BEFORE STARTING THIS PROCEDURE AND FOLLOW THE STEPS CAREFULLY TO AVOID ANY DAMAGE TO THE COMPONENTS OR THE VEHICLE.**

SMARTCAP.COM - SUPPORT.NA@SMARTCAP.COM - NORTH AMERICA



I-SHEET-NA-C3

TOOLS REQUIRED

Combination
Wrench

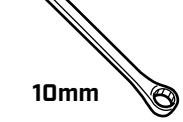

10mm

Torque
Wrench



10mm Socket

Allen Key



6mm Allen Key
6mm Hex Socket

Utility
Knife



Scissors



Gel
Super Glue



IMPORTANT

- ▼ USE ONLY THE TOOLS RECOMMENDED ABOVE.
- ▼ USE ONLY THE HARDWARE PROVIDED IN THIS KIT.
- ▼ ASSISTANCE WILL BE NEEDED FOR THIS INSTALLATION.
FOUR PEOPLE ARE RECOMMENDED TO LIFT THE SMARTCAP ONTO THE VEHICLE.
- ▼ AVOID PINCHING OR CRUSHING HANDS AND FINGERS.
- ▼ INSPECT ALL KIT COMPONENTS FOR DAMAGE BEFORE ASSEMBLY.
- ▼ NEVER USE ACETONE OR THINNERS ON PAINTED PARTS.

COMPONENTS

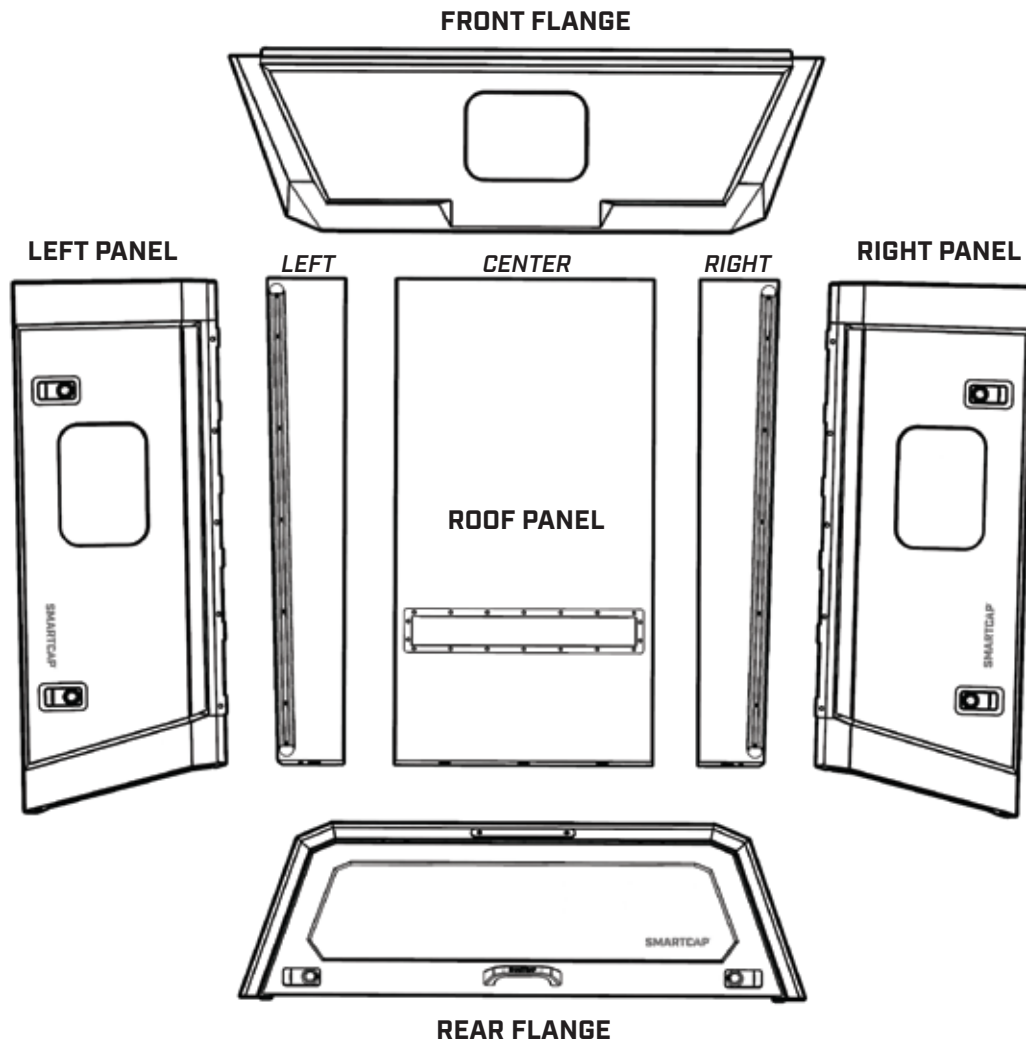

I-SHEET-NA-C3

ASSEMBLY HARDWARE

FITMENT KIT

M6 BOLT

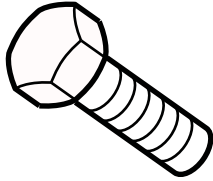

42X

**FASTENER
BLOCK CLAMP**

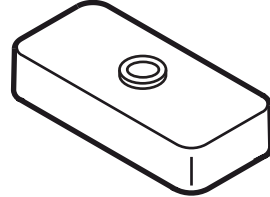

42X

**M6
LOCK WASHER**

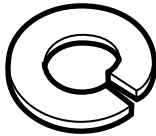

42X

**FASTENER
BLOCK**

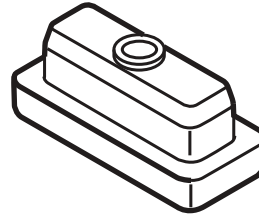

42X

D - RUBBER



1X

SPARE PARTS

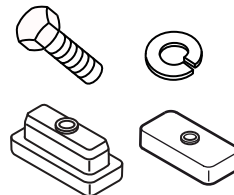

2X

**M6
FENDER WASHER**

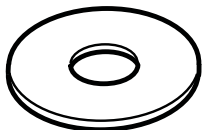

10X

**M6
LOCK NUT**

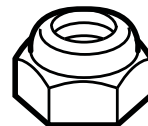

10X

STEP 1



IMPORTANT

▼ BE SURE TO REMOVE ALL SEVEN PANELS FROM THEIR PACKAGING AND INSPECT THE PAINTED SURFACES PRIOR TO ASSEMBLY, AS SMARTCAP WILL NOT ACCEPT WARRANTY CLAIMS AFTER ASSEMBLY IS COMPLETED. IF MANUFACTURING IMPERFECTIONS OR SHIPPING DAMAGES ARE FOUND, DO NOT CONTINUE WITH THE ASSEMBLY PROCESS AND CONTACT SUPPORT.NA@SMARTCAP.COM

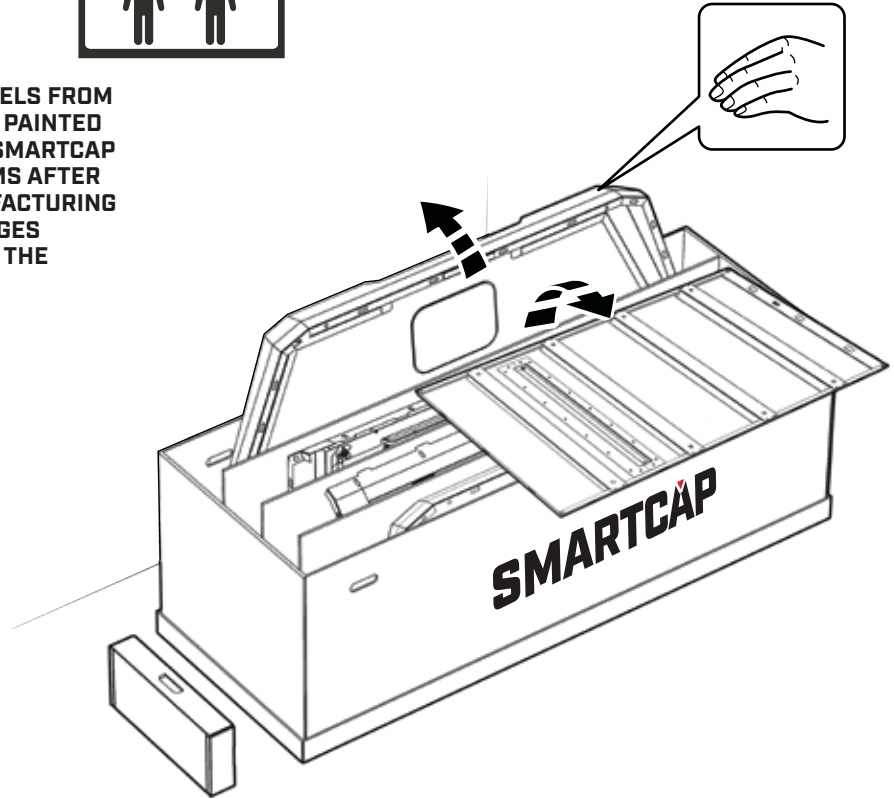

STEP 2

REMOVE THE FOUR CORNER STIFFENERS AND ONE OF THE CARDBOARD DIVIDERS TO BE USED AS A PROTECTIVE SURFACE DURING ASSEMBLY.

UNFOLD THE CARDBOARD DIVIDER AND PLACE IT WHERE YOU PLAN TO ASSEMBLE YOUR CAP.

PLACE THE FOUR CORNER STIFFENERS AS SHOWN BELOW.

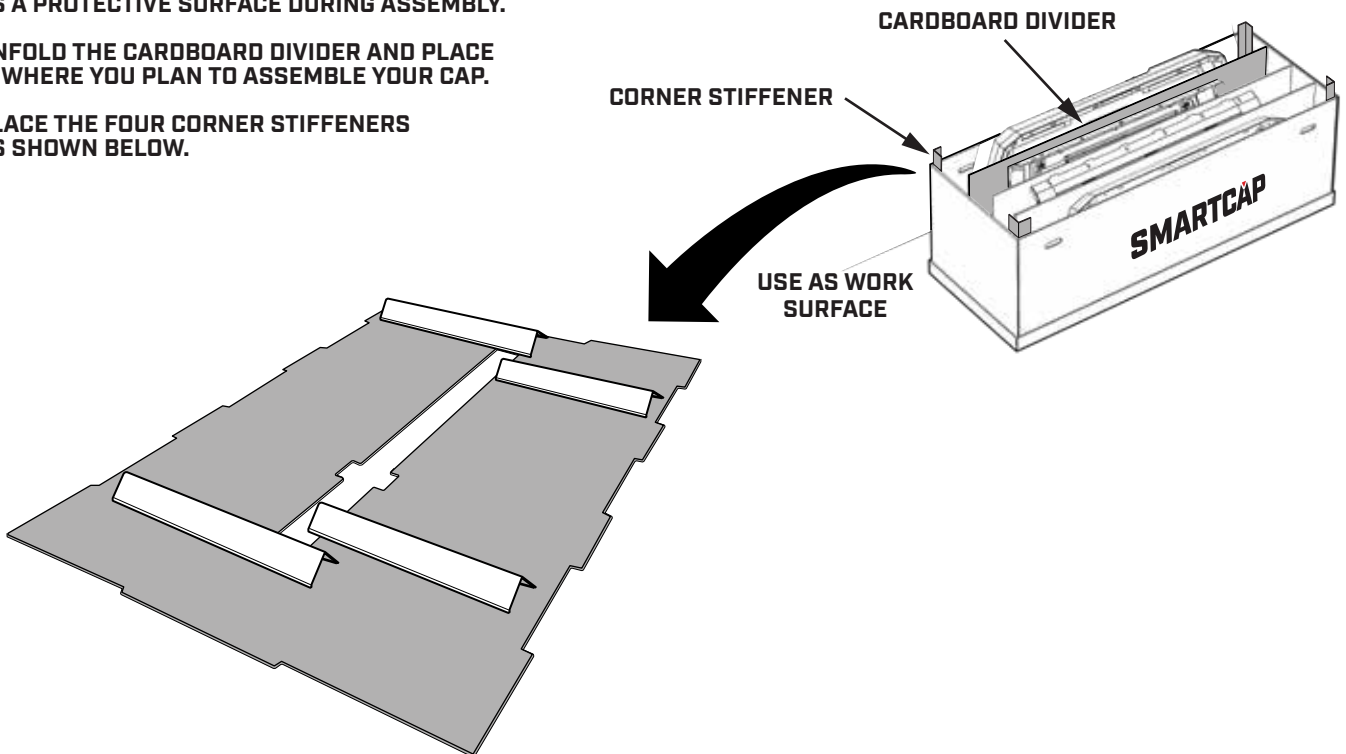

I-SHEET-NA-C3

STEP 3

PLACE THE ROOF PANELS ON TOP OF THE CORNER STIFFENERS, WITH THE BOTTOM OF THE ROOF PANELS FACING UP.

ALIGN THE PANELS SO THAT THE PROFILE OF THE FRONT AND REAR EDGES MATCH.

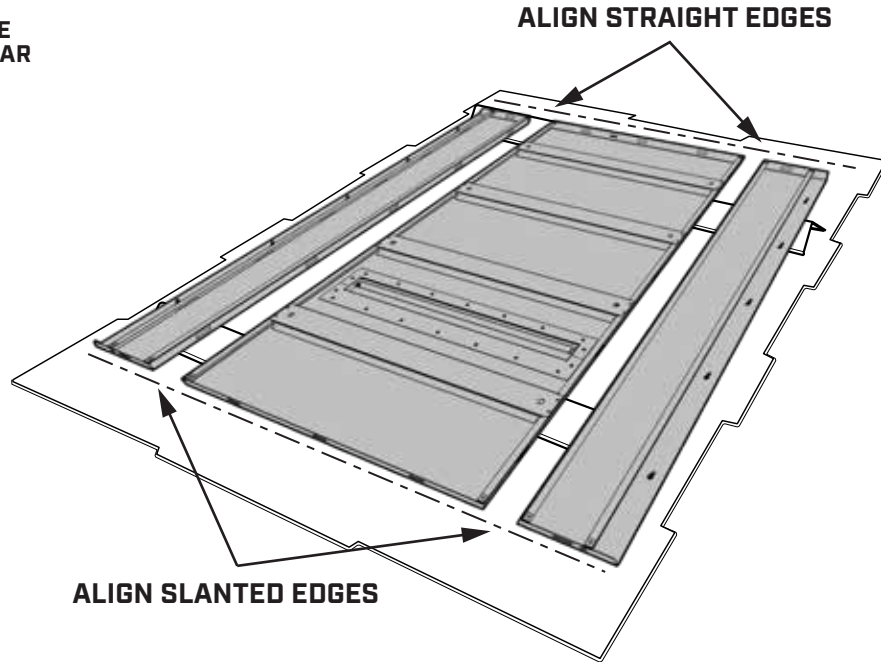

STEP 4

ASSEMBLE THE FASTENER BLOCKS TO THE ROOF PANELS USING A TORQUE WRENCH AND 10MM SOCKET TO 3.7 FT. LBS [5 NEWTON METERS].

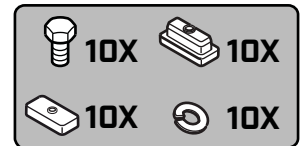

MAKE SURE ROOF PANELS ARE LEVEL

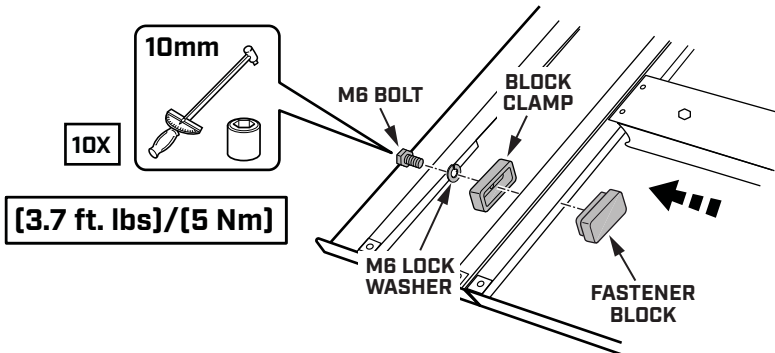
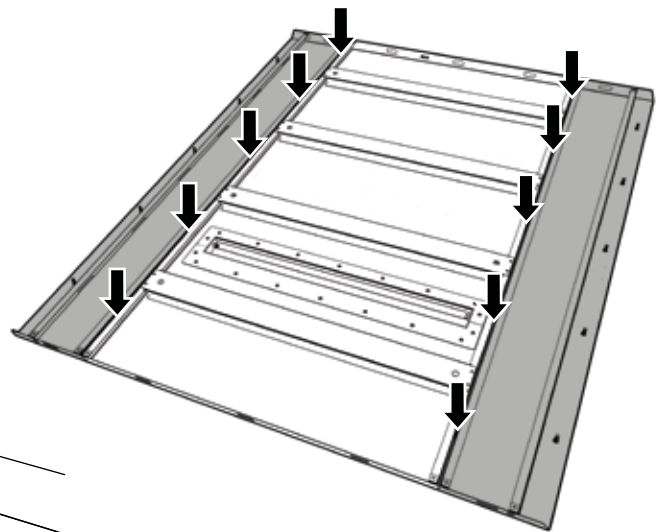

I-SHEET-NA-C3

STEP 5

USE A 10MM COMBINATION WRENCH TO REMOVE THE LOCK NUTS AND FENDER WASHERS FROM THE ROOF BOLTS AND SAVE FOR REUSE.



AIR VENT INDICATES REAR

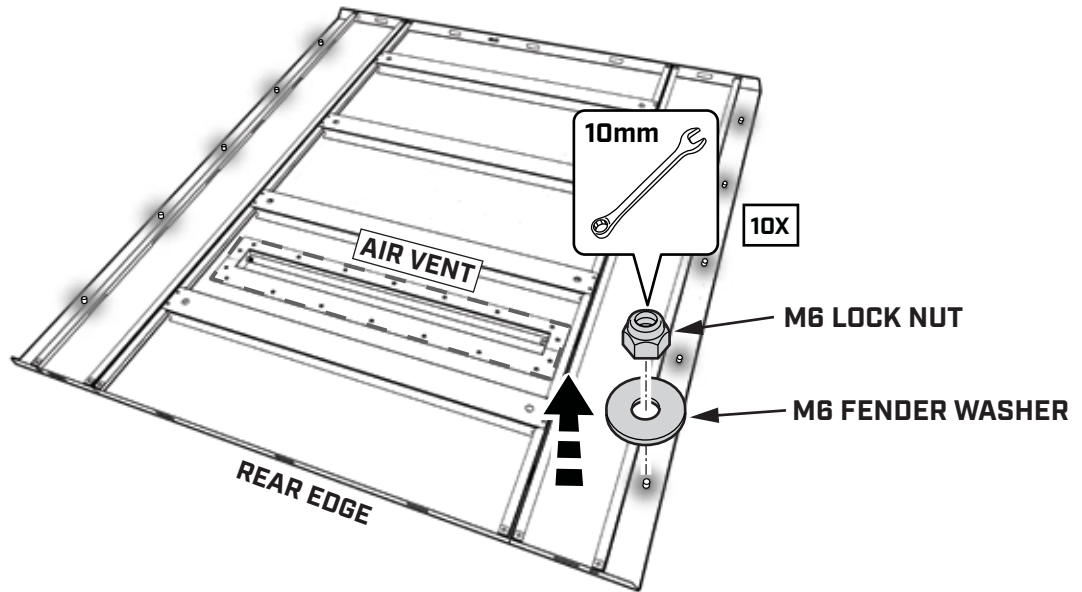

STEP 6

RETRIEVE THE FASTENER BLOCKS FROM THE FITMENT KIT AND PLACE 15 ON EACH SIDE OF THE ROOF PANEL.

TAKE APART THE FASTENER BLOCKS SO THEY ARE READY TO USE DURING ASSEMBLY.

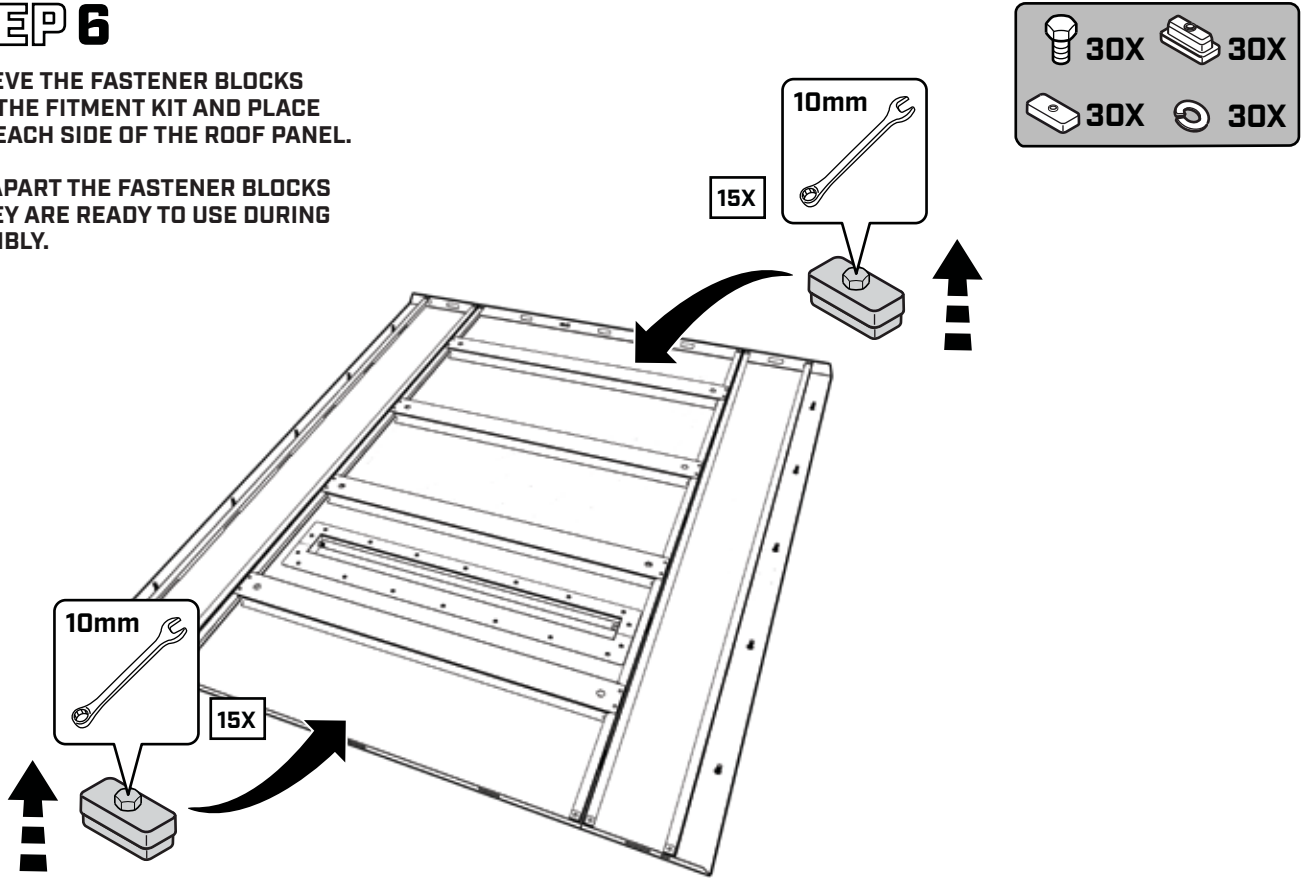

STEP 7

LOCATE THE RIGHT PANEL IN THE SMARTCAP PACKAGE AND BRING IT TO YOUR WORK AREA.



SLANTED EDGE INDICATES REAR

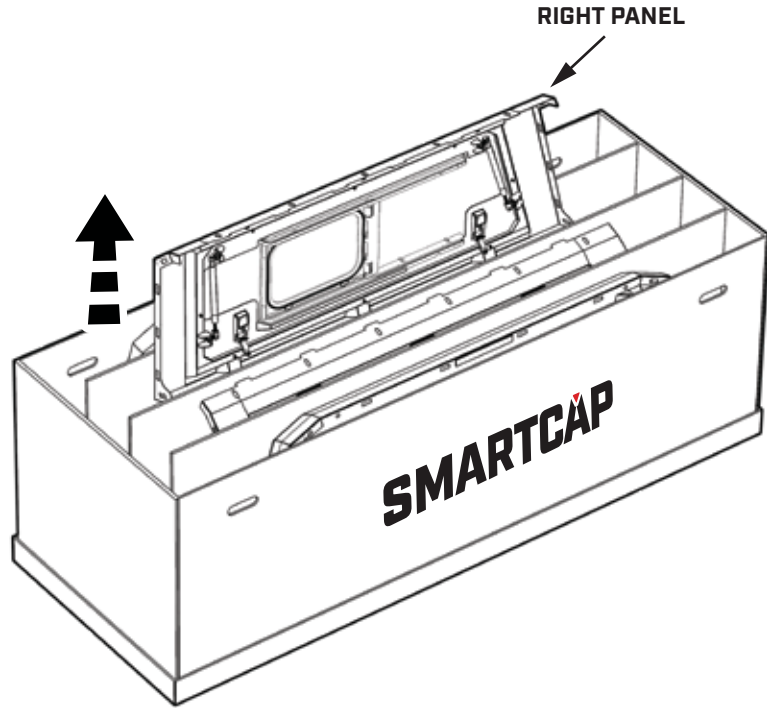

STEP 8

INSERT PANEL TABS INTO THE NARROW SLOTS JUST ABOVE FOAM PADDING ON ROOF PANEL.

TAP FIRMLY WITH PALM OF HAND UNTIL THERE IS A 2-3MM GAP.

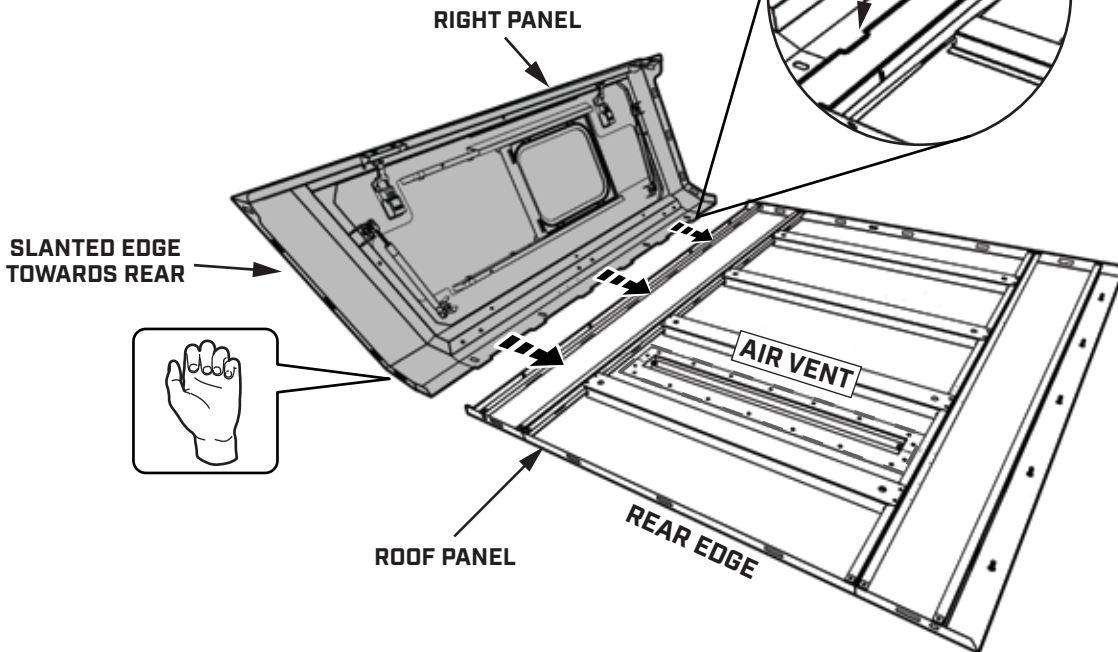
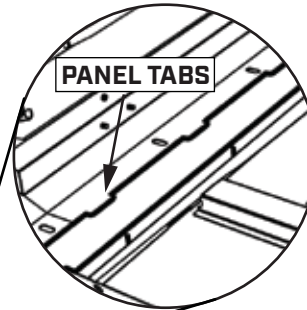

I-SHEET-NA-C3

STEP 9

HAND TIGHTEN M6 LOCK NUT WITH M6 FENDER WASHER TO ALL BOLTS.



SUPPORT RIGHT PANEL UNTIL ASSEMBLED TO FRONT FLANGE

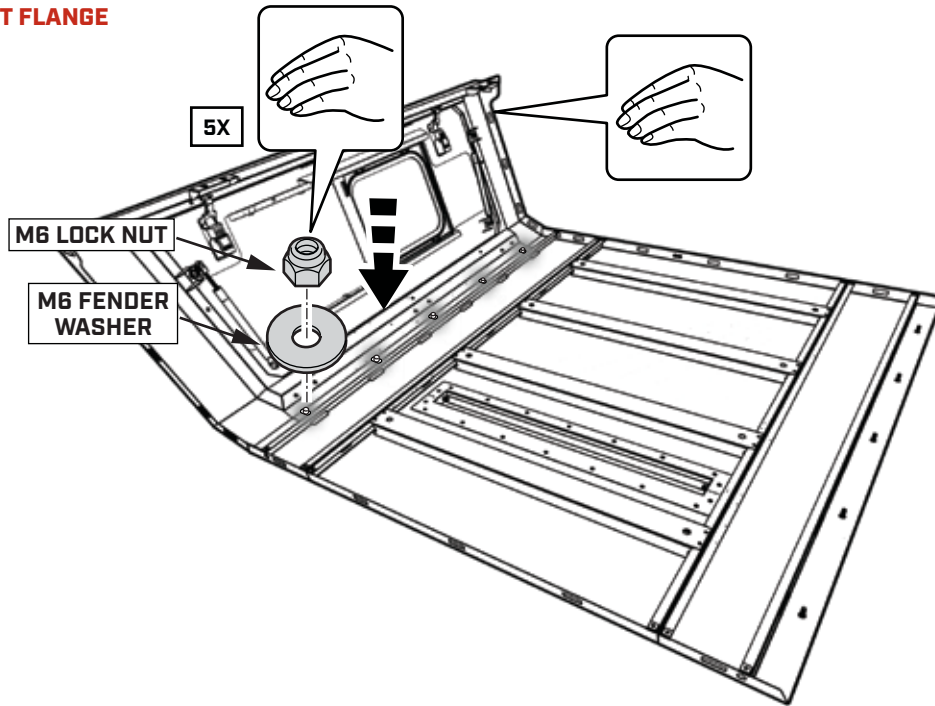

STEP 10

LOCATE THE FRONT FLANGE IN THE SMARTCAP PACKAGE AND BRING IT TO YOUR WORK AREA.

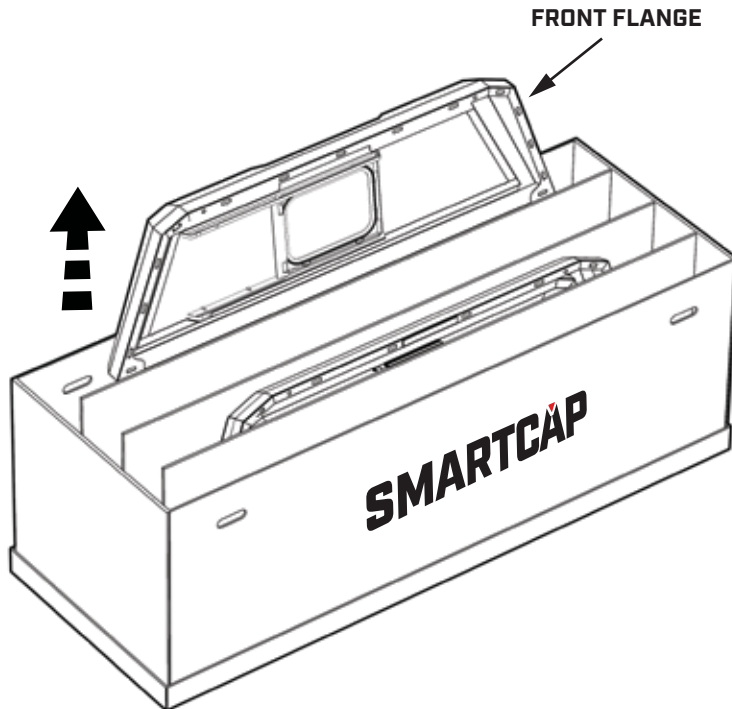

STEP 11

PLACE FRONT FLANGE AS SHOWN BELOW.

HAND TIGHTEN TWO FASTENER BLOCKS AT THE INDICATED LOCATIONS TO SUPPORT THE RIGHT PANEL AND FRONT FLANGE.

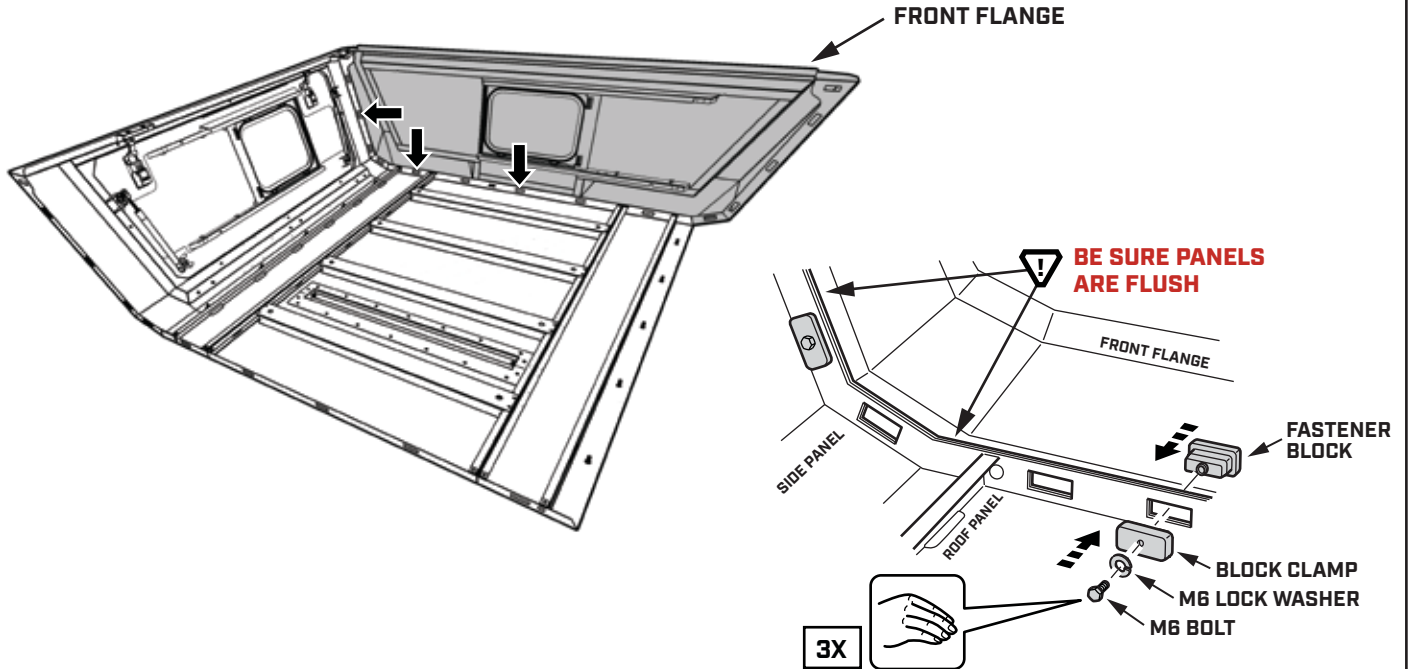

STEP 12

LOCATE THE LEFT PANEL IN THE SMARTCAP PACKAGE AND BRING IT TO YOUR WORK AREA.



 **SLANTED EDGE INDICATES REAR**

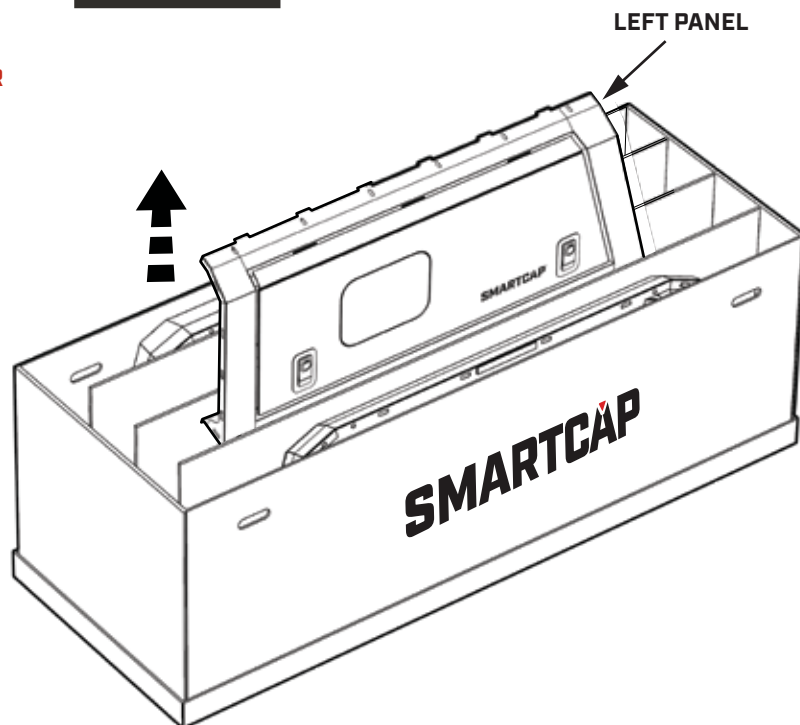

STEP 13

INSERT PANEL TABS INTO THE NARROW SLOTS JUST ABOVE FOAM PADDING ON ROOF PANEL.

TAP FIRMLY WITH PALM OF HAND UNTIL THERE IS A 2-3MM GAP.

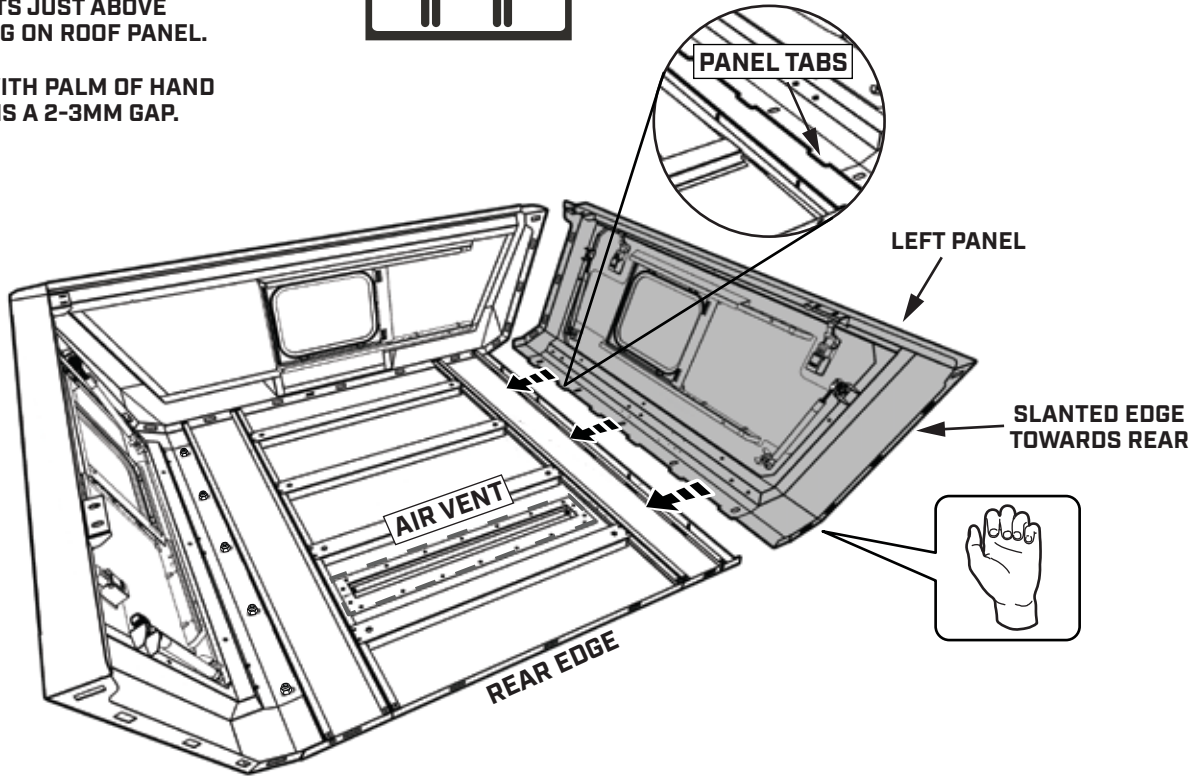

STEP 14

HAND TIGHTEN M6 LOCK NUT WITH M6 FENDER WASHER TO ALL BOLTS.

! SUPPORT LEFT PANEL UNTIL ASSEMBLED TO FRONT FLANGE

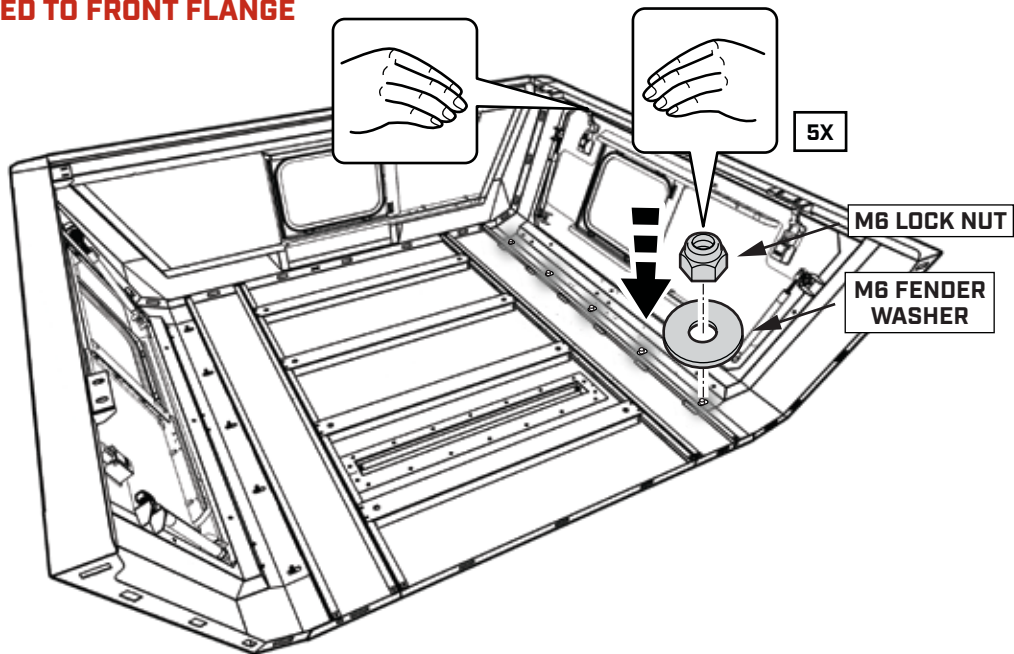

STEP 15

INSTALL HARDWARE ALONG FRONT FLANGE WITH BOLT ON INSIDE.

START AT CENTER OF THE FRONT FLANGE AND WORK YOUR WAY OUTWARDS.

ADJUST LEFT AND RIGHT PANELS TO ALIGN THE FASTENER BLOCK HOLES.

HAND TIGHTEN ONLY.

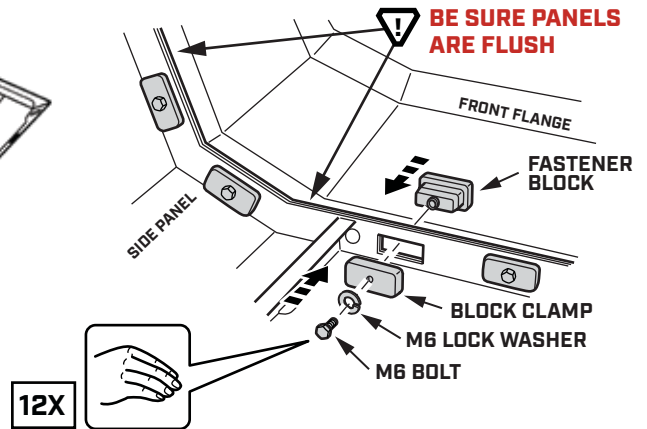
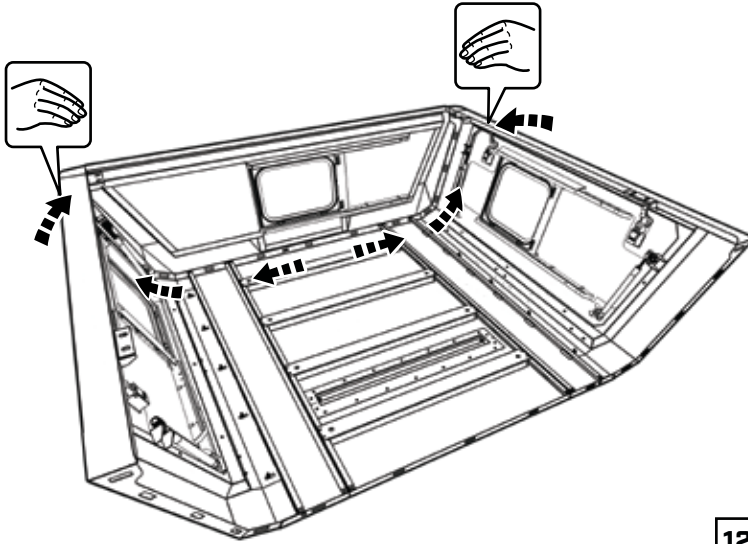

STEP 16

LOCATE THE REAR FLANGE IN THE SMARTCAP PACKAGE AND BRING IT TO YOUR WORK AREA.

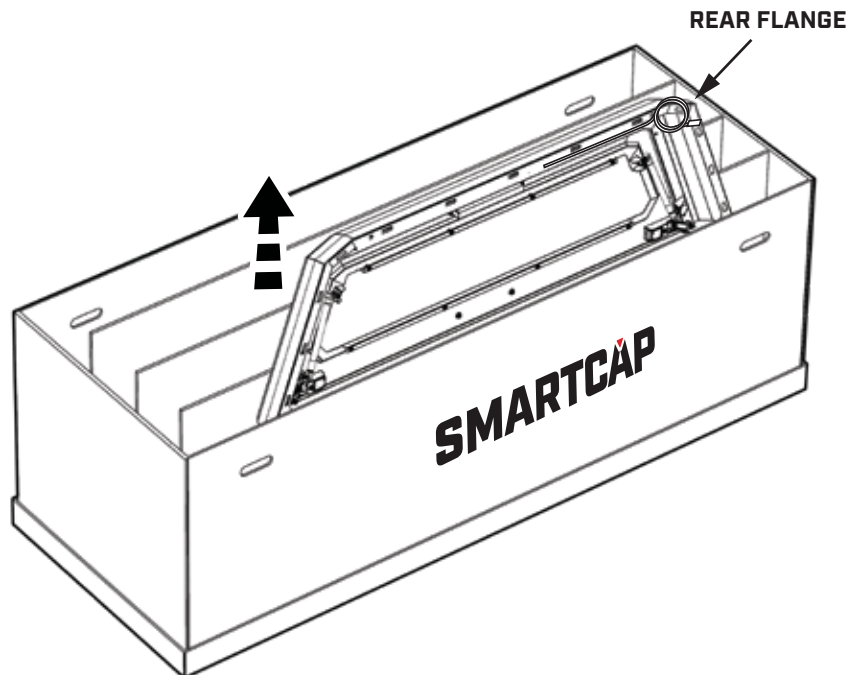

STEP 17

PLACE REAR FLANGE AS SHOWN BELOW.

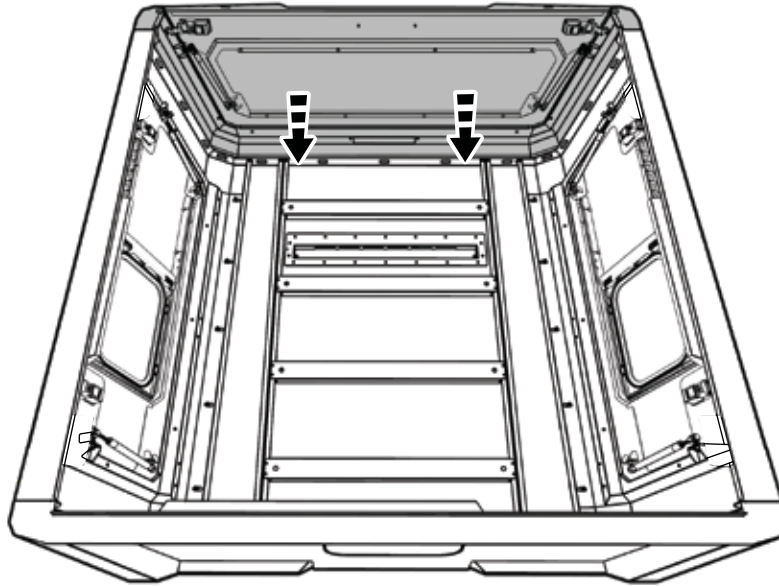

STEP 18

INSTALL HARDWARE ALONG REAR FLANGE WITH BOLT ON INSIDE.



START AT CENTER OF THE REAR FLANGE AND WORK YOUR WAY OUTWARDS.

ADJUST LEFT AND RIGHT PANELS TO ALIGN THE FASTENER BLOCK HOLES.

HAND TIGHTEN ONLY.

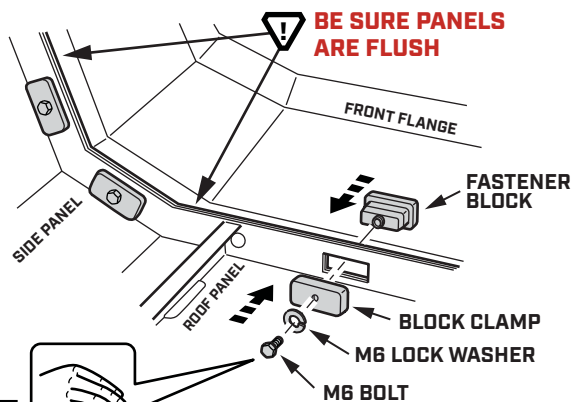

15X

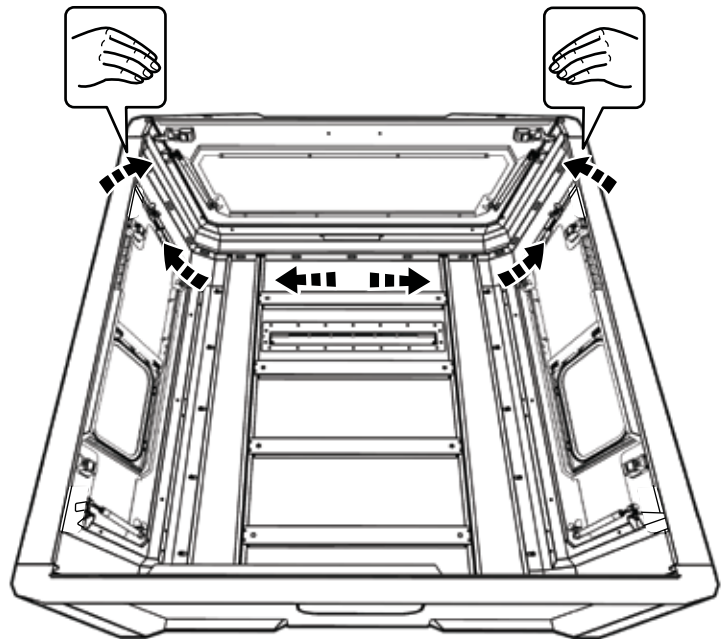

I-SHEET-NA-C3

STEP 19

TIGHTEN ALL HARDWARE WITH TORQUE WRENCH AND 10MM SOCKET TO 3.7 FT. LBS. (5 NEWTON METERS)

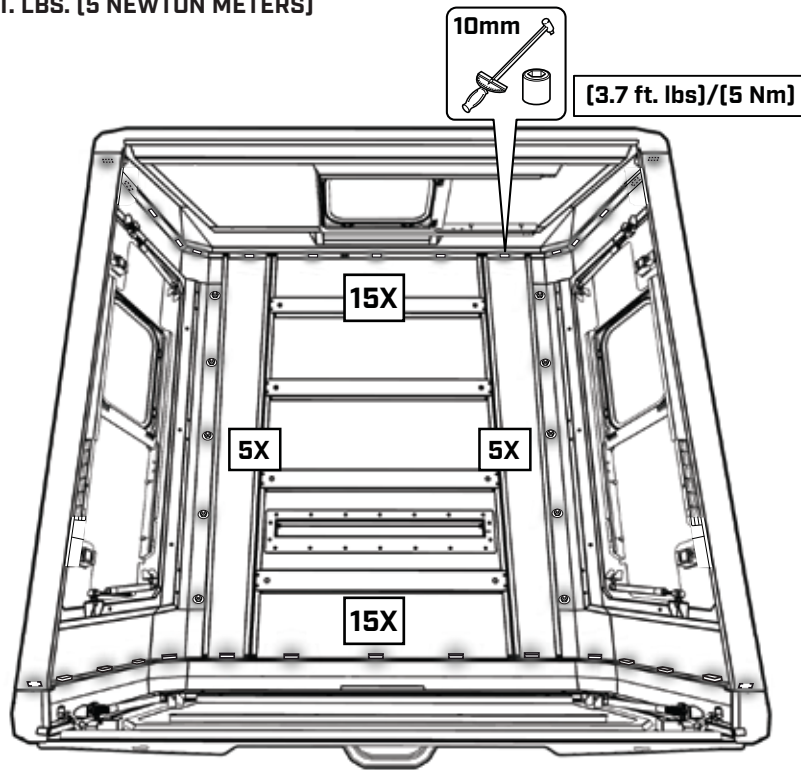

STEP 20

ENSURE THE ENTIRE BOTTOM EDGE OF THE SMARTCAP IS CLEAN.

LOCATE BOTH RETENTION TABS ON THE REAR FLANGE AND BEND EACH TO A 45-DEGREE ANGLE FOR D-RUBBER FITMENT.

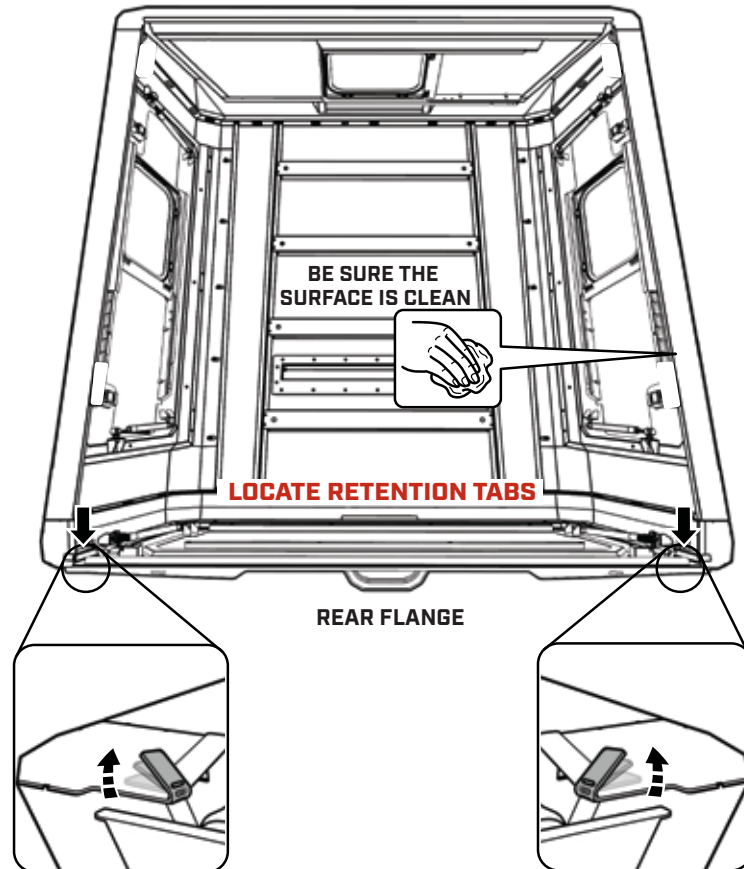

STEP 21



TRIM THE D-RUBBER WITH A CLEAN, STRAIGHT CUT.

APPLY 2-3 INCHES OF GEL SUPER GLUE NEAR THE RETENTION TABS, ALONG THE BOTTOM EDGE OF THE REAR FLANGE

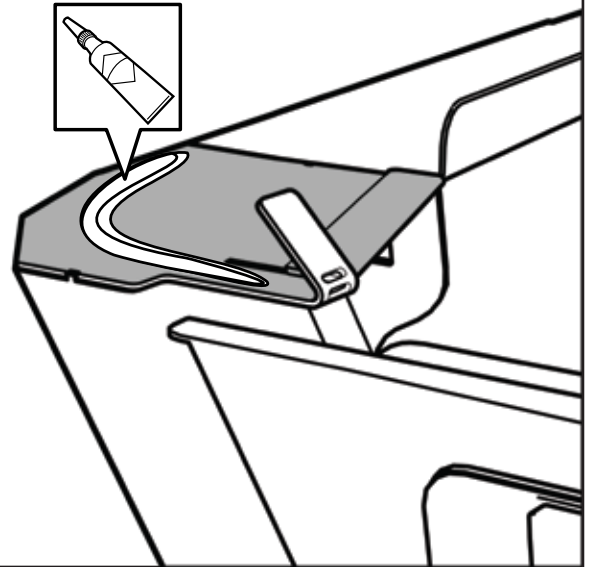
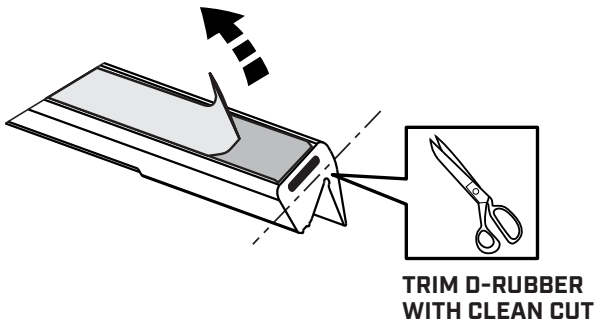

STEP 22

FULLY INSERT THE RETENTION TAB INTO THE SLOT ON THE D-RUBBER. ENSURE THE D-RUBBER IS ORIENTED CORRECTLY WITH ITS PROFILE MATCHING THE CONTOUR OF THE REAR FLANGE.

PRESS DOWN FIRMLY ON THE TAB AND THE D-RUBBER TO BOND IT TO THE REAR FLANGE, CREATING A TIGHT SEAL.

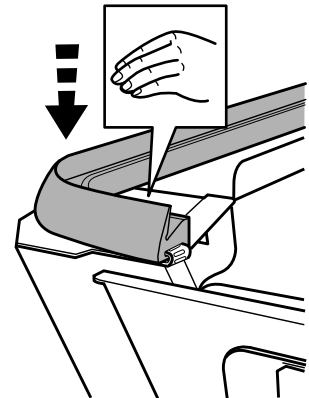
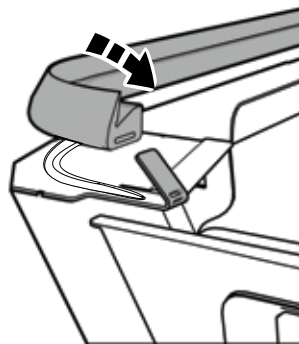

CORRECT D-RUBBER ORIENTATION

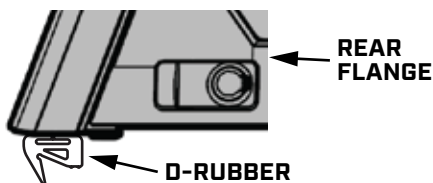

INCORRECT D-RUBBER ORIENTATION

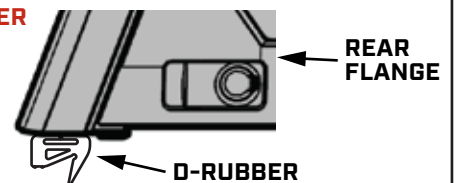

STEP 23

ALIGN THE D-RUBBER ALONG THE SMARTCAP'S EDGE, MAINTAINING A CONSISTENT 1/8 INCH GAP FROM THE EDGE.

START FROM ONE CORNER AND WORK YOUR WAY AROUND THE CAP TO ENSURE PROPER PLACEMENT AND ALIGNMENT.

APPLY 2-3 INCHES OF GEL SUPER GLUE AT THE FRONT CORNERS OF THE SMARTCAP, ALONG THE BOTTOM EDGE OF THE FRONT FLANGE.

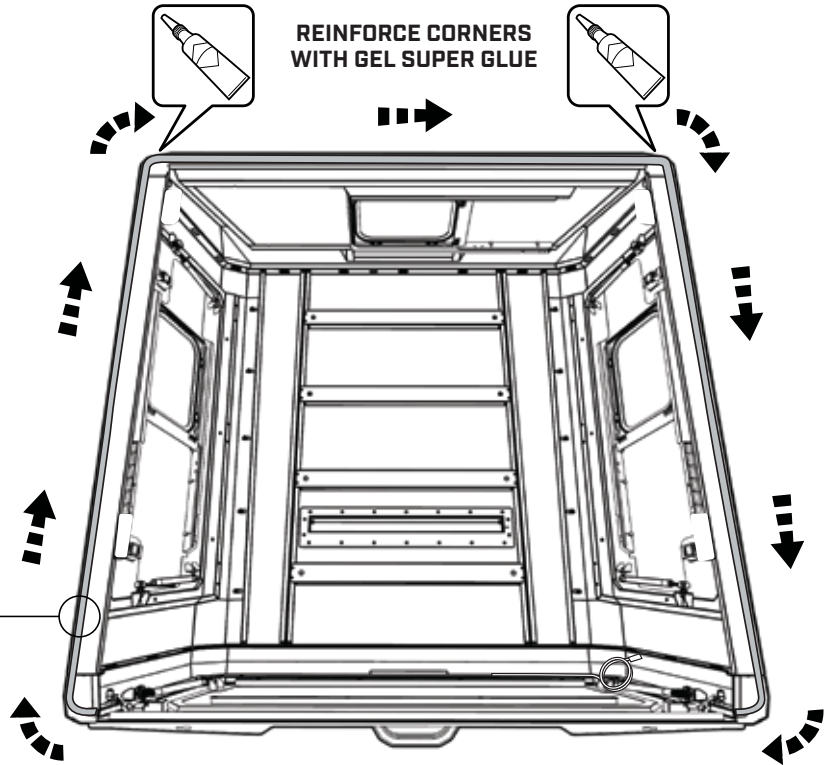
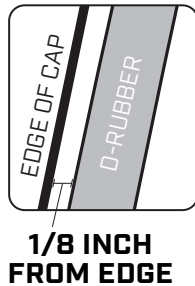

STEP 24

TRIM ANY EXCESS D-RUBBER BEYOND THE EDGE FOR A NEAT FINISH.

APPLY 2-3 INCHES OF GEL SUPER GLUE NEAR THE RETENTION TAB, ALONG THE BOTTOM EDGE OF THE REAR FLANGE. FULLY INSERT THE RETENTION TAB INTO THE SLOT ON THE D-RUBBER.

PRESS DOWN FIRMLY ON THE TAB AND THE D-RUBBER TO BOND IT TO THE REAR FLANGE, CREATING A TIGHT SEAL.

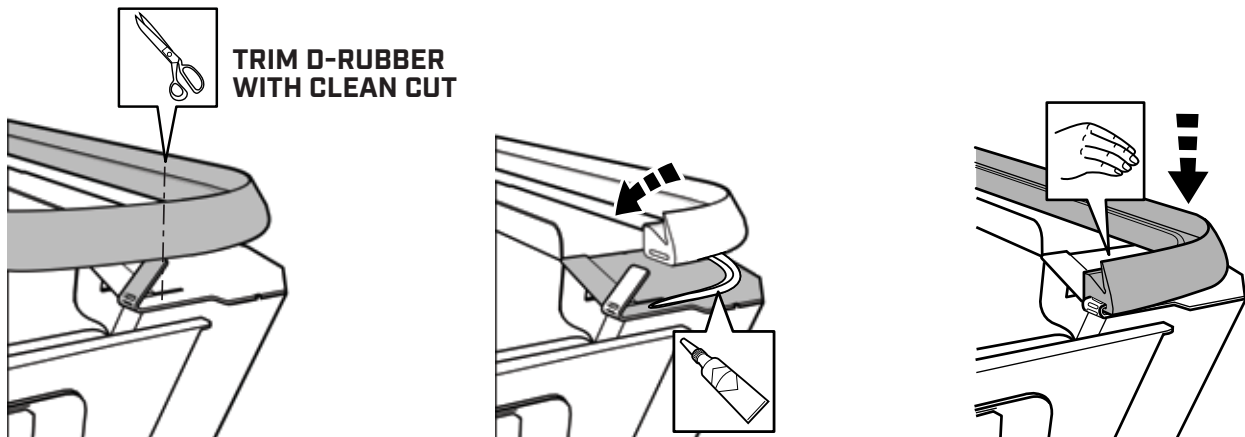

I-SHEET-NA-C3

INSTALLATION HARDWARE

MOUNTING BRACKETS

REAR
BRACKETS
[SHORT]
LEFT AND RIGHT

2X

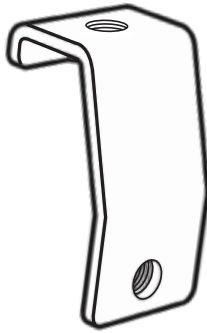

FRONT
BRACKETS
[LONG]
LEFT AND RIGHT

2X



THICK RUBBER PAD

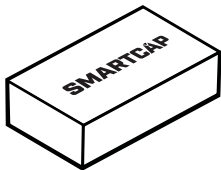

8X

5mm FOAM SEAL TAPE

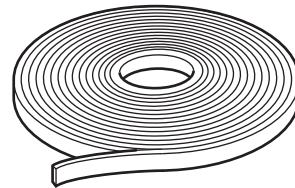

1X

M10 BUTTON BOLT



8X

M10 LOCK WASHER



8X

M10 FENDER WASHER



8X



IMPORTANT

- ▼ ASSISTANCE WILL BE NEEDED FOR THIS INSTALLATION. FOUR PEOPLE ARE RECOMMENDED TO LIFT THE SMARTCAP ONTO THE VEHICLE.
- ▼ AVOID PINCHING OR CRUSHING HANDS AND FINGERS.
- ▼ READ THROUGH THE ENTIRE PROCEDURE BEFORE STARTING.

STEP 25

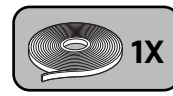

INSPECT THE TRUCK BED. IF FRONT EDGE IS LOWER THAN THE SIDES, ADD FOAM SEAL TAPE TO THE FRONT EDGE OF THE BED.

NOTE: IF SLOPE IS PRESENT, USE THE EXCESS FOAM SEAL TAPE AND APPLY TO EACH SIDE TO LEVEL OUT THE FRONT EDGE

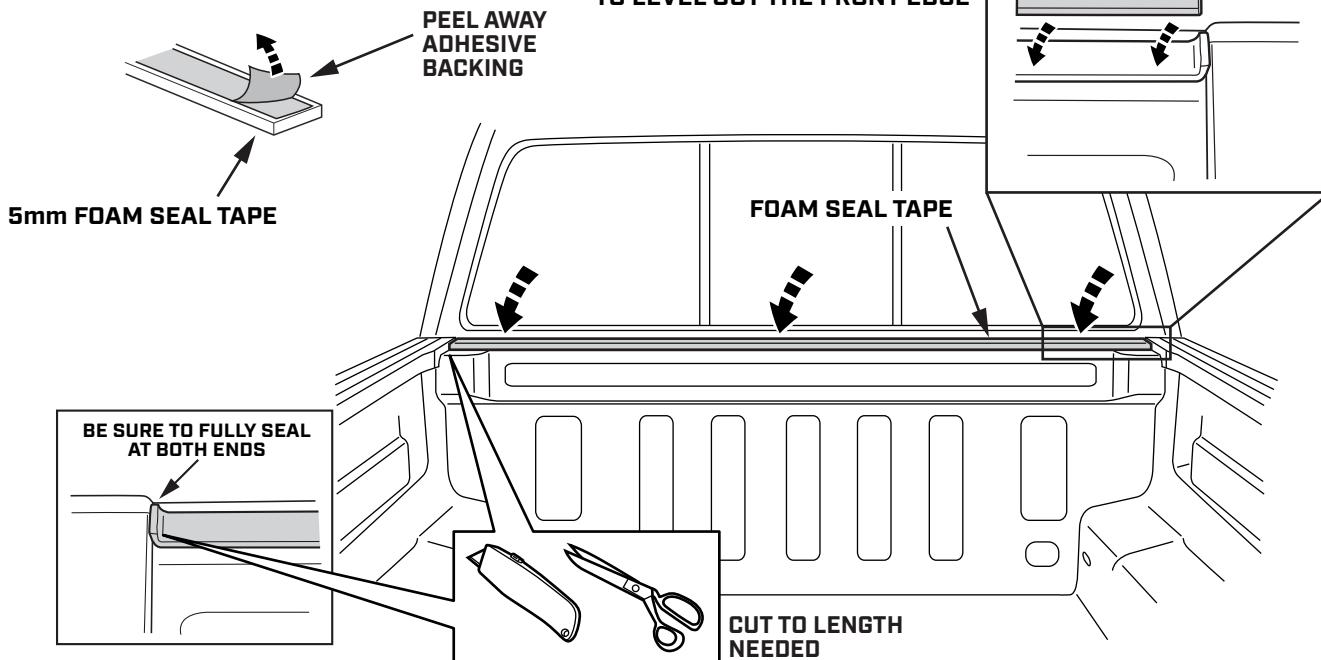

STEP 26

USE A UTILITY KNIFE TO CUT AWAY THE STAKE POCKET IMPRESSIONS LOCATED ON THE FRONT LEFT AND RIGHT CORNERS OF THE TRUCK BED.

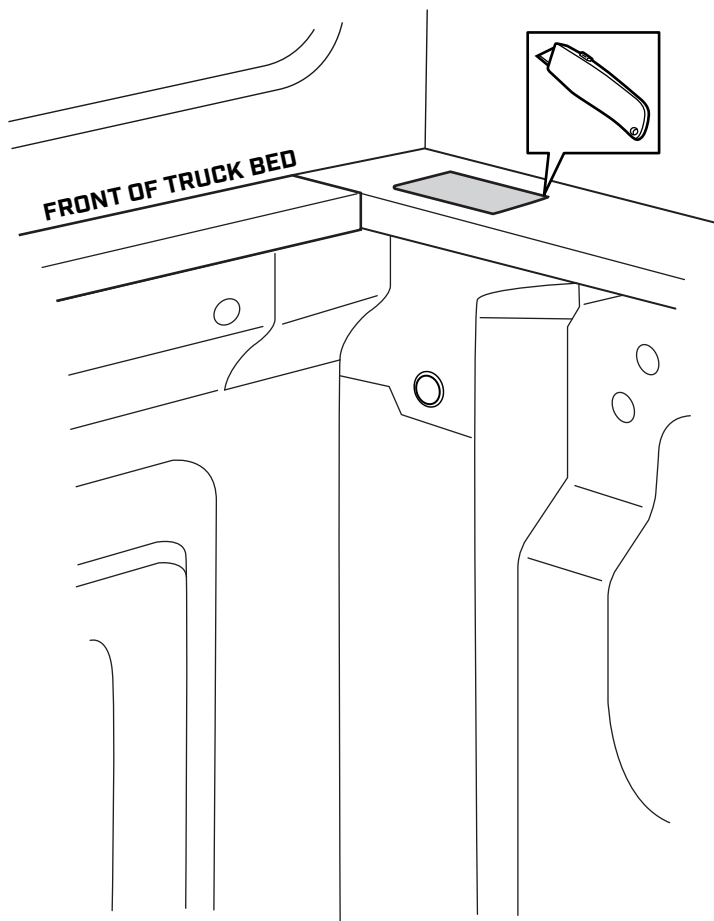

STEP 27

REMOVE THE BLACK PLUG FROM THE SIDE WALL LOCATED UNDER THE TRUCK BED RAILING.

INSERT THE LEFT AND RIGHT FRONT MOUNTING BRACKETS INTO THE OPENINGS ON THE TRUCK BED RAILS.

USING A 6MM HEX SOCKET, TIGHTEN MOUNTING BRACKETS TO THE TRUCK BED WITH M10 BUTTON HEAD BOLT, M10 LOCK WASHER, AND M10 FENDER WASHER AS SHOWN.

BE SURE MOUNTING BRACKET IS FLUSH WITH TRUCK BED RAIL

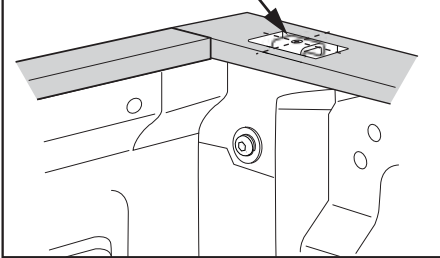

FRONT MOUNTING BRACKET (LONG)

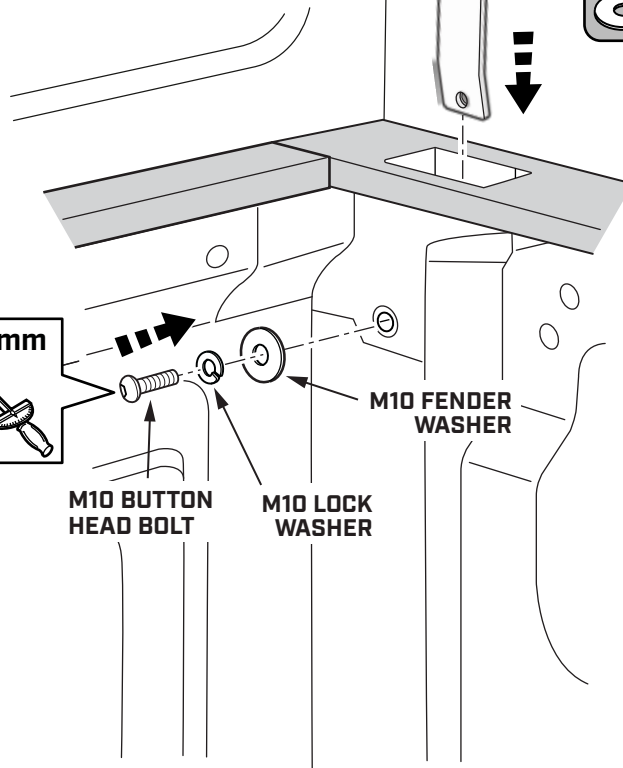
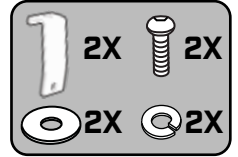

2X

[8.8 ft. lbs]/[12 Nm]



6mm

M10 BUTTON HEAD BOLT

M10 LOCK WASHER

M10 FENDER WASHER

STEP 28

REMOVE THE BLACK PLUG FROM THE SIDE WALL LOCATED UNDER THE TRUCK BED RAILING.

INSERT THE LEFT AND RIGHT REAR MOUNTING BRACKETS INTO THE OPENINGS ON THE TRUCK BED RAILS.

USING A 6MM HEX SOCKET, TIGHTEN MOUNTING BRACKETS TO THE TRUCK BED WITH M10 BUTTON HEAD BOLT, M10 LOCK WASHER, AND M10 FENDER WASHER AS SHOWN.

BE SURE MOUNTING BRACKET IS FLUSH WITH TRUCK BED RAIL

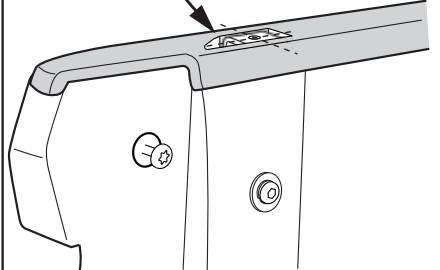

REAR MOUNTING BRACKET (SHORT)

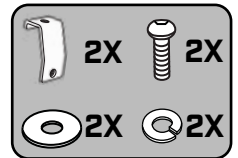

[8.8 ft. lbs]/[12 Nm]

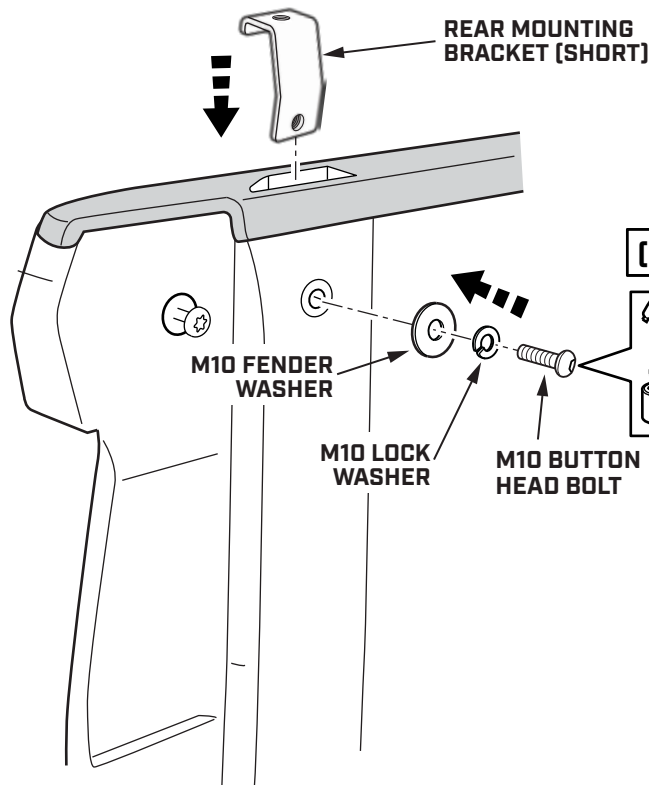

6mm

M10 FENDER WASHER

M10 LOCK WASHER

M10 BUTTON HEAD BOLT

2X

STEP 29

REMOVE THE ADHESIVE BACKING FROM THE THICK RUBBER PAD.

PLACE TWO THICK RUBBER PADS ON EACH SIDE OF ALL FOUR MOUNTING HOLES ALONG THE BOTTOM EDGE OF THE SMARTCAP.

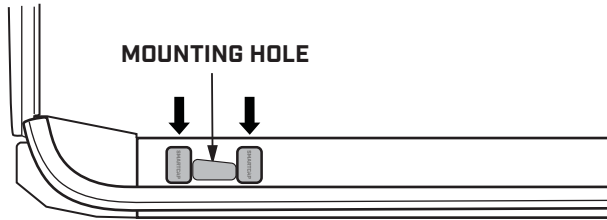

THICK RUBBER PAD

8X

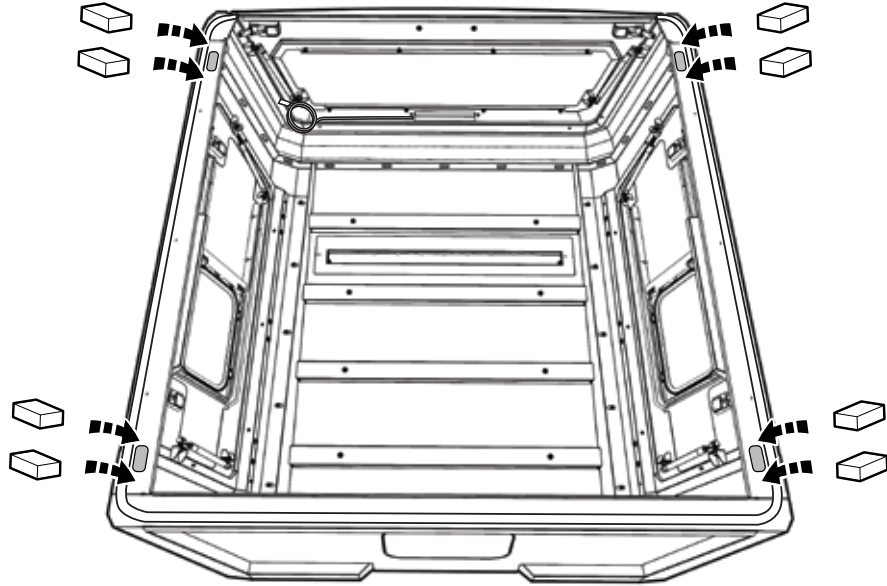
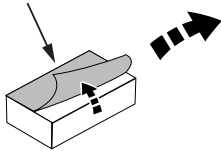

STEP 30

USE 4 PEOPLE TO LIFT THE ASSEMBLED SMARTCAP ONTO THE TRUCK BED.

TO AVOID DAMAGE TO THE D-RUBBER, DO NOT SLIDE THE SMARTCAP INTO PLACE.

4 PERSON JOB

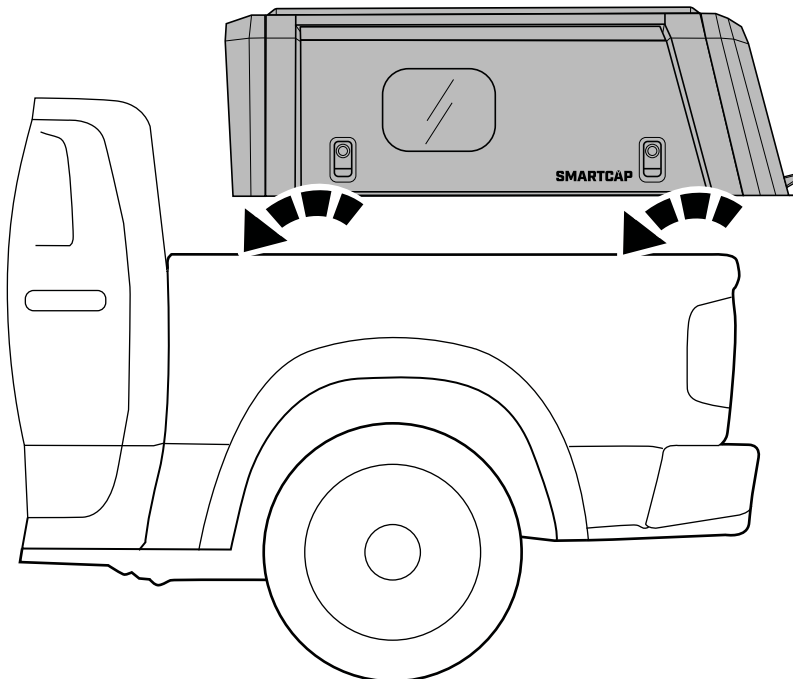

I-SHEET-NA-C3

STEP 31

CHECK THAT THE SMARTCAP IS PROPERLY POSITIONED AND CENTERED ON THE TRUCK BED.

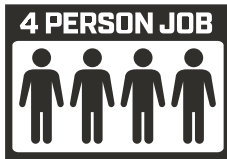

IT'S IMPORTANT THAT THE SMARTCAP IS NOT PUSHED TOO FAR FORWARD, LEAVING A GAP BETWEEN THE SMARTCAP AND THE CAB.

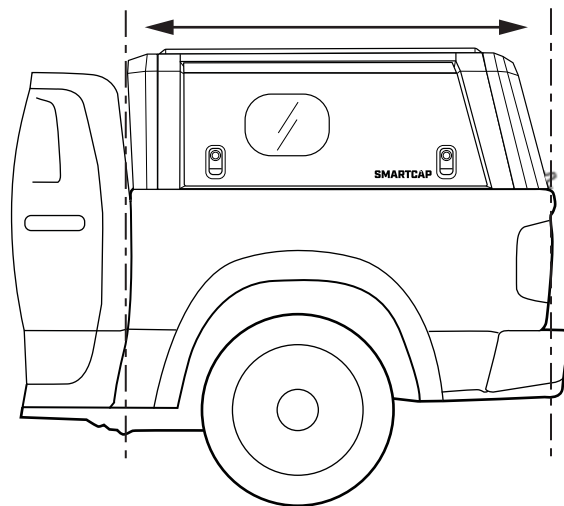
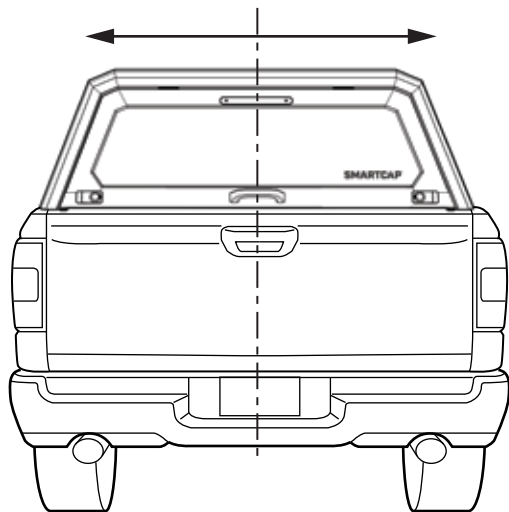

STEP 32

WALK AROUND THE TRUCK BED TO MAKE SURE THE D-RUBBER FITMENT IS CORRECT AND THAT THE RUBBER LIP IS PROPERLY TUCKED UNDERNEATH THE CAP.

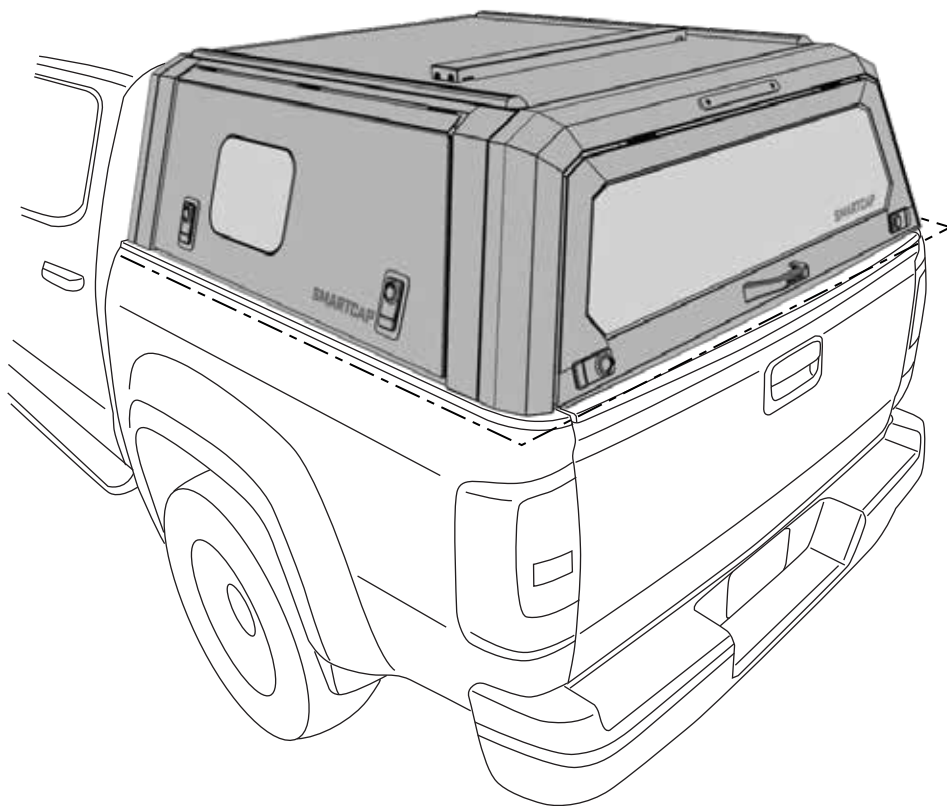

**YOU MAY NOTICE THAT THE SEAL ON THE SLIDING PORTAL WINDOW MIGHT APPEAR WRINKLED. THIS IS DUE TO THE ANTI-SLIP COATING AND IS NOT A CAUSE FOR CONCERN.*

I-SHEET-NA-C3

STEP 33

SECURE THE SMARTCAP TO ALL FOUR MOUNTING BRACKETS ON ALL FOUR CORNERS USING M10 BUTTON HEAD BOLT, M10 LOCK WASHERS AND M10 FENDER WASHER AS SHOWN, HAND TIGHTEN ONLY.

M10 BUTTON HEAD BOLT
M10 LOCK WASHER
M10 FENDER WASHER

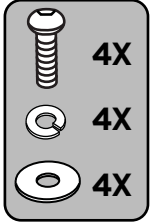
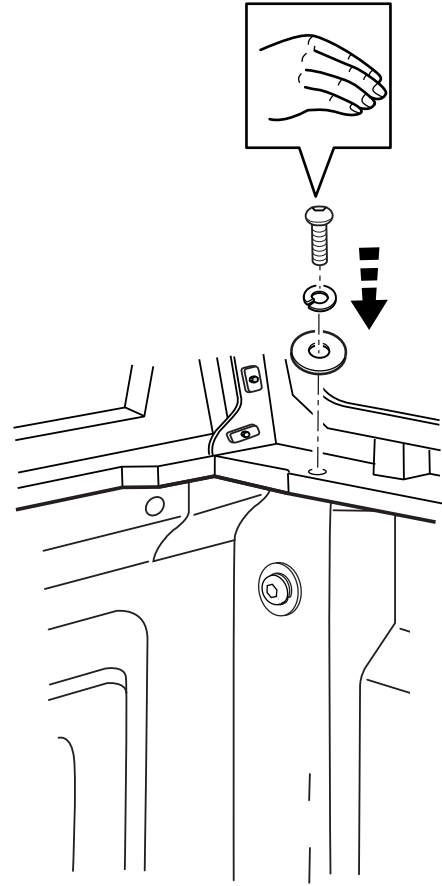
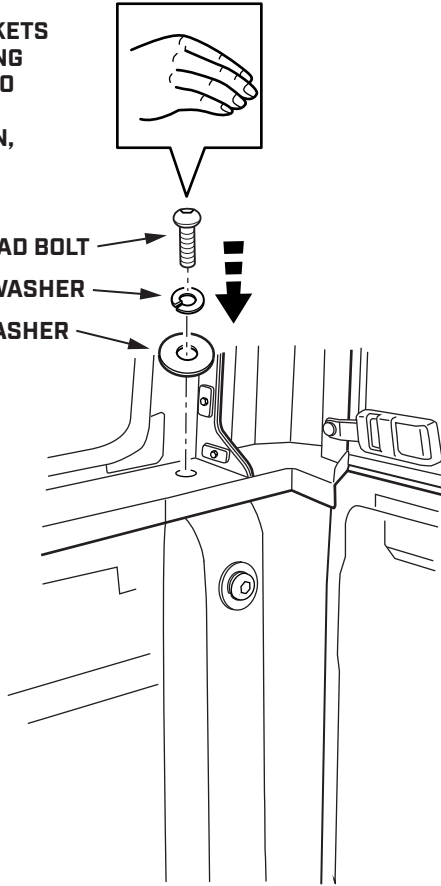

STEP 34

TIGHTEN ALL FOUR M10 BOLTS USING A 6MM HEX SOCKET.

[8.8 ft. lbs]/[12 Nm]

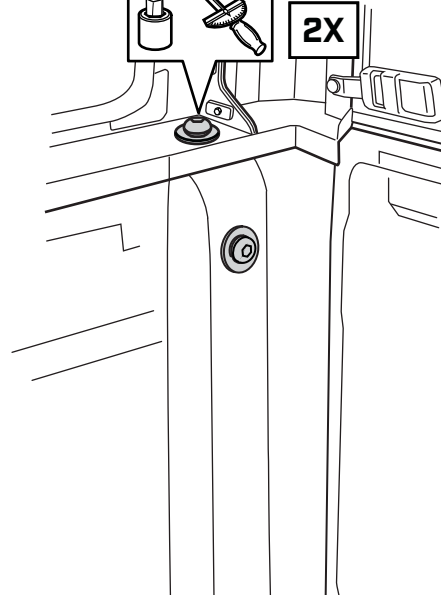
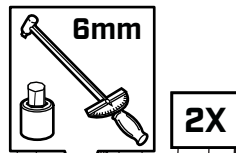

[8.8 ft. lbs]/[12 Nm]

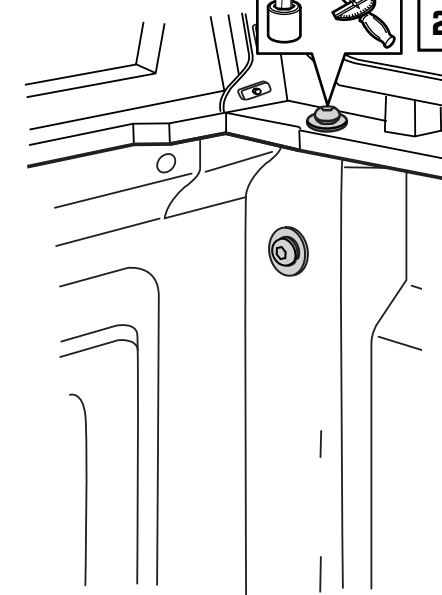
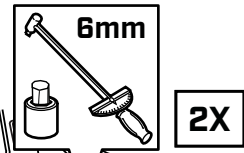

STEP 35

ONCE YOU HAVE FULLY TIGHTENED ALL FASTENERS, YOU WILL NEED TO CONFIRM CORRECT FITMENT OF THE CAP BY CHECKING THE RUBBER SEAL LOCATED ON THE REAR DOOR AS WELL AS THE D-RUBBER.

THE RUBBER SEAL SHOULD MAKE CONTACT WITH THE TAILGATE WITH ZERO GAP BETWEEN THE TWO.

THE D-RUBBER SHOULD MAKE CONTACT WITH THE TAILGATE WITHOUT IMPOSING ON THE OPERATION OF THE TAILGATE.

 THE REAR DOOR RUBBER SEAL SHOULD MAKE CONTACT ALONG THE ENTIRE LENGTH OF THE TAILGATE

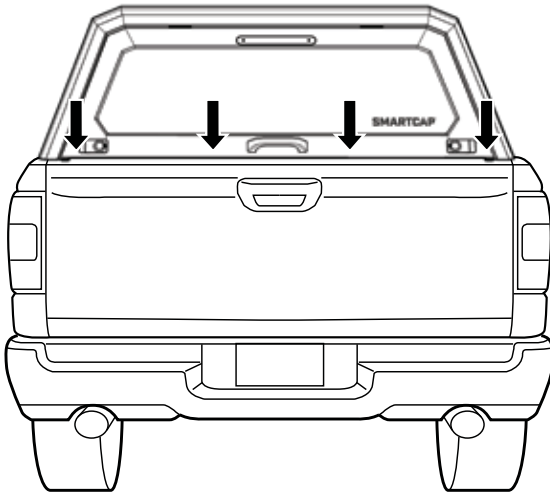

 THERE SHOULD BE 2MM-3MM OF SPACE BETWEEN THE D-RUBBER BASE AND THE D-RUBBER LIP

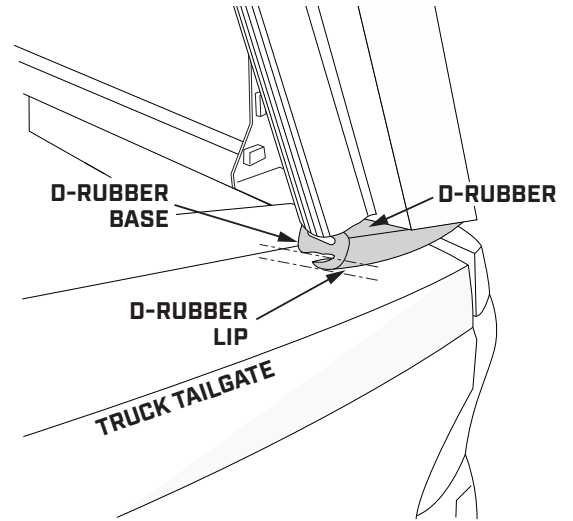

STEP 36

TO ADJUST THE FITMENT OF THE CAP, SLIGHTLY LOOSENING THE M10 BOLTS FOR THE REAR MOUNTING BRACKETS.

IF THERE IS A GAP BETWEEN THE RUBBER SEAL AND THE TAILGATE, GRAB THE CAP NEAR THE ROOF AND FIRMLY PRESS DOWN ON THE SMARTCAP. WHILE PRESSING DOWNWARDS, TIGHTEN THE M10 BOLTS TO THE REQUIRED TORQUE SPEC OF [8.8 ft. lbs]/[12 Nm].

IF THE TAILGATE IS DIFFICULT TO OPEN, GRAB THE CAP NEAR THE ROOF AND FIRMLY PUSH THE CAP UPWARDS. WHILE PUSHING UPWARDS, TIGHTEN THE M10 BOLTS TO THE REQUIRED TORQUE SPEC OF [8.8 ft. lbs]/[12 Nm].

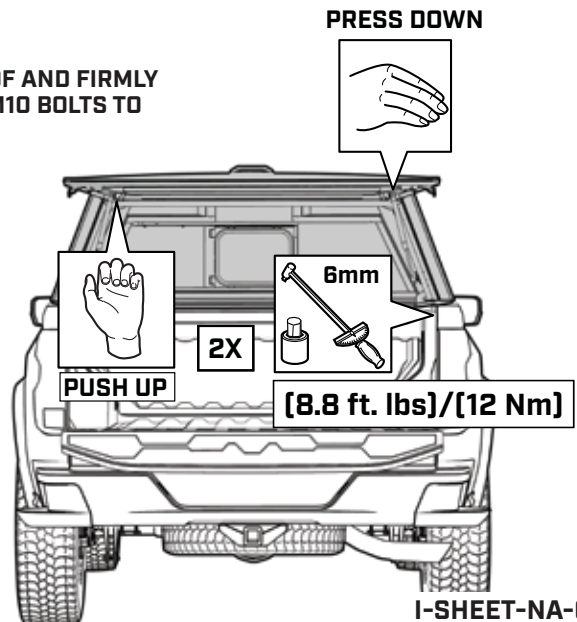
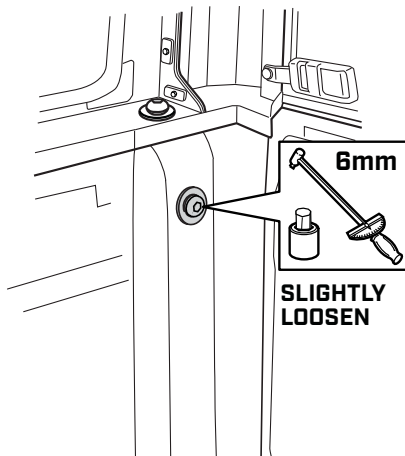

I-SHEET-NA-C3

THIRD BRAKE LIGHT HARDWARE



IMPORTANT

- ▼ BE SURE THE VEHICLE IS TURNED OFF FOR THIS INSTALLATION.
- ▼ READ THROUGH THE ENTIRE PROCEDURE BEFORE STARTING AND FOLLOW THE STEPS CAREFULLY TO ENSURE THE THIRD BRAKE LIGHT WILL FUNCTION PROPERLY.
- ▼ USE A TEST LIGHT TO CHECK FOR SUCCESSFUL INSTALLATION.

STEP 37-42

GM COLORADO (2023)

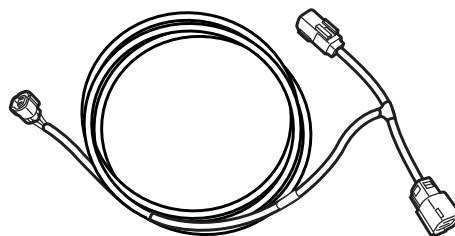

1X

STEP 43-54

GM CANYON (2023)

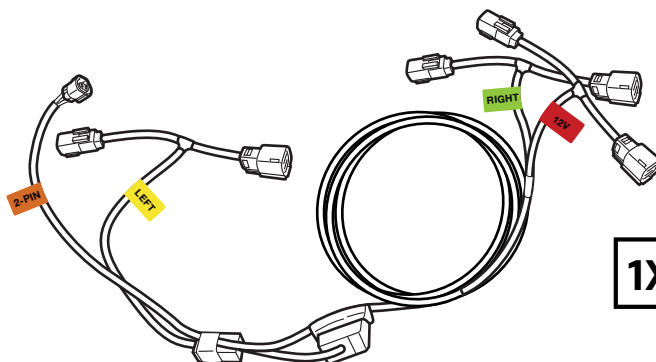

1X

STEP 37

UNTIE THE THIRD BRAKE LIGHT EXTENSION HARNESS FROM WHERE IT IS ATTACHED TO THE SMARTCAP AT THE LEFT REAR CORNER.

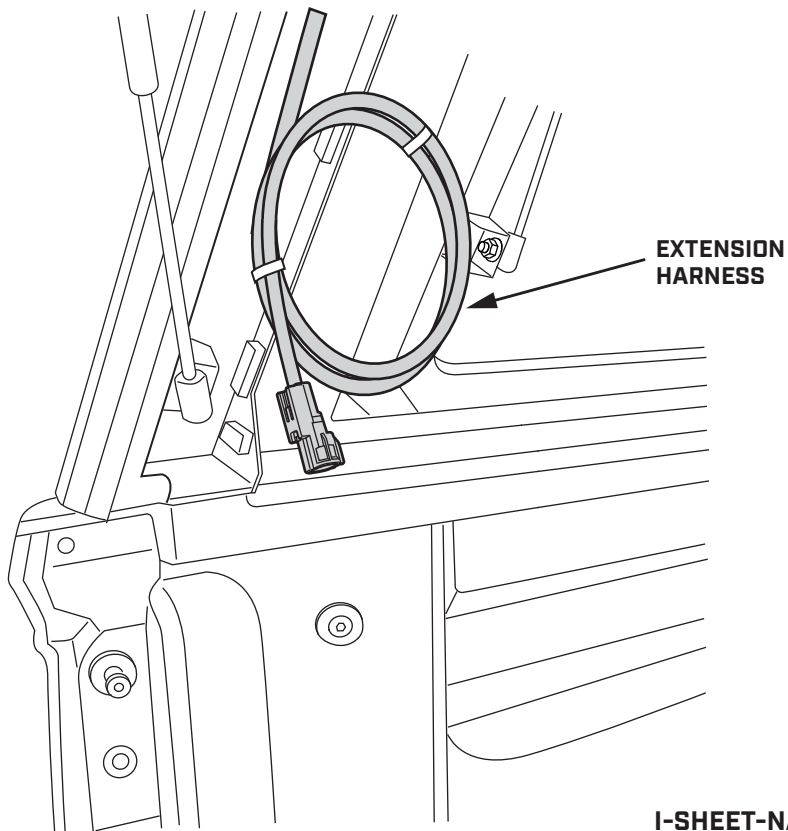

I-SHEET-NA-C3

STEP 38

ROUTE THE THIRD BRAKE LIGHT EXTENSION HARNESS IN THROUGH THE BED RAIL OPENING AND DOWN TOWARDS THE REAR BUMPER.

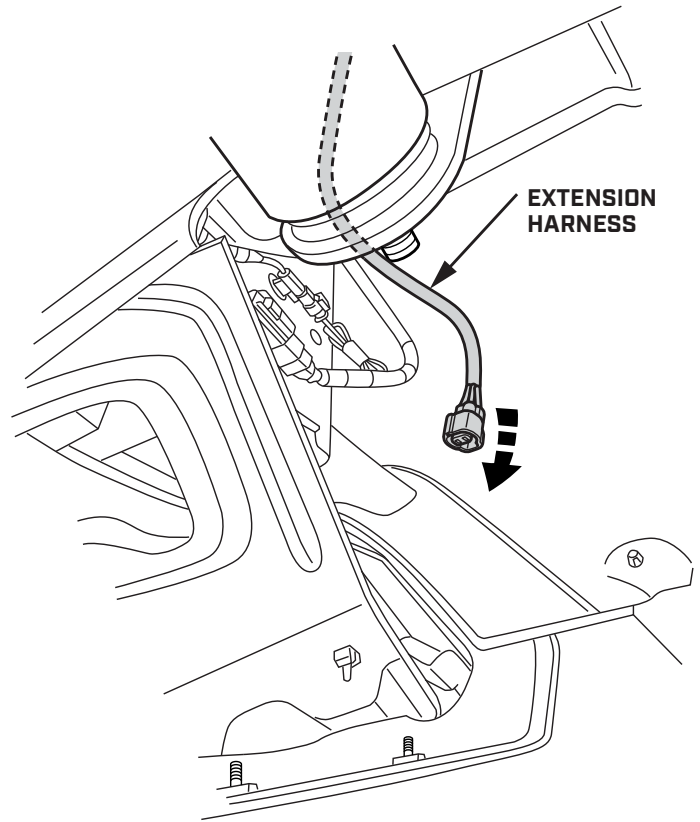
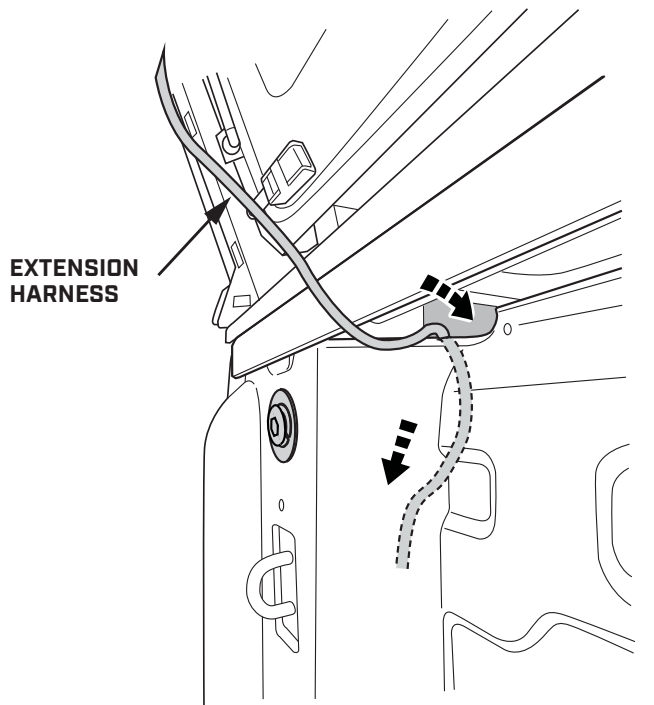

STEP 39

FROM BELOW, PLUG THE CONNECTOR FROM THE EXTENSION HARNESS INTO THE 2-PIN CONNECTOR OF THE T-HARNESS AS SHOWN.

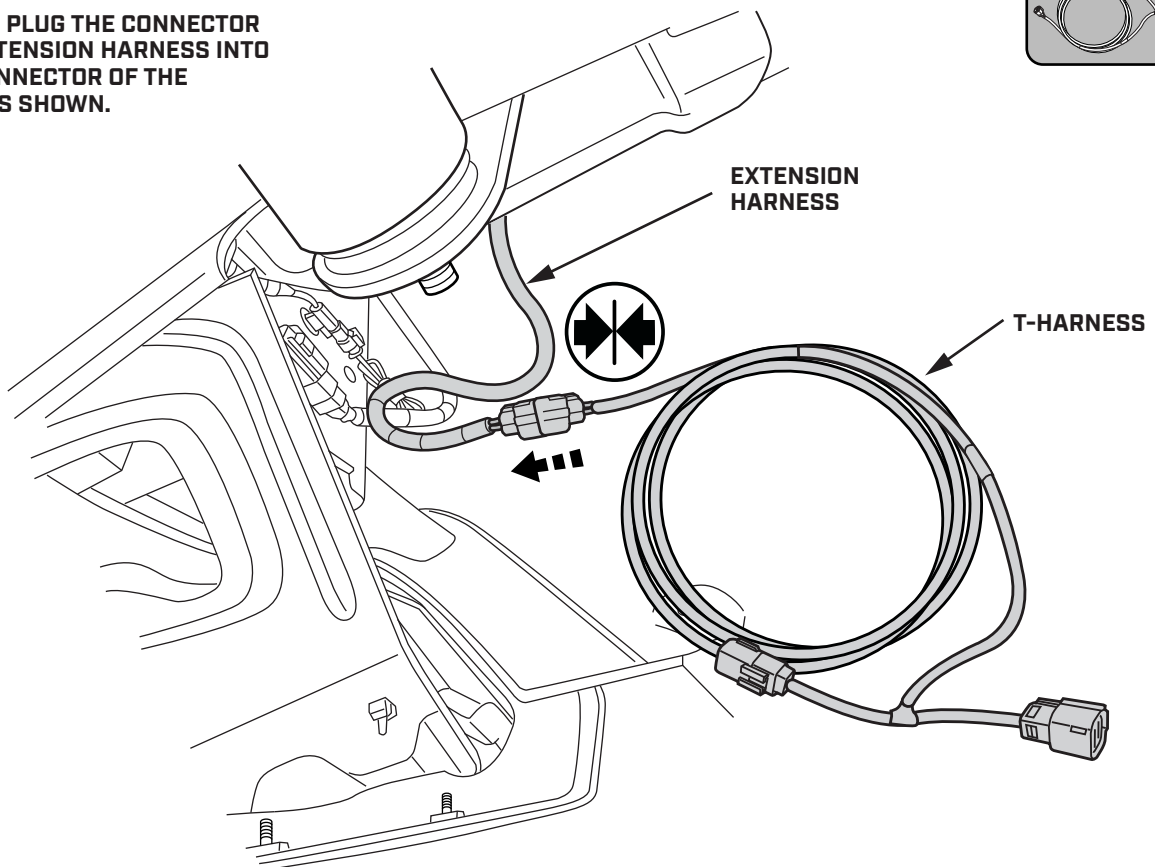
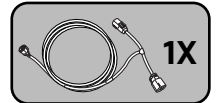

I-SHEET-NA-C3

STEP 40

LOCATE THE BLACK 6-PIN VEHICLE CONNECTOR, CLOSE TO THE DRIVER SIDE TAILLIGHT. PULL BACK ON THE RED TAB, PRESS DOWN ON THE BLACK TAB, AND PULL THE CONNECTORS APART.

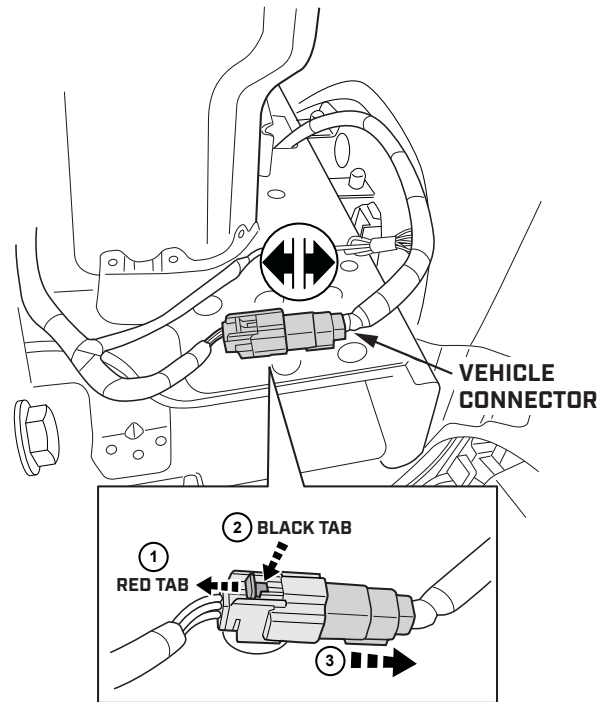
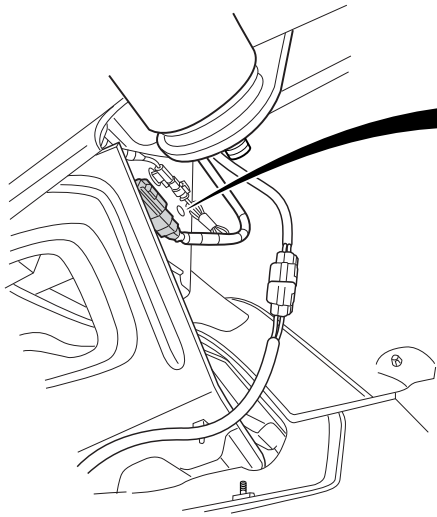

STEP 41

CONNECT THE T-HARNESS FEMALE CONNECTOR TO THE VEHICLE HARNESS MALE CONNECTOR.

CONNECT THE T-HARNESS MALE CONNECTOR TO THE VEHICLE HARNESS FEMALE CONNECTOR.

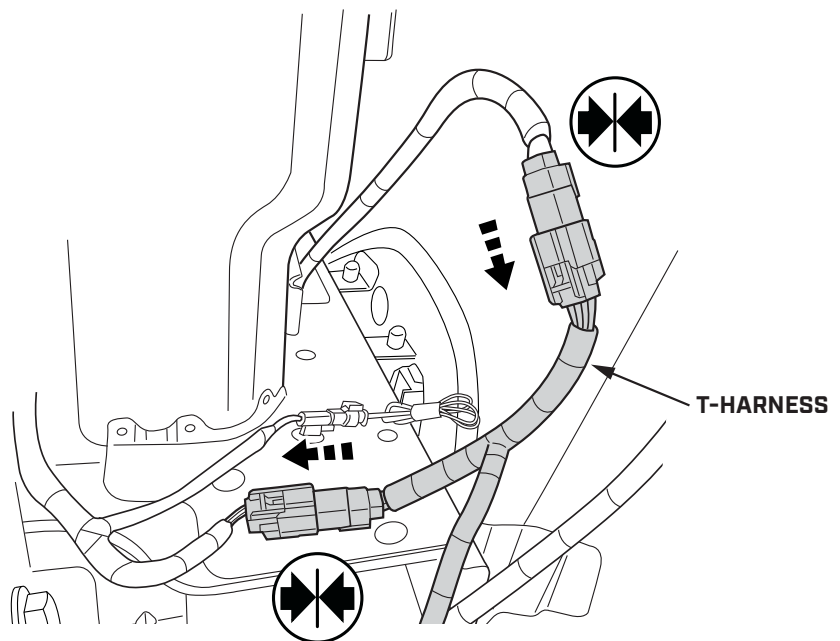

STEP 42



TEST YOUR BRAKE LIGHTS & TURN SIGNALS

- ▼ START THE TRUCK. SOME MODELS MAY TAKE UP TO 30 SECONDS FOR THE VEHICLE TO DETECT THE NEW CONNECTION.
- ▼ CHECK THE BRAKE LIGHTS AND TURN SIGNALS TO BE SURE THEY ARE FUNCTIONING PROPERLY.
- ▼ ONCE YOU HAVE CONFIRMED THAT THE LIGHTS ARE WORKING CORRECTLY, SECURE THE HARNESS WITH CABLE TIES.
- ▼ BE SURE NOT TO INTERFERE WITH ANY MOVING PARTS ON THE VEHICLE.

STEP 43

UNTIE THE THIRD BRAKE LIGHT EXTENSION HARNESS FROM WHERE IT IS ATTACHED TO THE SMARTCAP AT THE LEFT REAR CORNER.

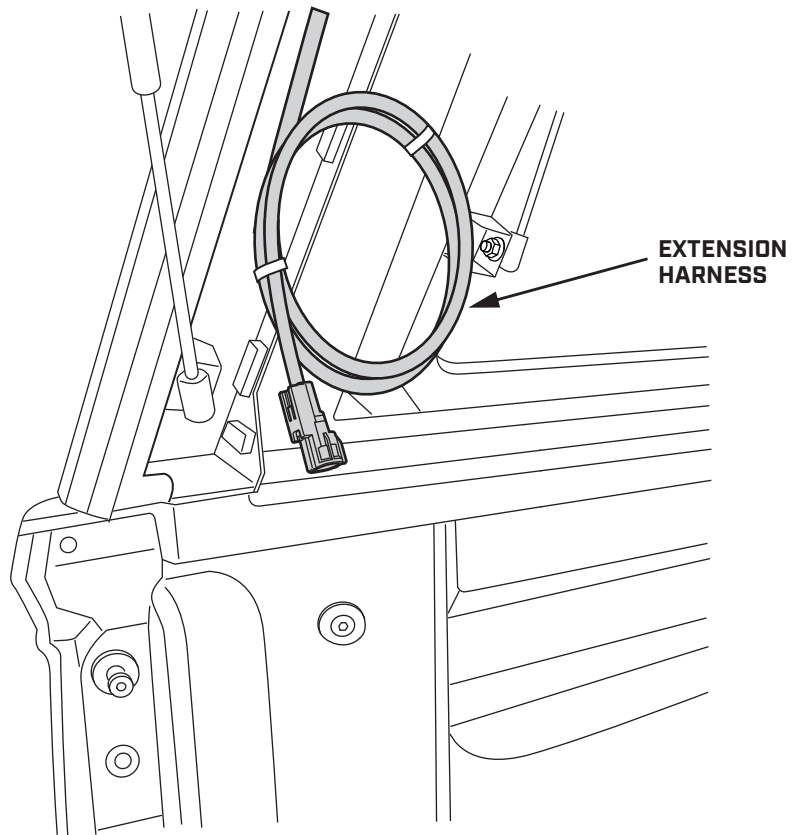

STEP 44

ROUTE THE THIRD BRAKE LIGHT EXTENSION HARNESS IN THROUGH THE BED RAIL OPENING AND DOWN TOWARDS THE REAR BUMPER.

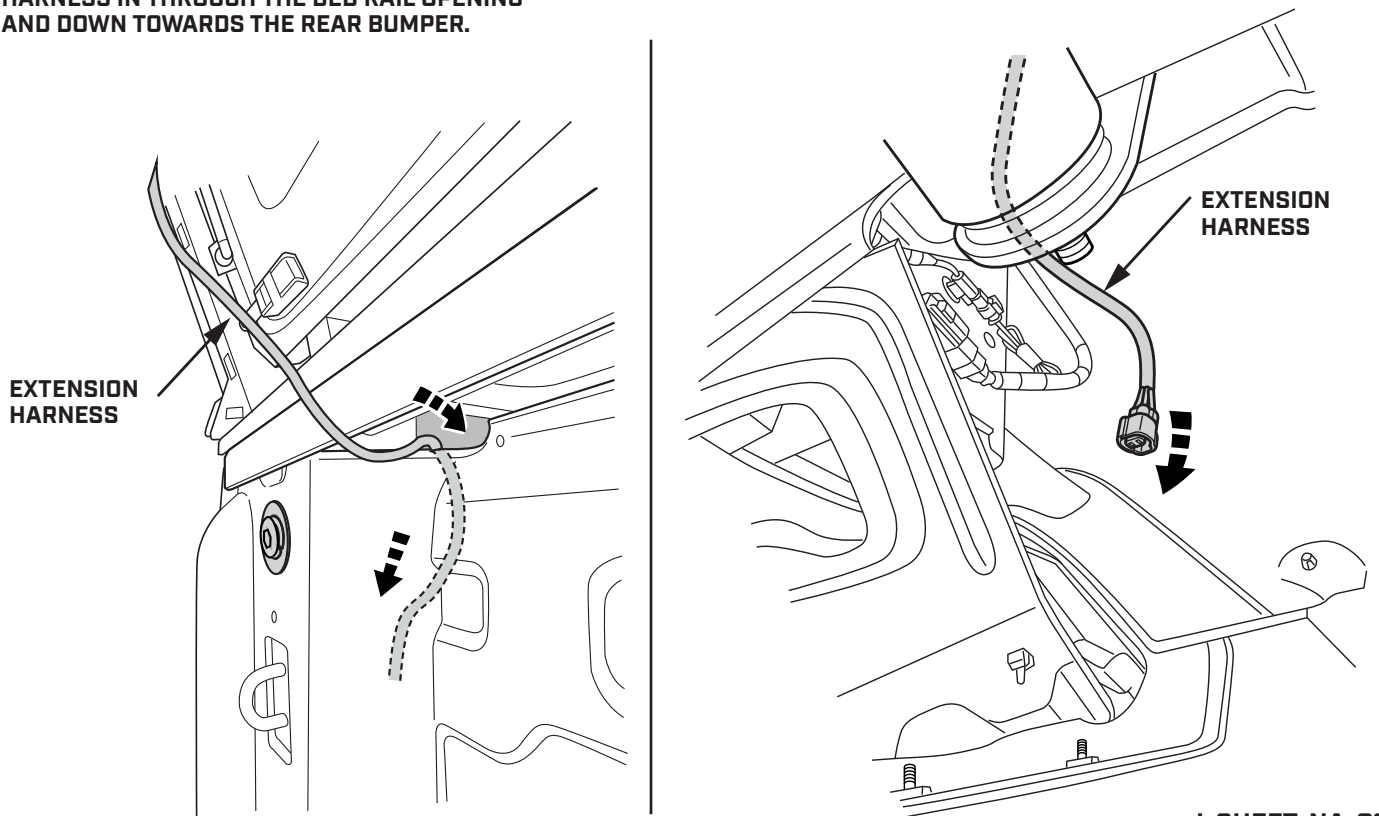

I-SHEET-NA-C3

STEP 45

FROM BELOW, PLUG THE CONNECTOR FROM THE EXTENSION HARNESS INTO THE 2-PIN CONNECTOR OF THE T-HARNESS AS SHOWN.

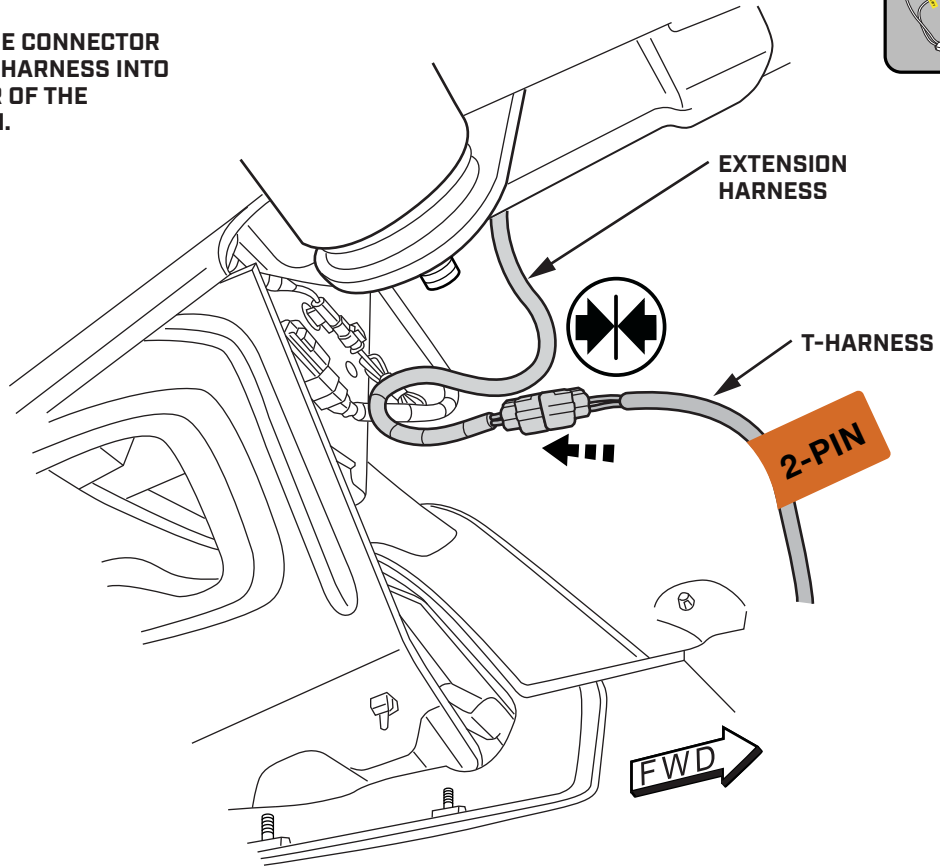
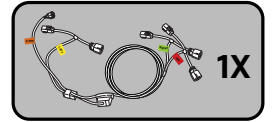

STEP 46

LOCATE THE BLACK 6-PIN VEHICLE CONNECTOR, CLOSE TO THE DRIVER SIDE TAILLIGHT. PULL BACK ON THE RED TAB, PRESS DOWN ON THE BLACK TAB, AND PULL THE CONNECTORS APART.

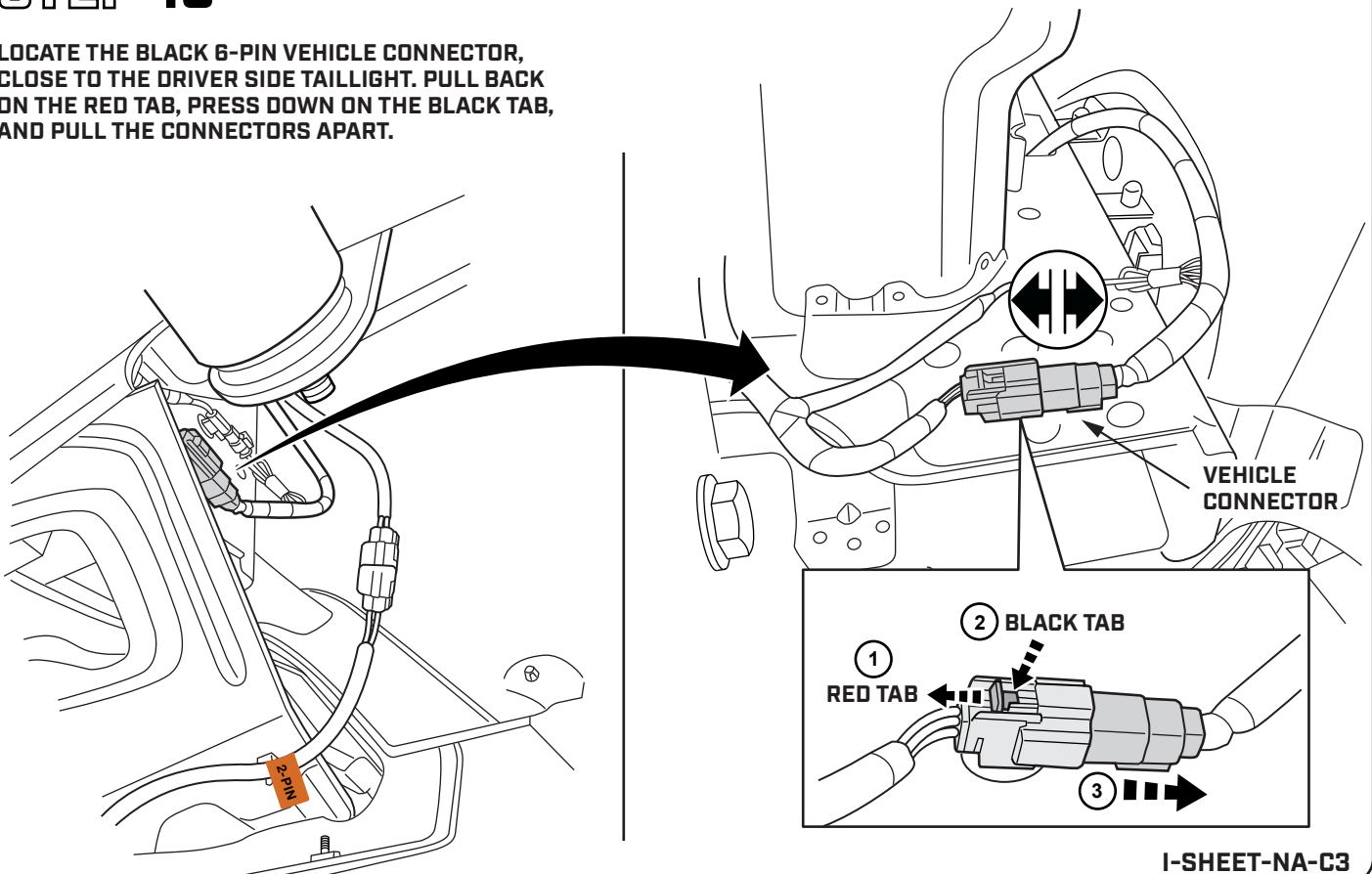

I-SHEET-NA-C3

STEP 47

USING THE END OF THE T-HARNESS LABELED "LEFT", CONNECT THE T-HARNESS FEMALE CONNECTOR TO THE VEHICLE HARNESS MALE CONNECTOR.

CONNECT THE T-HARNESS MALE CONNECTOR TO THE VEHICLE HARNESS FEMALE CONNECTOR.

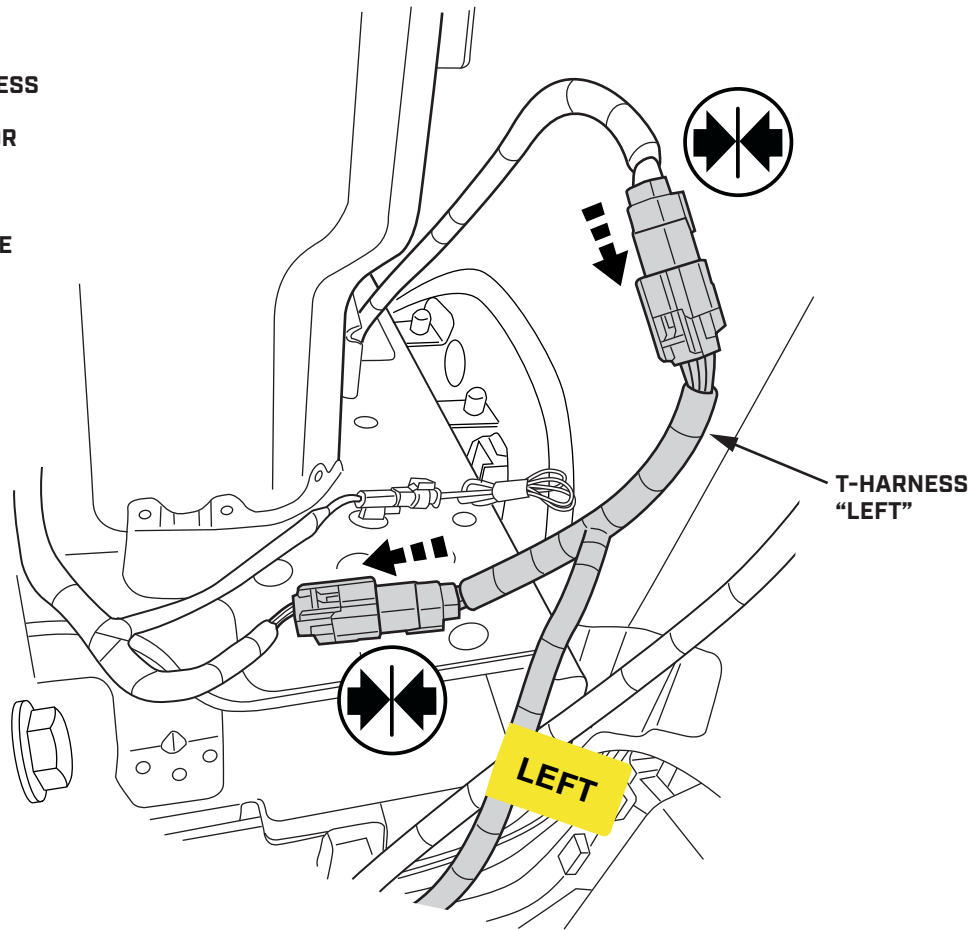

STEP 48

BEGIN ROUTING THE ENDS OF THE T-HARNESS LABELED "RIGHT" AND "12V" TOWARDS THE RIGHT SIDE OF THE TRUCK. ROUTE THE HARNESS ABOVE THE CHASSIS AS SHOWN.

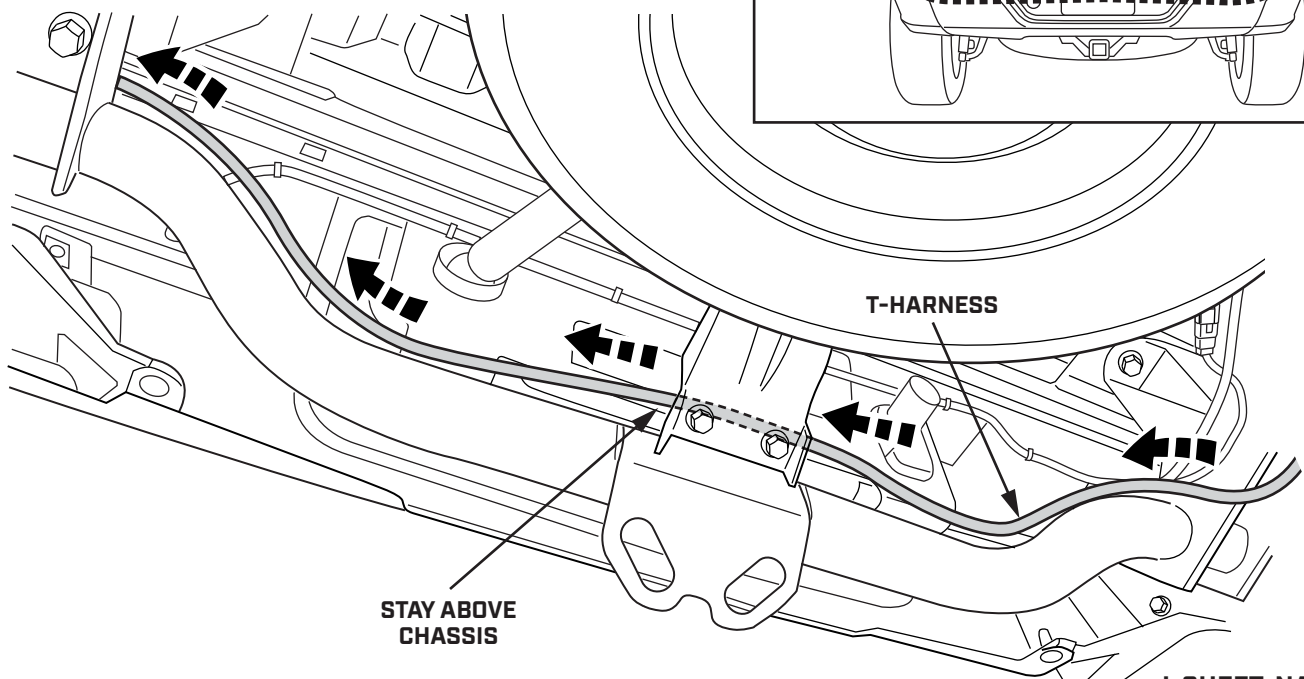

I-SHEET-NA-C3

STEP 49

CONTINUE ROUTING THE HARNESS TOWARDS THE TAILPIPE.

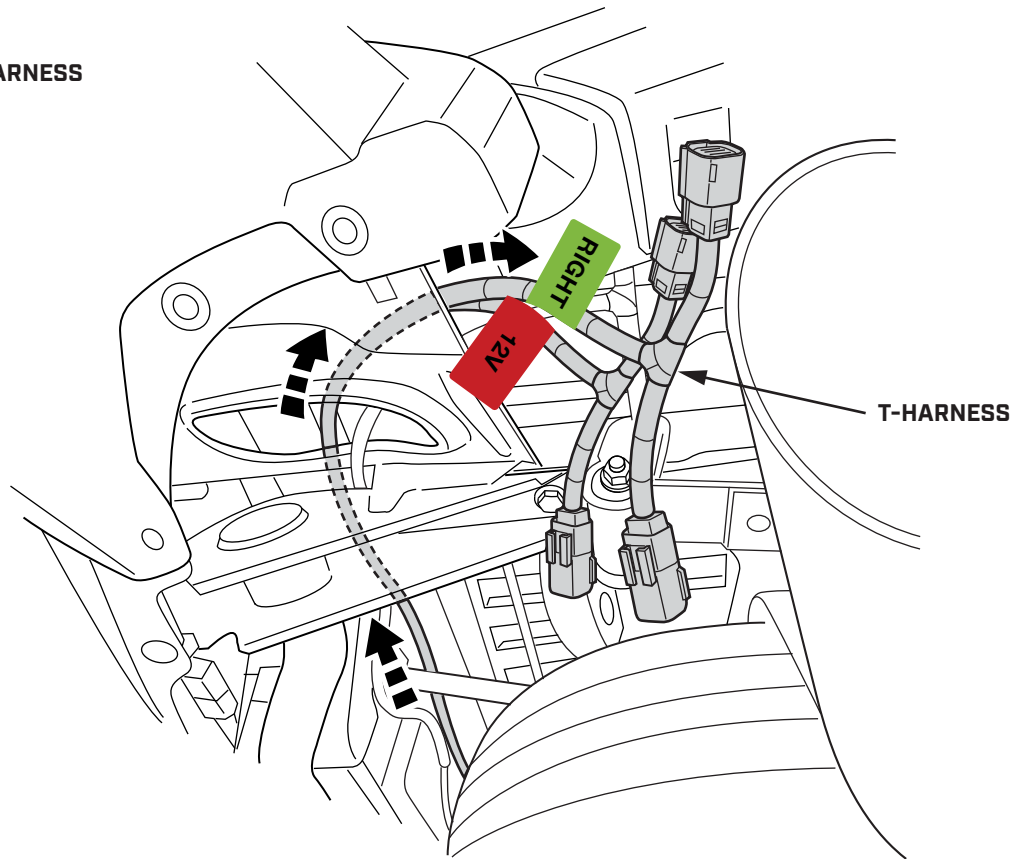

STEP 50

LOCATE THE 6-PIN VEHICLE CONNECTOR ON THE PASSENGER SIDE OF THE TRUCK, CLOSE TO THE TAILLIGHT. PULL BACK ON THE RED TAB, PRESS DOWN ON THE BLACK TAB, AND PULL THE CONNECTORS APART.

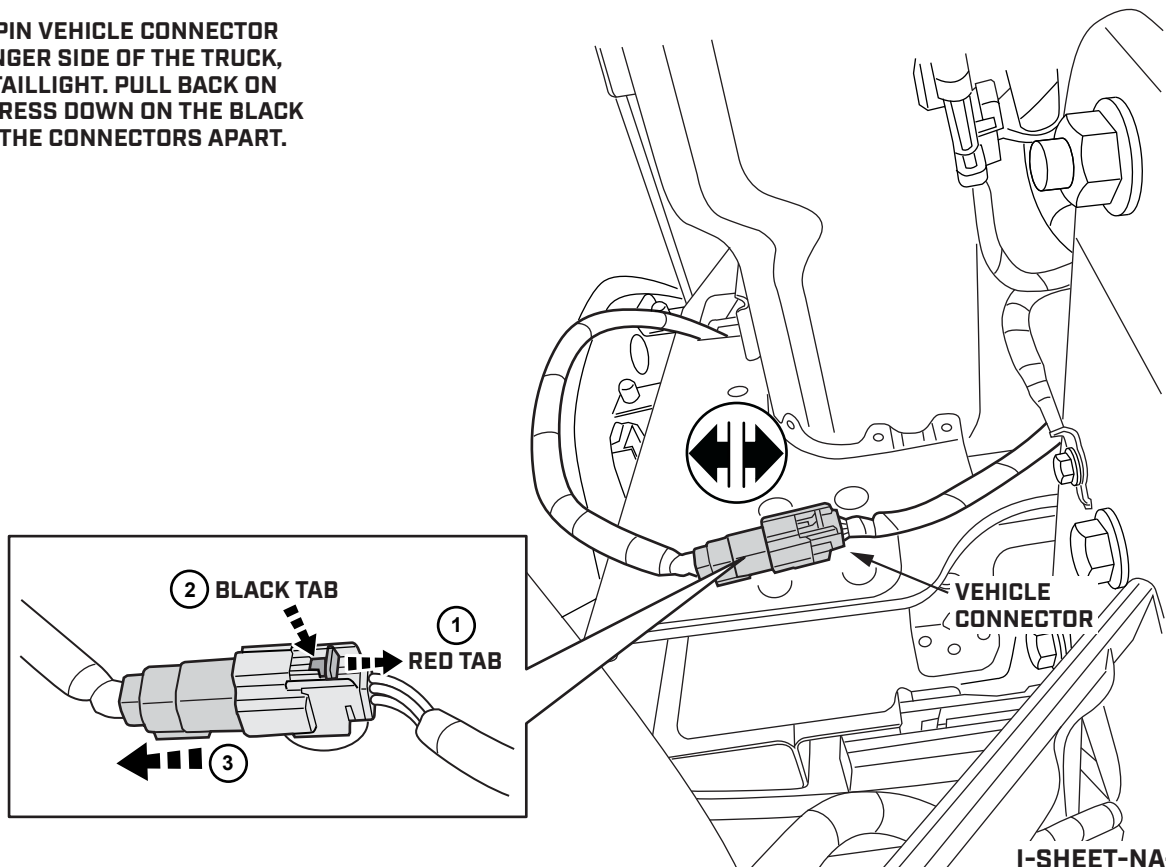

I-SHEET-NA-C3

STEP 51

USING THE END OF THE T-HARNESS LABELED "RIGHT", CONNECT THE T-HARNESS FEMALE CONNECTOR TO THE VEHICLE HARNESS MALE CONNECTOR.

CONNECT THE T-HARNESS MALE CONNECTOR TO THE VEHICLE HARNESS FEMALE CONNECTOR.

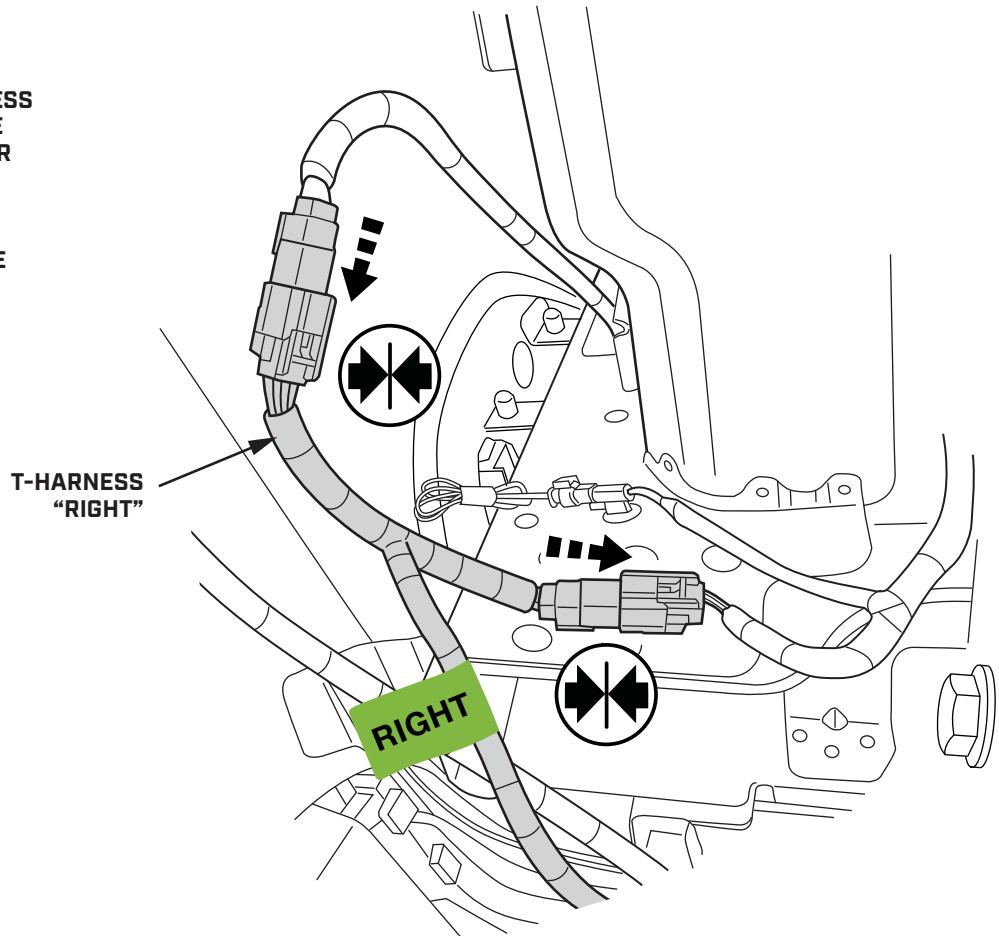

STEP 52

LOCATE THE 6-PIN VEHICLE CONNECTOR ON THE ORANGE AUXILIARY CABLE. PULL BACK ON THE RED TAB, PRESS DOWN ON THE BLACK TAB, AND PULL THE CONNECTORS APART.

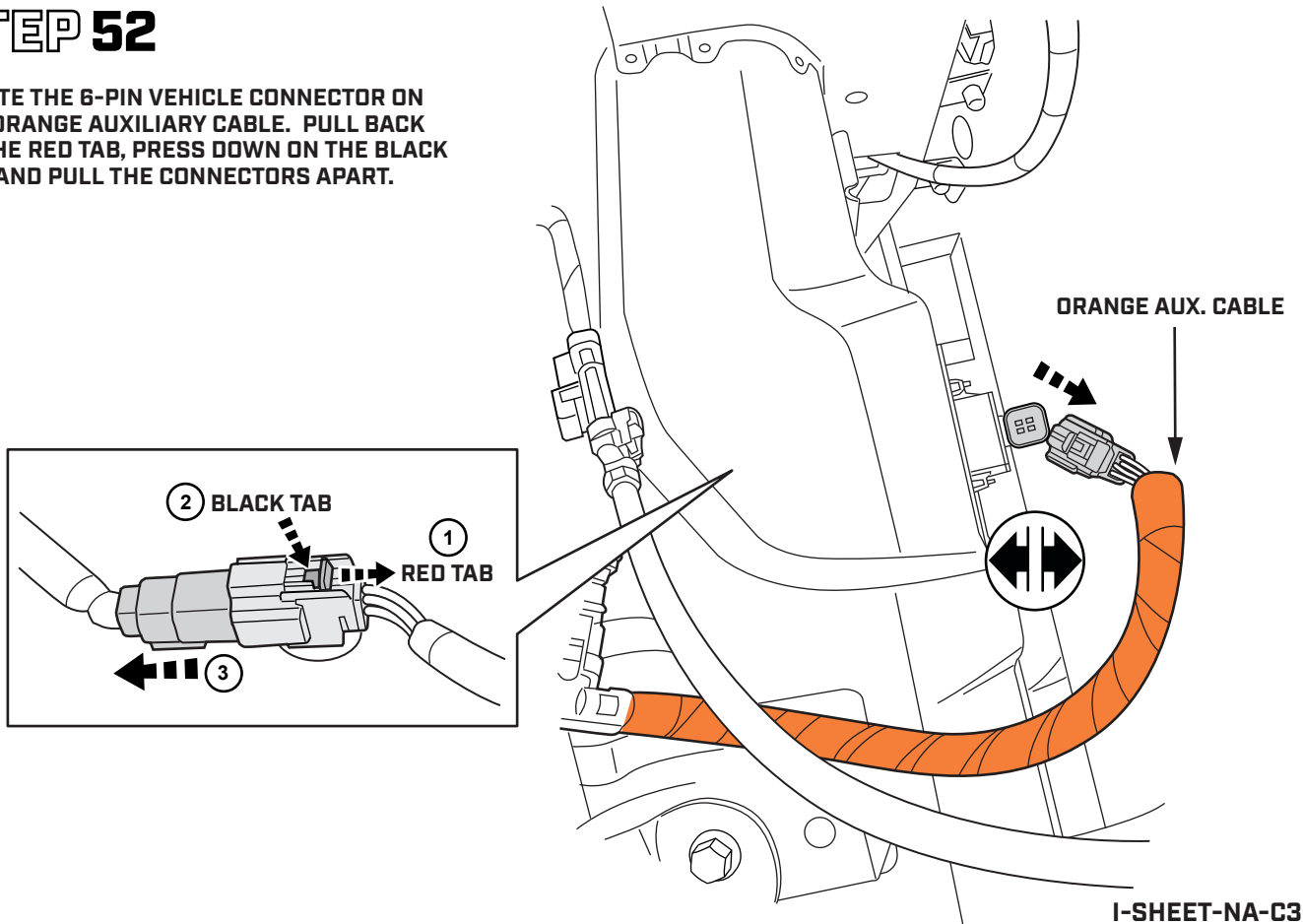

I-SHEET-NA-C3

STEP 53

USING THE END OF THE T-HARNESS LABELED "12V", CONNECT THE T-HARNESS FEMALE CONNECTOR TO THE VEHICLE HARNESS MALE CONNECTOR.

CONNECT THE T-HARNESS MALE CONNECTOR TO THE VEHICLE HARNESS FEMALE CONNECTOR.

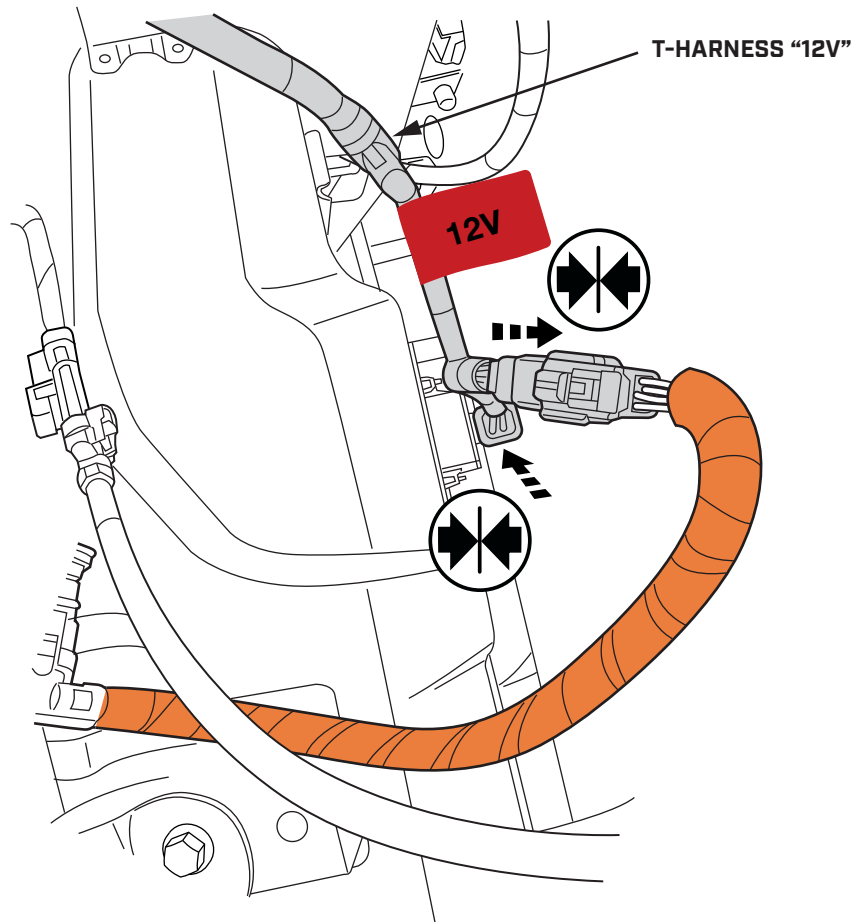

STEP 54



TEST YOUR BRAKE LIGHTS & TURN SIGNALS

- ▼ START THE TRUCK. SOME MODELS MAY TAKE UP TO 30 SECONDS FOR THE VEHICLE TO DETECT THE NEW CONNECTION.
- ▼ CHECK THE BRAKE LIGHTS AND TURN SIGNALS TO BE SURE THEY ARE FUNCTIONING PROPERLY.
- ▼ ONCE YOU HAVE CONFIRMED THAT THE LIGHTS ARE WORKING CORRECTLY, SECURE THE HARNESS WITH CABLE TIES.
- ▼ BE SURE NOT TO INTERFERE WITH ANY MOVING PARTS ON THE VEHICLE.



SMARTCAP[®]

THANKS FOR YOUR PURCHASE.
PLEASE LET US KNOW IF YOU HAVE ANY QUESTIONS.

SMARTCAP.COM - SUPPORT.NA@SMARTCAP.COM - NORTH AMERICA

