

SMARTCAP®

INSTRUCTION GUIDE

GM CANYON/COLORADO EDITION

2023

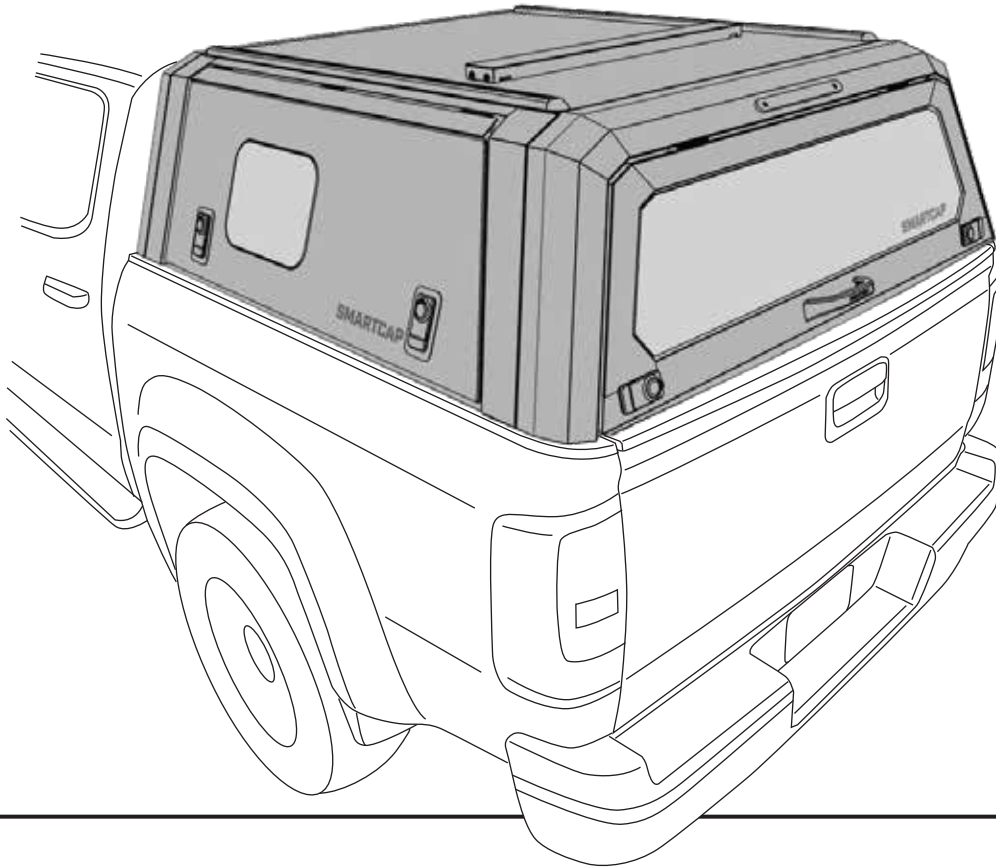

- ▼ **PREPARE A CLEAN WORK AREA.**
- ▼ **WE RECOMMEND A MINIMUM OF 2 PEOPLE FOR ASSEMBLY AND 4 PEOPLE FOR INSTALLATION.**
- ▼ **ENSURE THE REQUIRED TOOLS ARE PRESENT AND ALL HARDWARE CONTENTS ARE ACCOUNTED FOR.**
- ▼ **NEVER USE ACETONE OR THINNERS ON PAINTED PARTS.**
- ▼ **READ THROUGH THE ENTIRE INSTRUCTION GUIDE BEFORE STARTING THIS PROCEDURE AND FOLLOW THE STEPS CAREFULLY TO AVOID ANY DAMAGE TO THE COMPONENTS OR THE VEHICLE.**

SMARTCAP.COM - SUPPORT.NA@SMARTCAP.COM - NORTH AMERICA



I-SHEET-NA-C2

TOOLS REQUIRED

Combination
Wrench

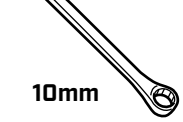

10mm

Torque
Wrench



10mm Socket

Allen Key



6mm Allen Key
6mm Hex Socket

Utility
Knife



Scissors



Super Glue



IMPORTANT

- ▼ USE ONLY THE TOOLS RECOMMENDED ABOVE.
- ▼ USE ONLY THE HARDWARE PROVIDED IN THIS KIT.
- ▼ ASSISTANCE WILL BE NEEDED FOR THIS INSTALLATION.
FOUR PEOPLE ARE RECOMMENDED TO LIFT THE SMARTCAP ONTO THE VEHICLE.
- ▼ AVOID PINCHING OR CRUSHING HANDS AND FINGERS.
- ▼ INSPECT ALL KIT COMPONENTS FOR DAMAGE BEFORE ASSEMBLY.
- ▼ NEVER USE ACETONE OR THINNERS ON PAINTED PARTS.

COMPONENTS

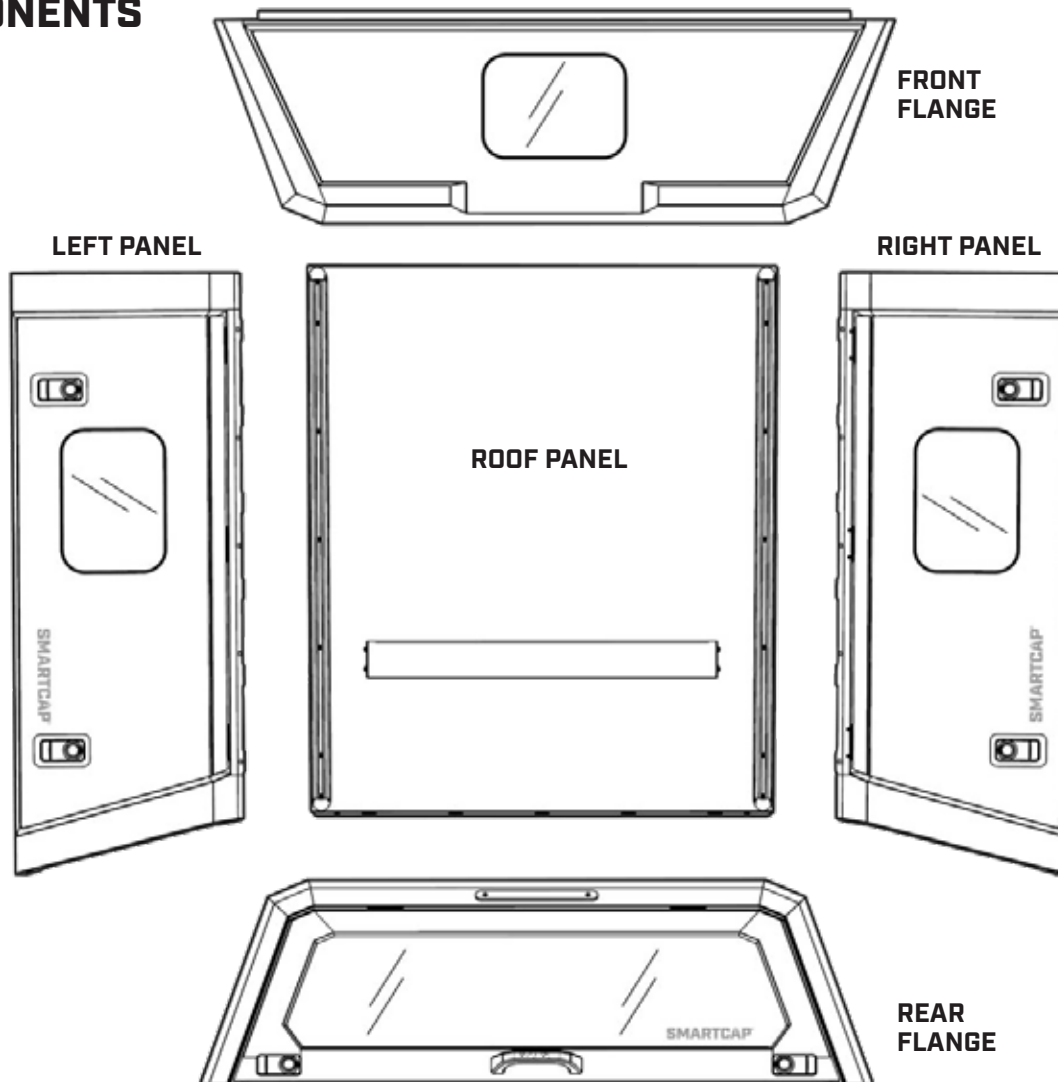

I-SHEET-NA-C2

ASSEMBLY HARDWARE

FITMENT KIT

M6 BOLT

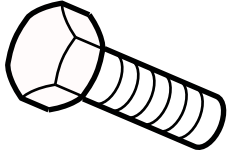

30X

**FASTENER
BLOCK CLAMP**

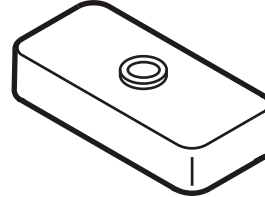

30X

**M6 LOCK
WASHER**

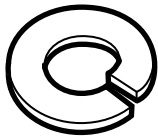

30X

**FASTENER
BLOCK**

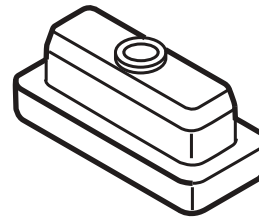

30X

D - RUBBER



1X

SPARE PARTS

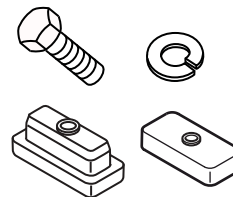

2X

PRE-FASTENED TO ROOF PANEL

**M6 FENDER
WASHER**

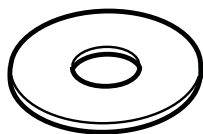

10X

M6 LOCK NUT

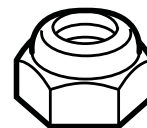

10X

STEP 1



IMPORTANT

2 PERSON JOB



- ▼ BE SURE TO REMOVE ALL FIVE PANELS FROM THEIR PACKAGING AND INSPECT THE PAINTED SURFACES PRIOR TO ASSEMBLY, AS SMARTCAP WILL NOT ACCEPT WARRANTY CLAIMS AFTER ASSEMBLY IS COMPLETED. IF MANUFACTURING IMPERFECTIONS OR SHIPPING DAMAGES ARE FOUND, DO NOT CONTINUE WITH THE ASSEMBLY PROCESS AND CONTACT SUPPORT.NA@SMARTCAP.COM.

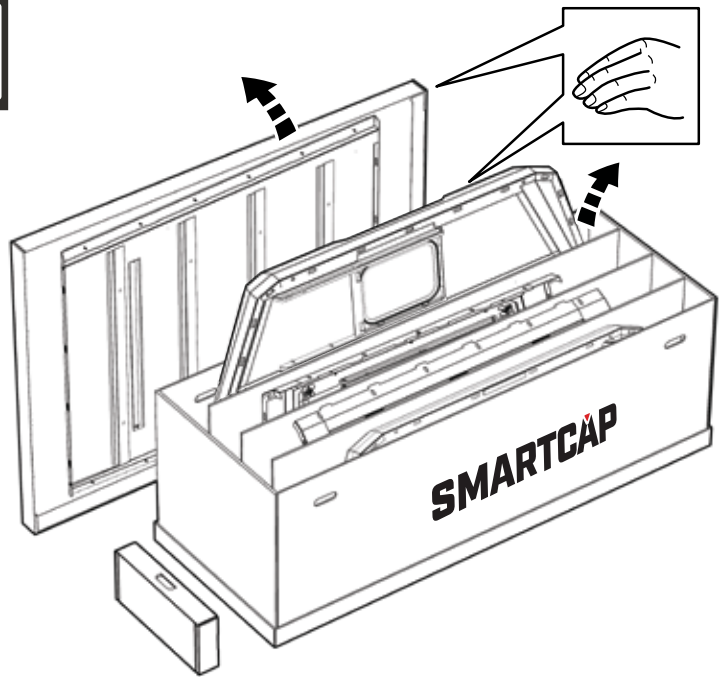

STEP 2

PLACE THE ROOF PANEL WHERE YOU PLAN TO ASSEMBLE THE CAP. REMOVE THE LID FROM THE PACKAGING AND PLACE IT NEXT TO THE ROOF PANEL.

LOGO SIDE UP

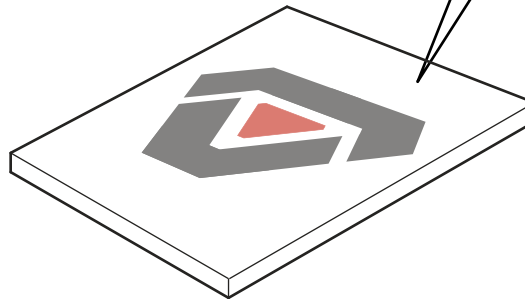

USE LID AS WORK SURFACE

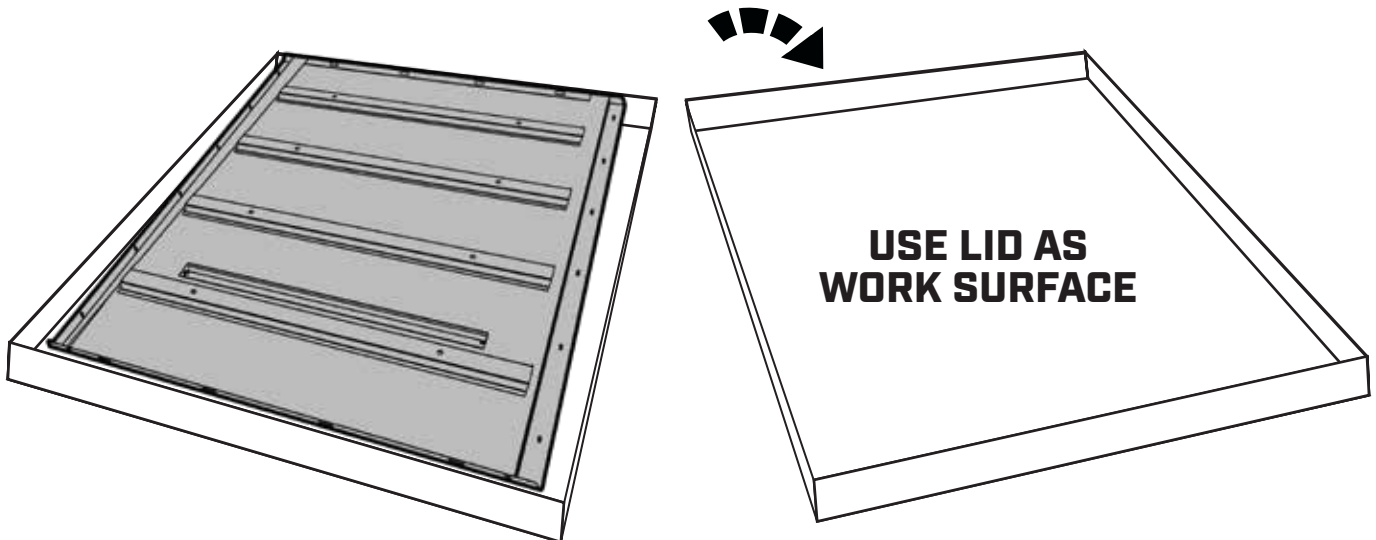

I-SHEET-NA-C2

STEP 3

USE A 10MM COMBINATION WRENCH TO REMOVE ALL HARDWARE FROM THE ROOF PANEL AND SAVE FOR REUSE.



AIR VENT INDICATES REAR

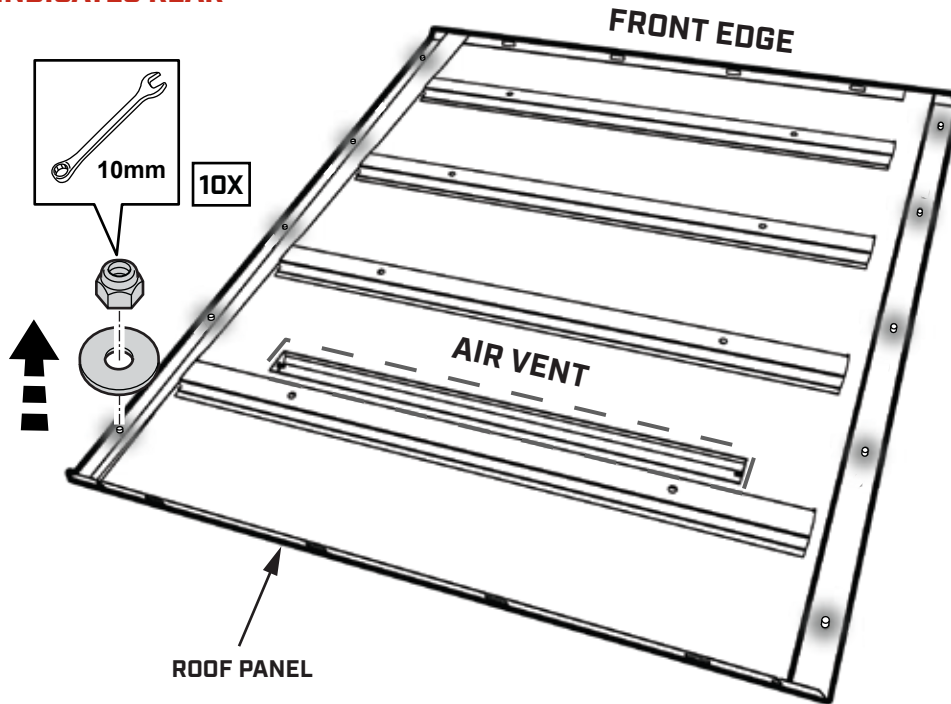

STEP 4

LOCATE THE RIGHT PANEL IN THE SMARTCAP PACKAGE AND BRING IT TO YOUR WORK AREA.



THE SLANTED EDGE INDICATES REAR

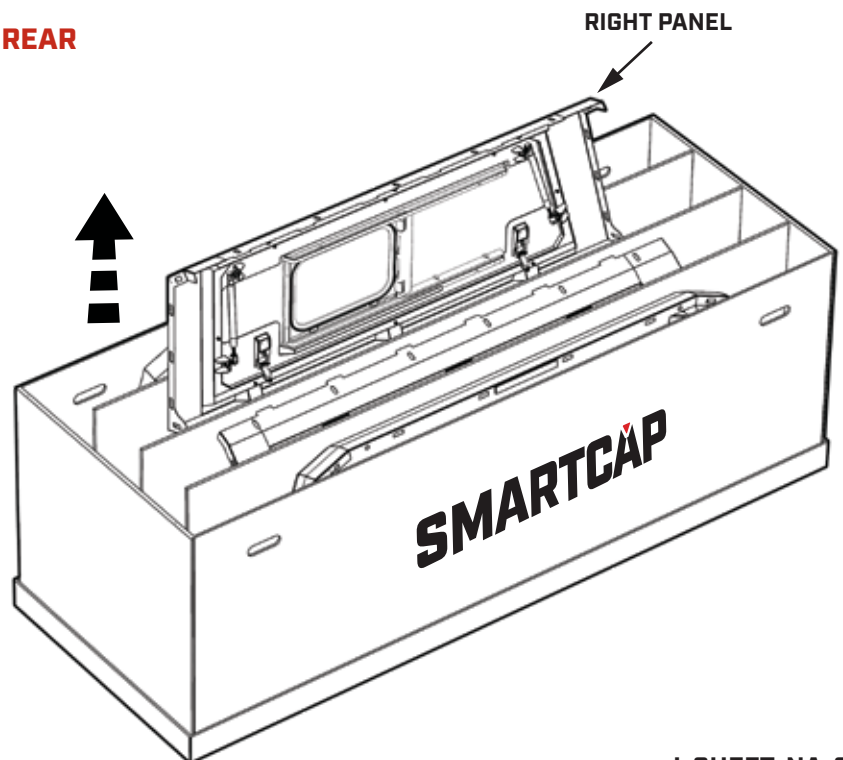

STEP 5

INSERT PANEL TABS INTO NARROW SLOTS JUST ABOVE FOAM PADDING ON ROOF PANEL.

TAP FIRMLY WITH PALM OF HAND UNTIL THERE IS A 2-3MM GAP.

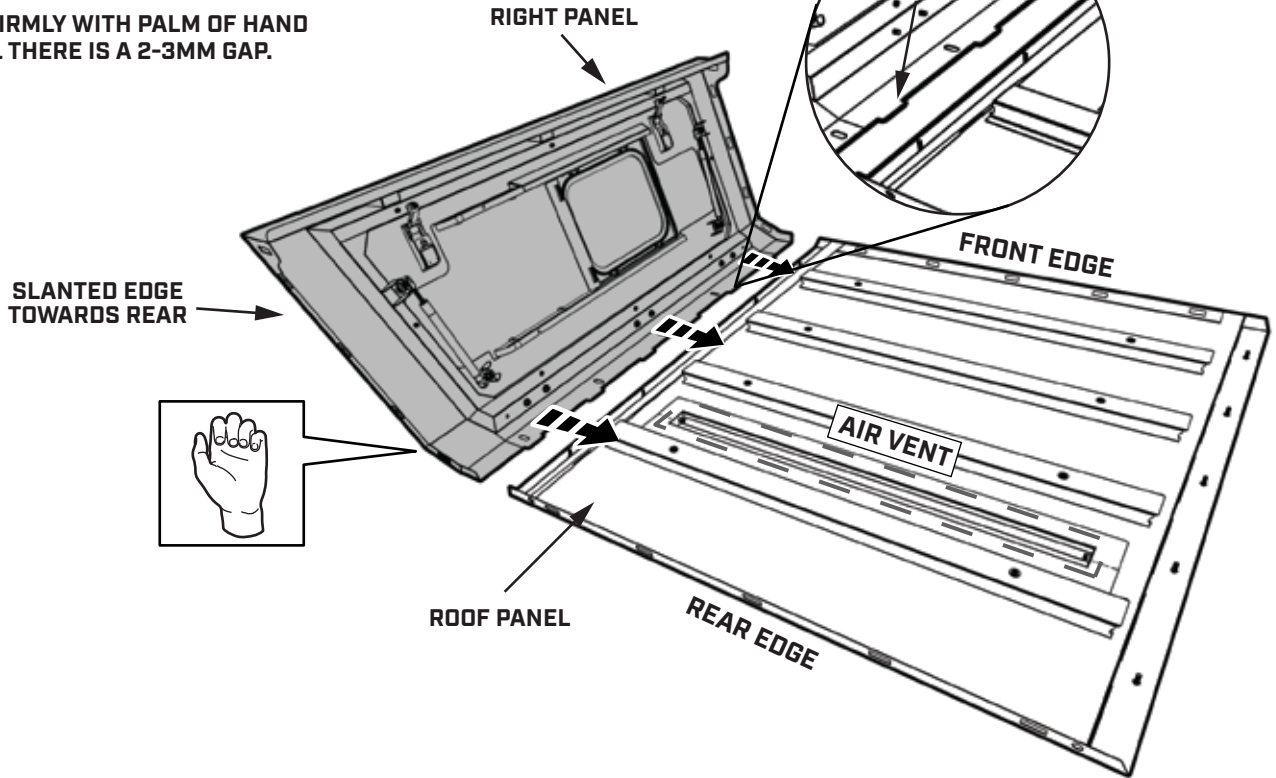

STEP 6

HAND TIGHTEN M6 LOCK NUT WITH M6 FENDER WASHER TO ALL BOLTS.

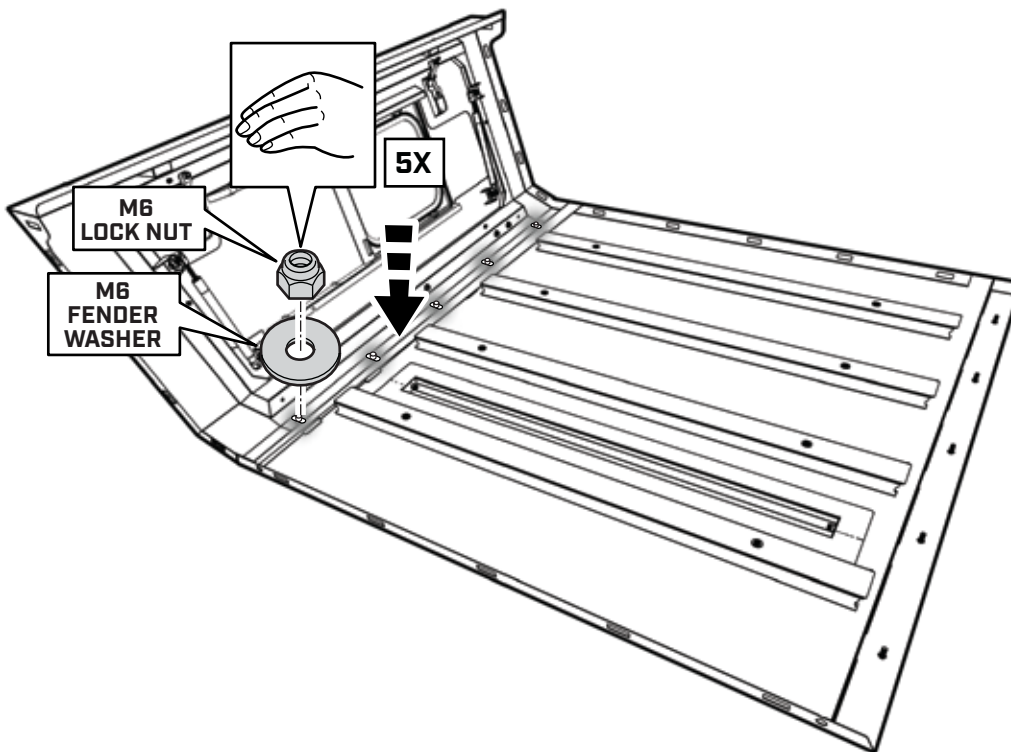

STEP 7

LOCATE THE LEFT PANEL IN THE SMARTCAP PACKAGE AND BRING IT TO YOUR WORK AREA.



THE SLANTED EDGE INDICATES REAR

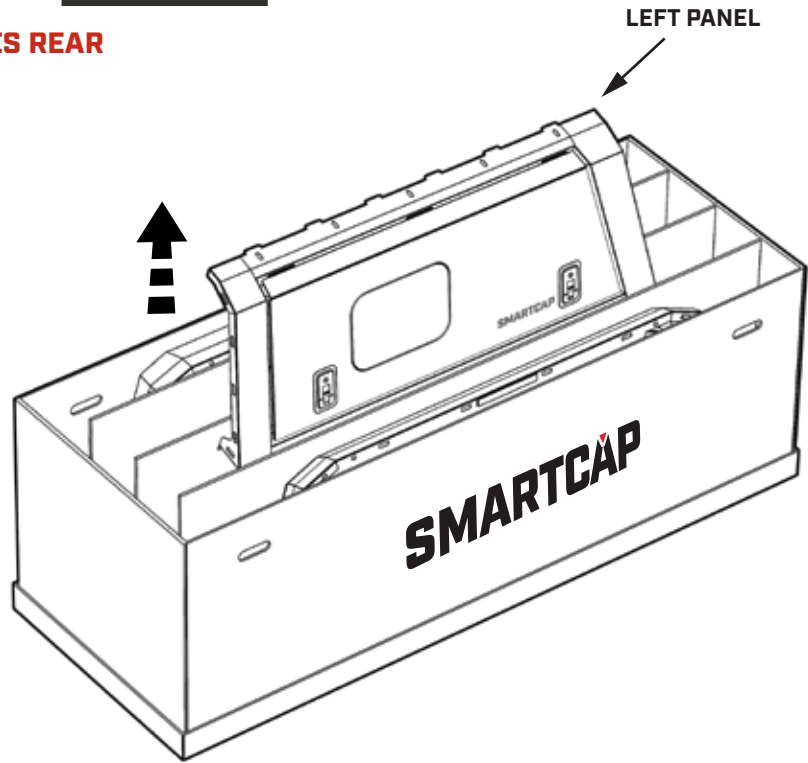
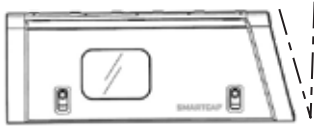

STEP 8

INSERT PANEL TABS INTO NARROW SLOTS JUST ABOVE FOAM PADDING ON ROOF PANEL.



TAP FIRMLY WITH PALM OF HAND UNTIL THERE IS A 2-3MM GAP.

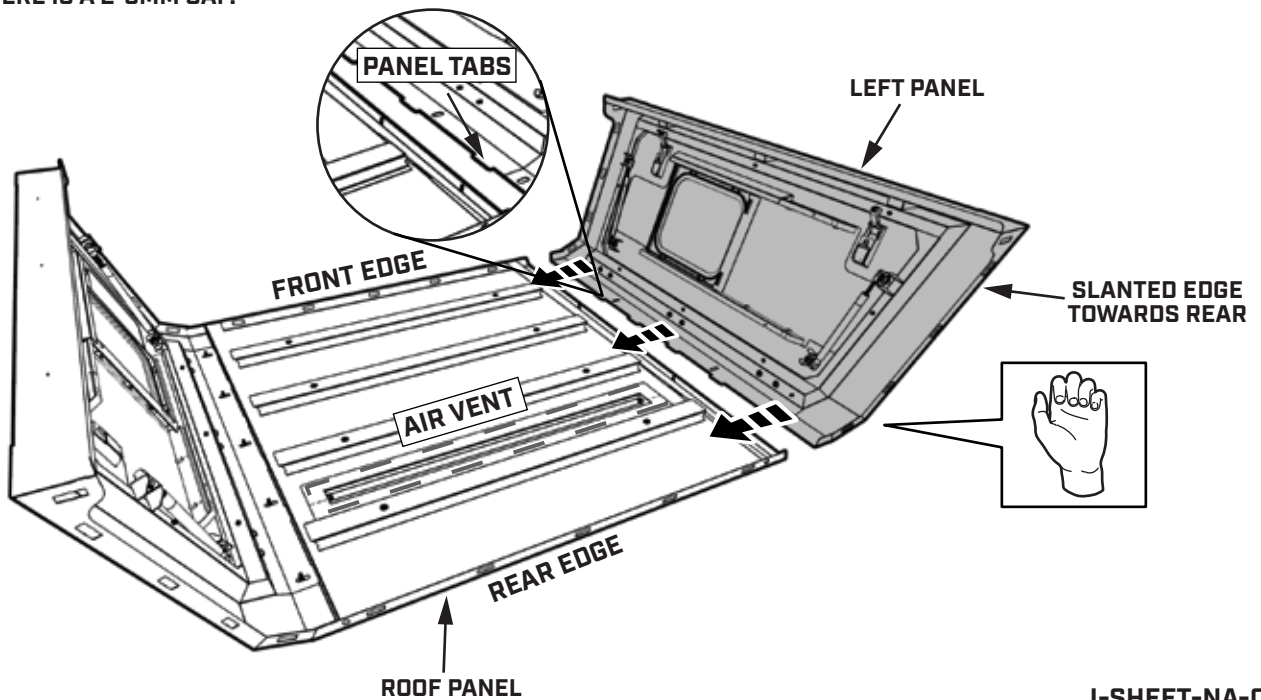

I-SHEET-NA-C2

STEP 9

HAND TIGHTEN M6 LOCK NUT WITH M6 FENDER WASHER TO ALL BOLTS.

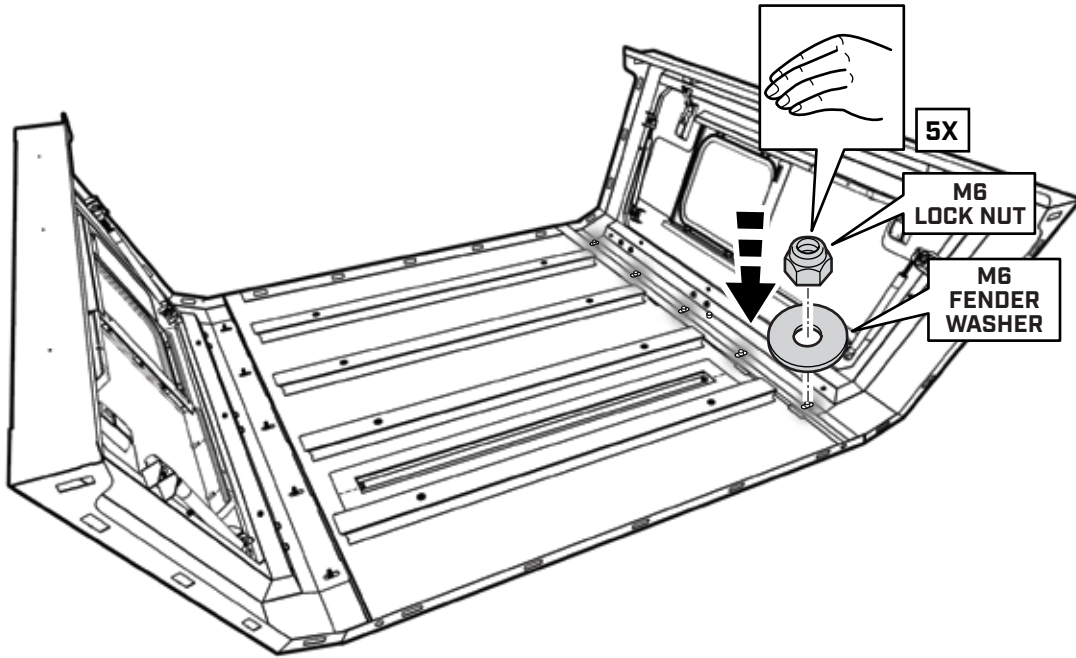

STEP 10

PUSH THE SMARTCAP TO EXPOSE A FEW INCHES OF STYROFOAM UNDERNEATH THE ROOF PANEL TO PROVIDE SUPPORT FOR THE FRONT FLANGE.

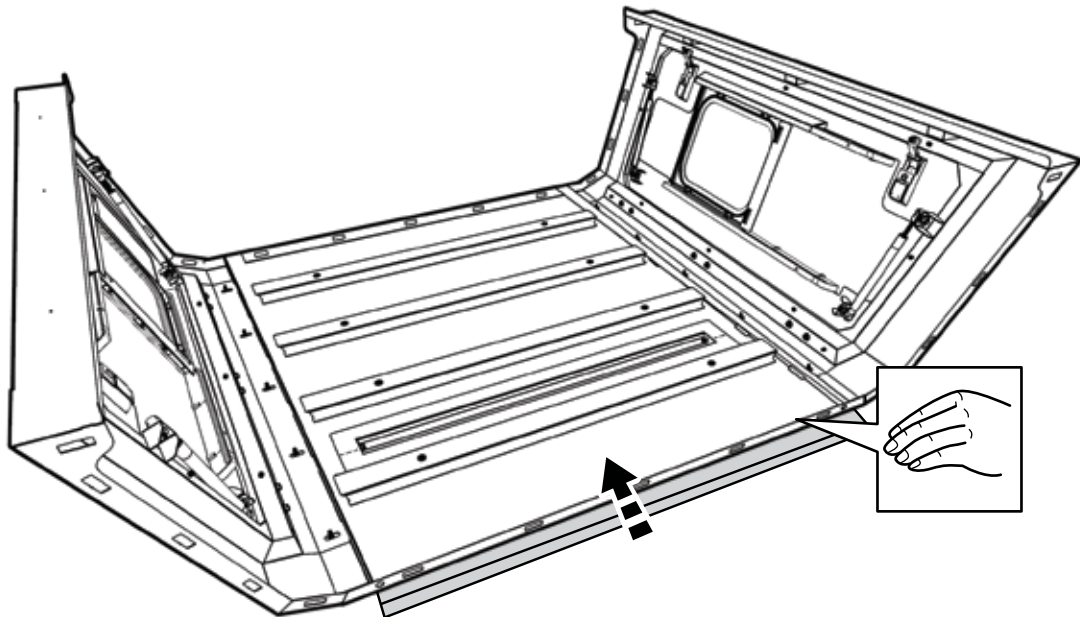

I-SHEET-NA-C2

STEP 11

RETRIEVE THE NECESSARY HARDWARE FROM THE FITMENT KIT.

LOCATE THE FRONT FLANGE IN THE SMARTCAP PACKAGE AND BRING IT TO YOUR WORK AREA.

2 PERSON JOB

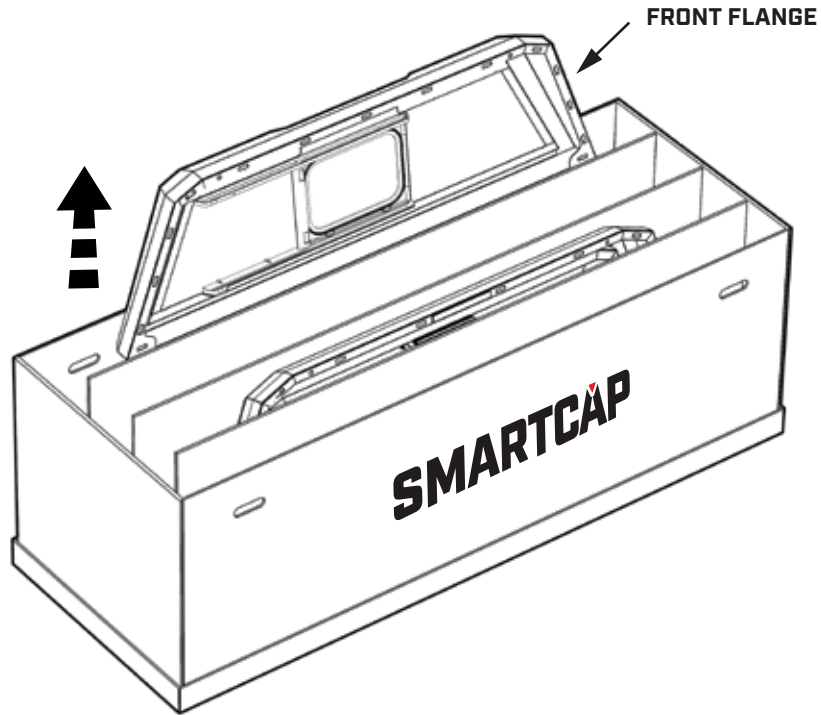

STEP 12

PLACE FRONT FLANGE AS SHOWN BELOW.

2 PERSON JOB

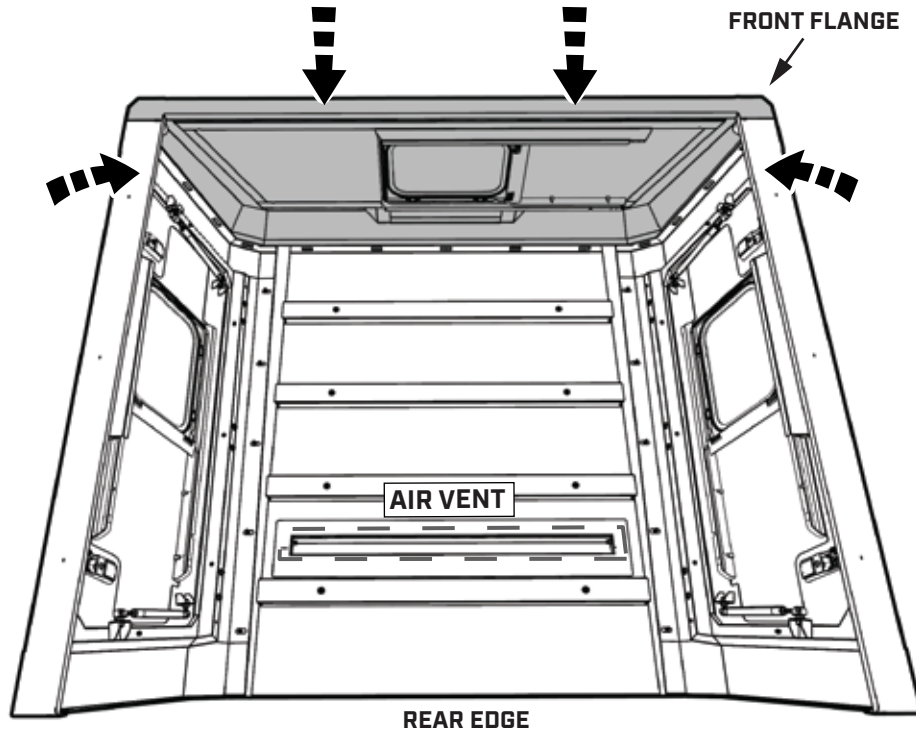

I-SHEET-NA-C2

STEP 13

INSTALL HARDWARE ALONG FRONT FLANGE WITH M6 BOLT ON INSIDE.

START WITH ASSEMBLING FASTENER BLOCKS 1-5.

ADJUST LEFT AND RIGHT PANELS TO ALIGN FASTENER BLOCKS 6-15 FOR ASSEMBLY.

HAND TIGHTEN IN THE SEQUENCE SHOWN.

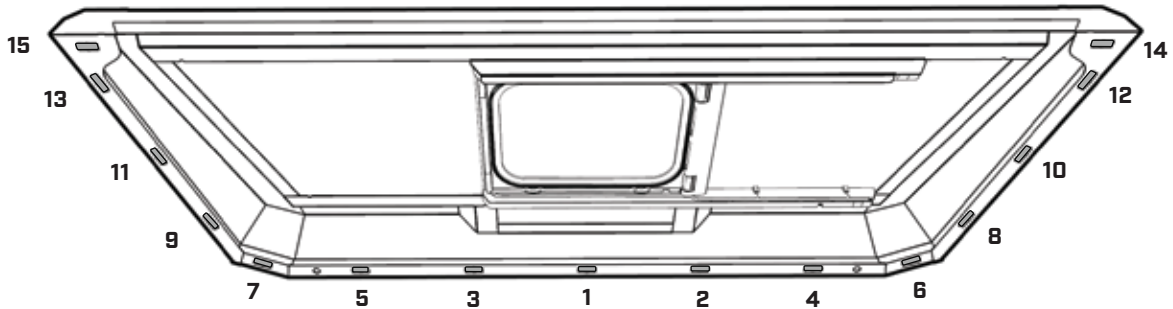
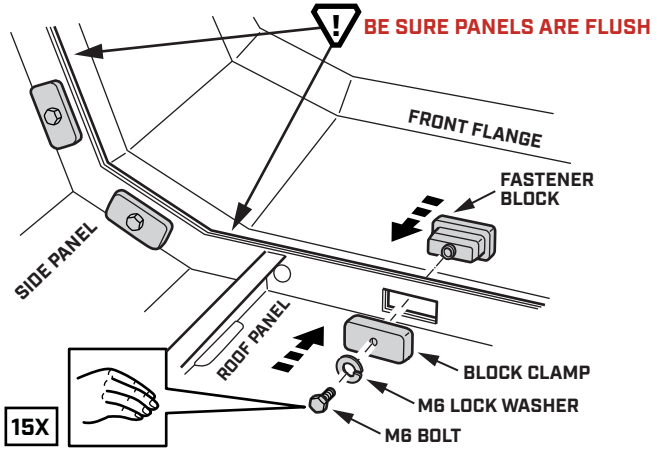

STEP 14

PUSH THE SMARTCAP TO EXPOSE A FEW INCHES OF STYROFOAM UNDERNEATH THE ROOF PANEL TO PROVIDE SUPPORT FOR THE REAR FLANGE.

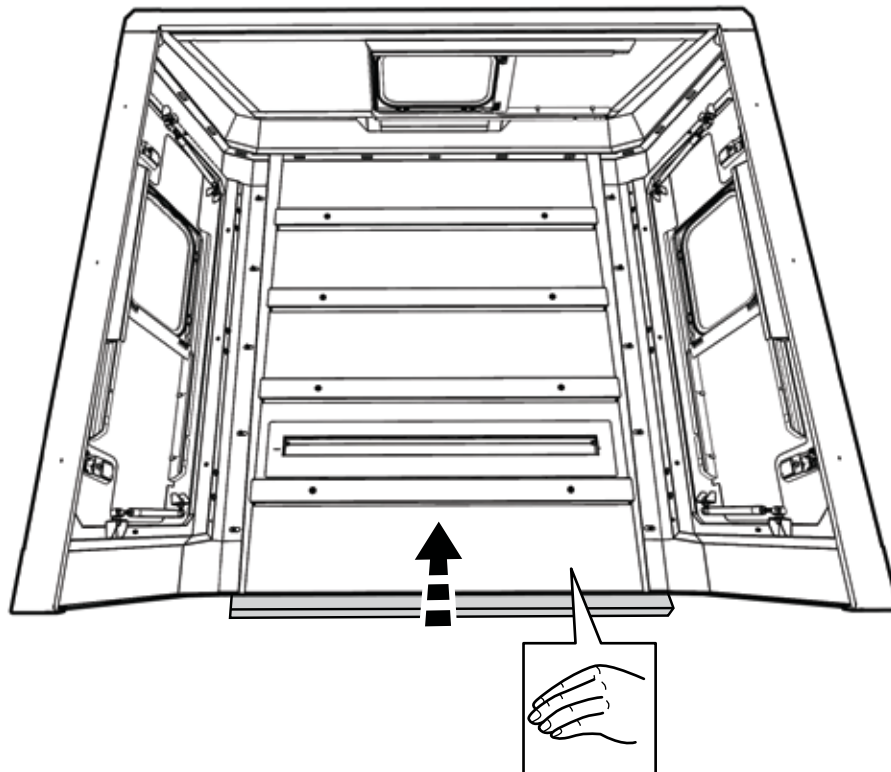

I-SHEET-NA-C2

STEP 15

RETRIEVE THE NECESSARY HARDWARE FROM THE FITMENT KIT.

LOCATE THE REAR FLANGE IN THE SMARTCAP PACKAGE AND BRING IT TO YOUR WORK AREA.

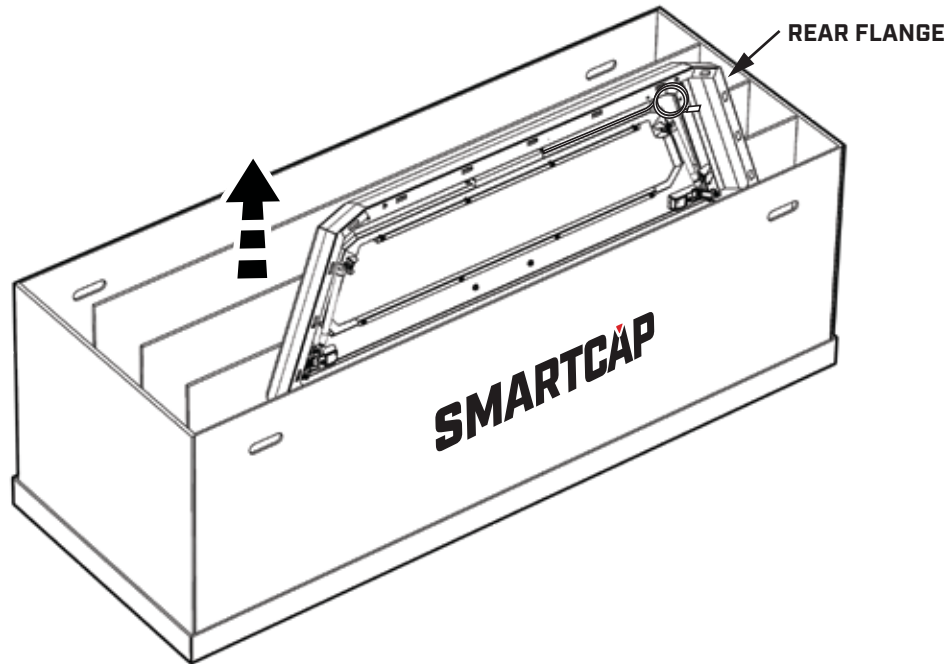
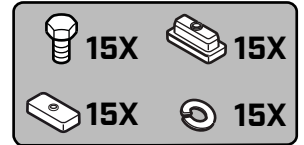

STEP 16

PLACE REAR FLANGE AS SHOWN BELOW.

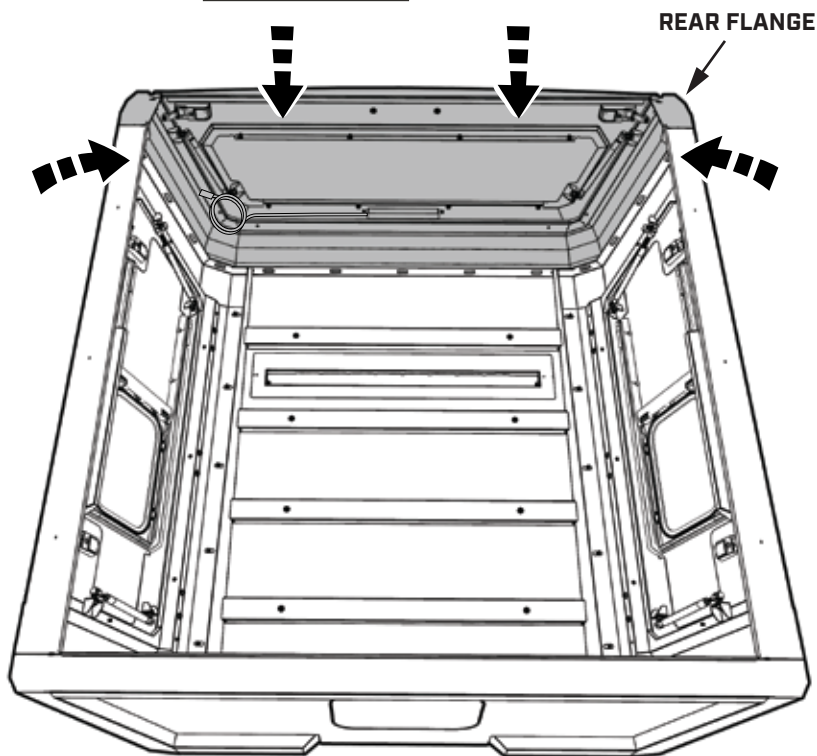

I-SHEET-NA-C2

STEP 17

INSTALL HARDWARE ALONG REAR FLANGE WITH BOLT ON INSIDE.

START WITH ASSEMBLING FASTENER BLOCKS 1-5.

ADJUST LEFT AND RIGHT PANELS TO ALIGN FASTENER BLOCKS 6-15 FOR ASSEMBLY.

HAND TIGHTEN IN THE SEQUENCE SHOWN.

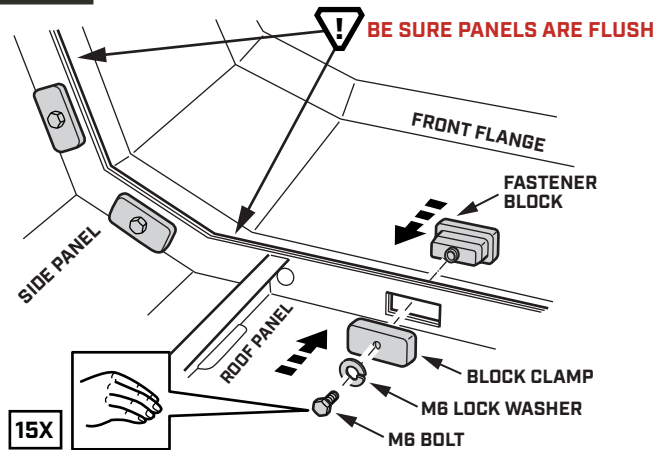

STEP 18

TIGHTEN ALL HARDWARE WITH TORQUE WRENCH AND 10MM SOCKET TO 3.7 FT. LBS. [5 NEWTON METERS]



[3.7 ft. lbs]/[5 Nm]

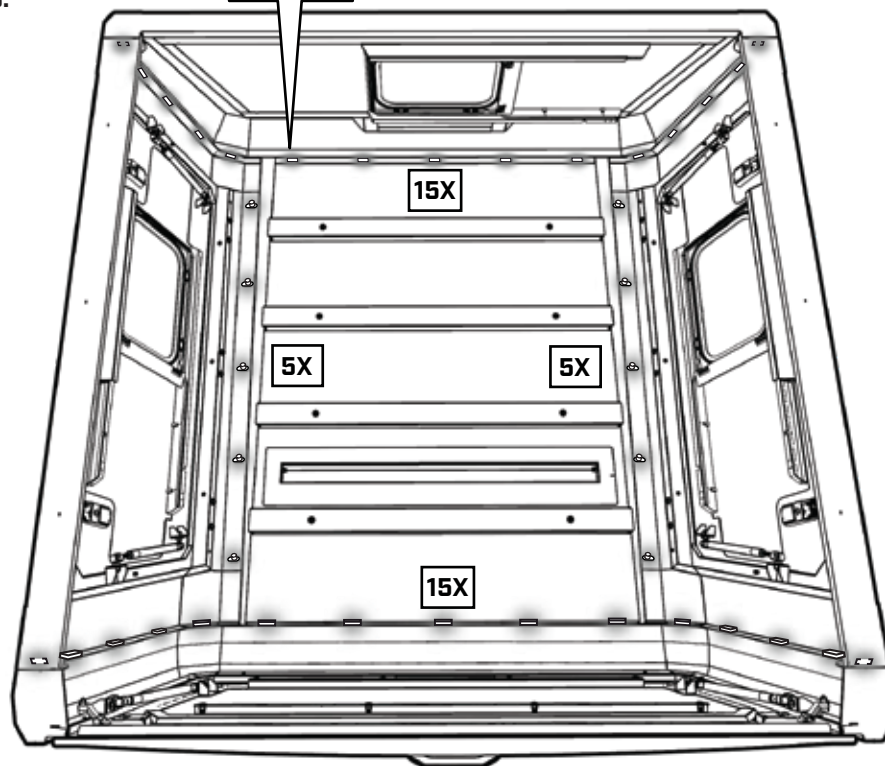

I-SHEET-NA-C2

STEP 19

A LOCATE THE D-RUBBER RETENTION TAB NEXT TO THE REAR DOOR GASKET.

BEND THE TAB UPWARDS AT A 45 DEGREE ANGLE.

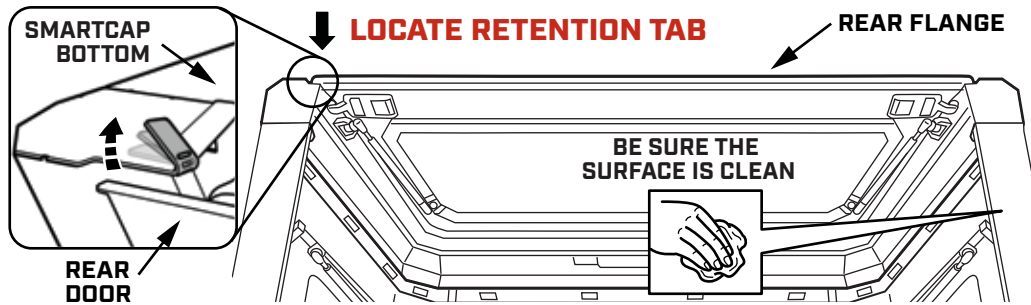

B PEEL AWAY A SMALL PORTION OF THE ADHESIVE BACKING FROM THE D-RUBBER.

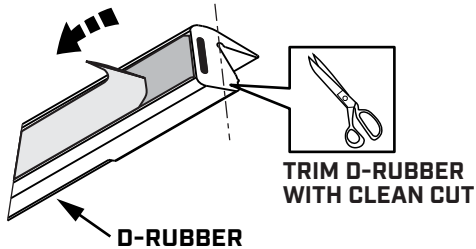

C INSERT THE TAB INTO THE D-RUBBER UNTIL THE D-RUBBER LIGHTLY BUTTS UP AGAINST REAR DOOR GASKET.

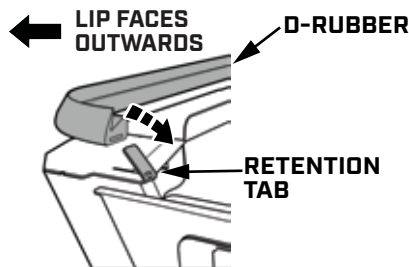

D FIRMLY PUSH THE TAB BACK DOWN TO SECURE THE D-RUBBER IN PLACE.

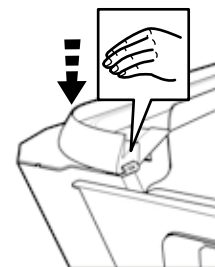

CORRECT D-RUBBER ORIENTATION

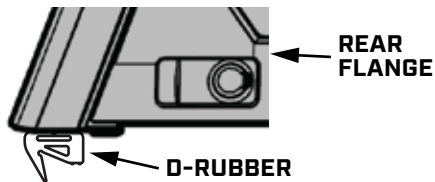

INCORRECT D-RUBBER ORIENTATION

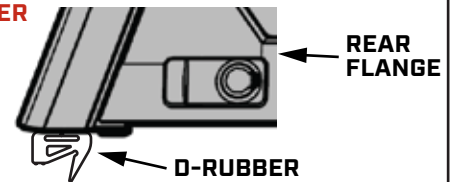

STEP 20

PEEL AWAY ADHESIVE BACKING IN SHORT LENGTHS AS YOU WORK AROUND THE EDGES.

STAY WITHIN 1/8" FROM THE OUTER EDGES.

REMOVE EXCESS WITH A STRAIGHT CUT.

REINFORCE ENDS WITH SUPER GLUE.

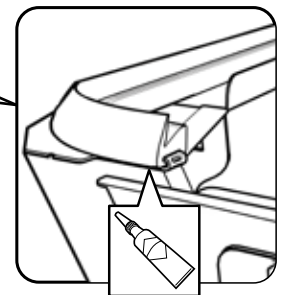
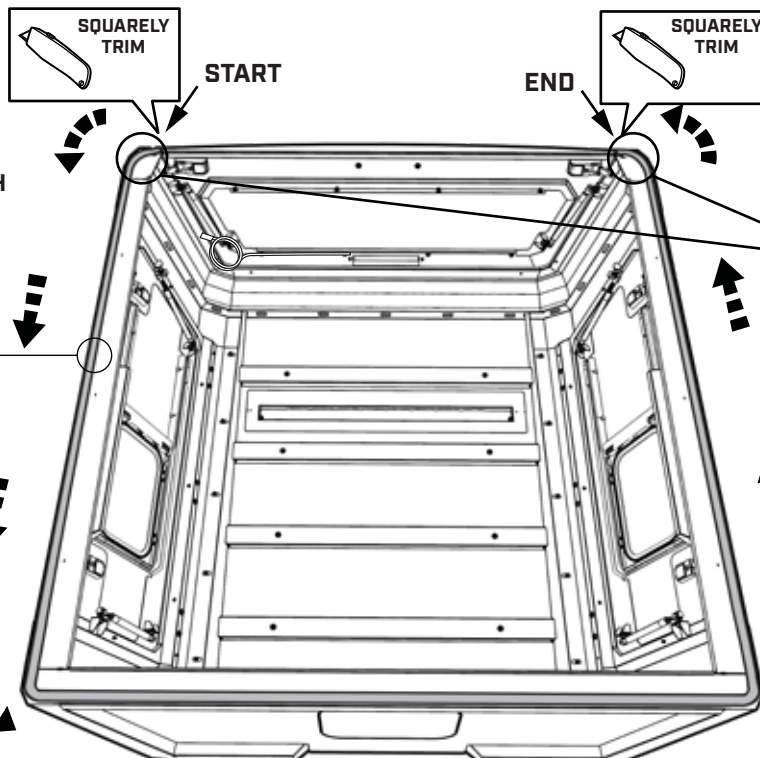
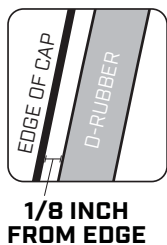

REINFORCE THE FIRST AND LAST 2" OF EACH END WITH SUPER GLUE

INSTALLATION HARDWARE

MOUNTING BRACKETS

REAR
BRACKETS
[SHORT]
LEFT AND RIGHT

2X

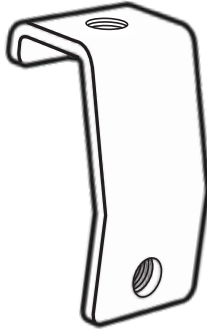

FRONT
BRACKETS
[LONG]
LEFT AND RIGHT

2X



THICK RUBBER PAD

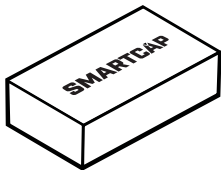

8X

5mm FOAM SEAL TAPE

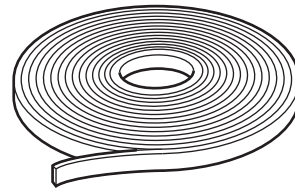

1X

M10 BUTTON BOLT



8X

M10 LOCK WASHER



8X

M10 FENDER WASHER



8X



IMPORTANT

- ▼ ASSISTANCE WILL BE NEEDED FOR THIS INSTALLATION. FOUR PEOPLE ARE RECOMMENDED TO LIFT THE SMARTCAP ONTO THE VEHICLE.
- ▼ AVOID PINCHING OR CRUSHING HANDS AND FINGERS.
- ▼ READ THROUGH THE ENTIRE PROCEDURE BEFORE STARTING.

STEP 21

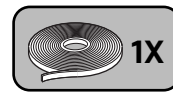

INSPECT THE TRUCK BED. IF FRONT EDGE IS LOWER THAN THE SIDES, ADD FOAM SEAL TAPE TO THE FRONT EDGE OF THE BED.

NOTE: IF SLOPE IS PRESENT, USE THE EXCESS FOAM SEAL TAPE AND APPLY TO EACH SIDE TO LEVEL OUT THE FRONT EDGE

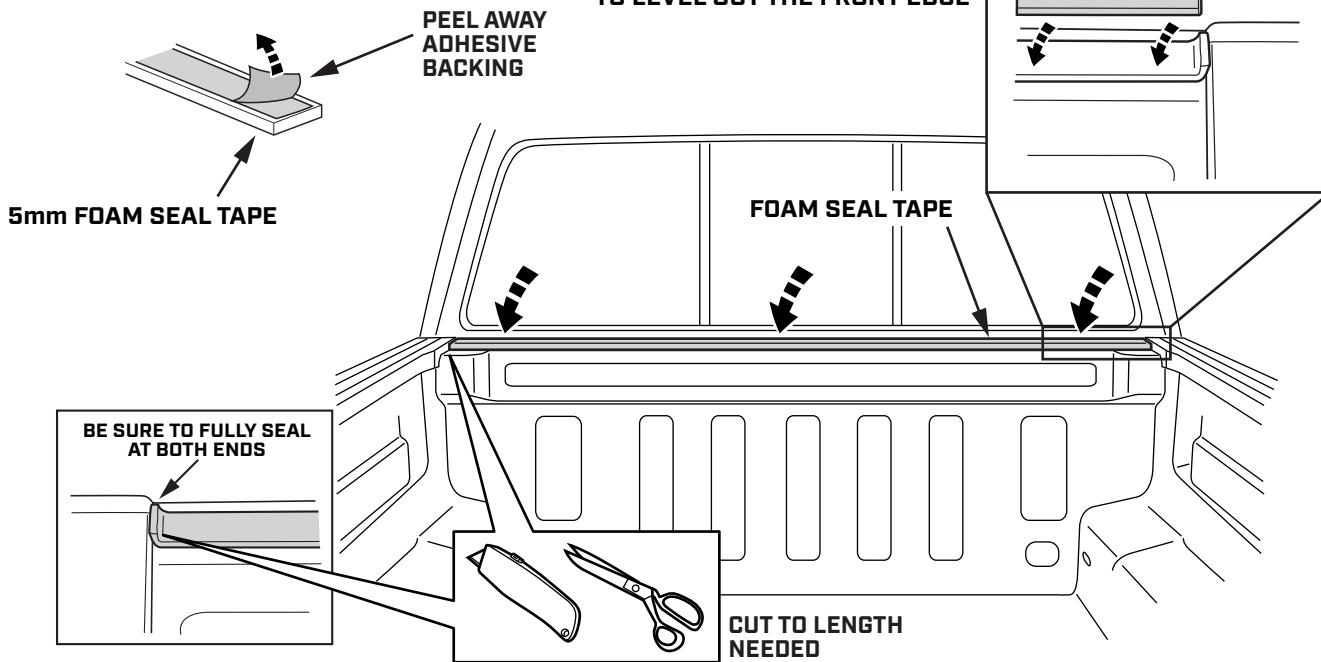

STEP 22

USE A UTILITY KNIFE TO CUT AWAY THE STAKE POCKET IMPRESSIONS LOCATED ON THE FRONT LEFT AND RIGHT CORNERS OF THE TRUCK BED.

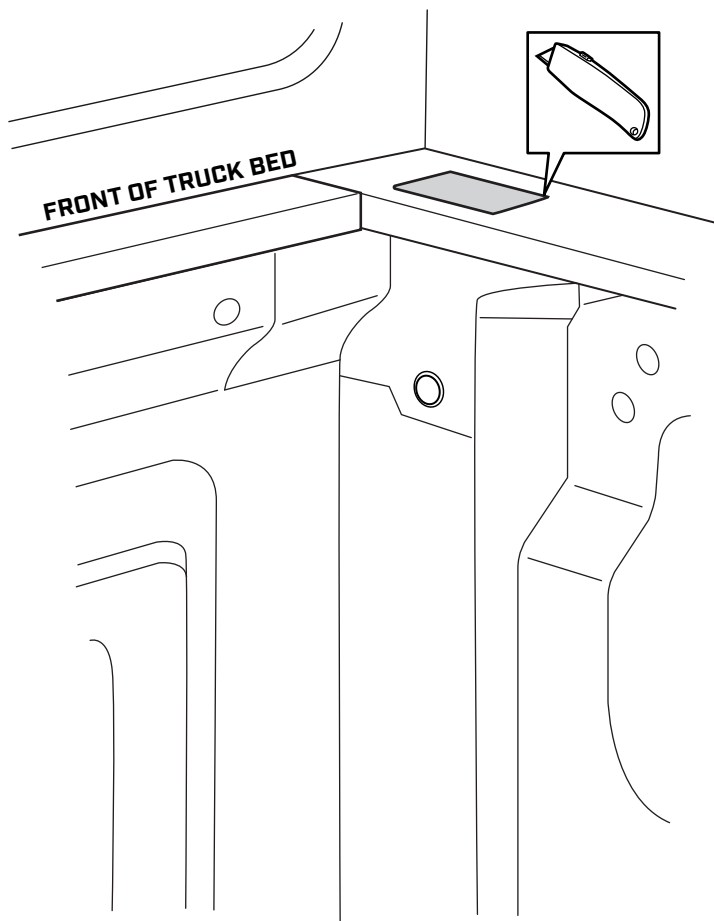

STEP 23

REMOVE THE BLACK PLUG FROM THE SIDE WALL LOCATED UNDER THE TRUCK BED RAILING.

INSERT THE LEFT AND RIGHT FRONT MOUNTING BRACKETS INTO THE OPENINGS ON THE TRUCK BED RAILS.

USING A 6MM HEX SOCKET, TIGHTEN MOUNTING BRACKETS TO THE TRUCK BED WITH M10 BUTTON HEAD BOLT, M10 LOCK WASHER, AND M10 FENDER WASHER AS SHOWN.

BE SURE MOUNTING BRACKET IS FLUSH WITH TRUCK BED RAIL

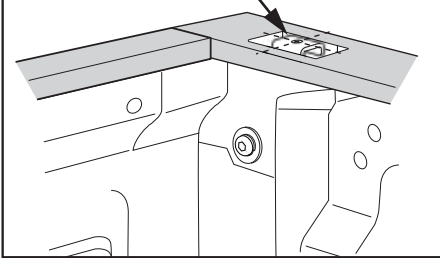

FRONT MOUNTING BRACKET (LONG)

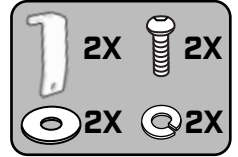

2X
[8.8 ft. lbs]/[12 Nm]

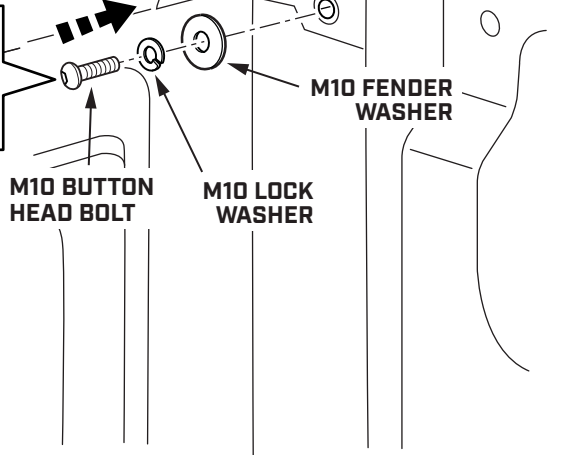
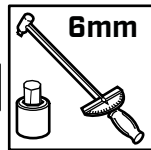

STEP 24

REMOVE THE BLACK PLUG FROM THE SIDE WALL LOCATED UNDER THE TRUCK BED RAILING.

INSERT THE LEFT AND RIGHT REAR MOUNTING BRACKETS INTO THE OPENINGS ON THE TRUCK BED RAILS.

USING A 6MM HEX SOCKET, TIGHTEN MOUNTING BRACKETS TO THE TRUCK BED WITH M10 BUTTON HEAD BOLT, M10 LOCK WASHER, AND M10 FENDER WASHER AS SHOWN.

BE SURE MOUNTING BRACKET IS FLUSH WITH TRUCK BED RAIL

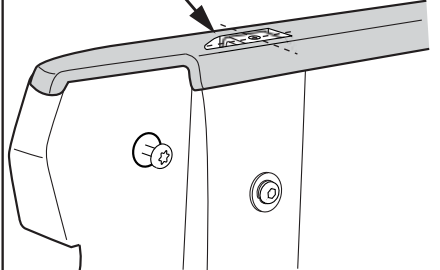

REAR MOUNTING BRACKET (SHORT)

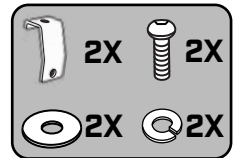

[8.8 ft. lbs]/[12 Nm]



2X

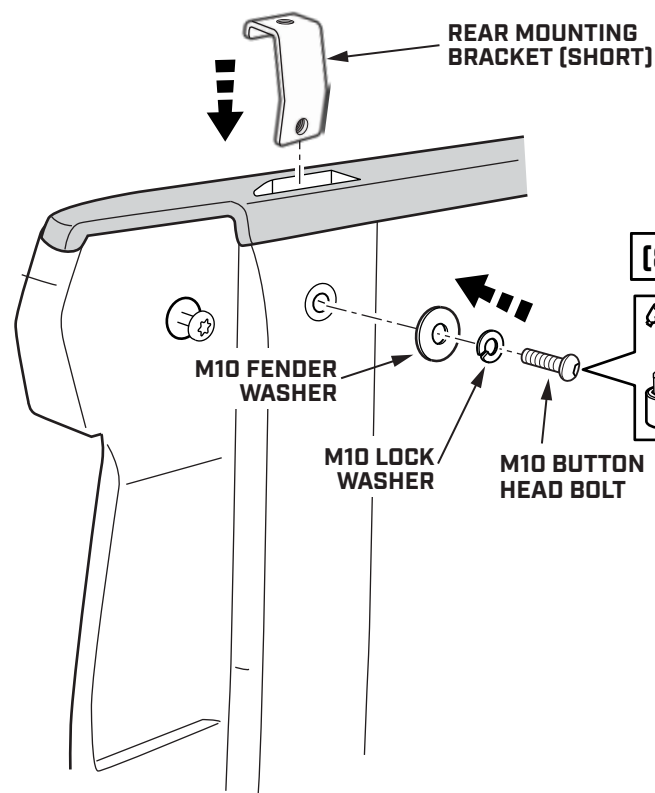

STEP 25

REMOVE THE ADHESIVE BACKING FROM THE THICK RUBBER PAD.

PLACE TWO THICK RUBBER PADS ON EACH SIDE OF ALL FOUR MOUNTING HOLES ALONG THE BOTTOM EDGE OF THE SMARTCAP.

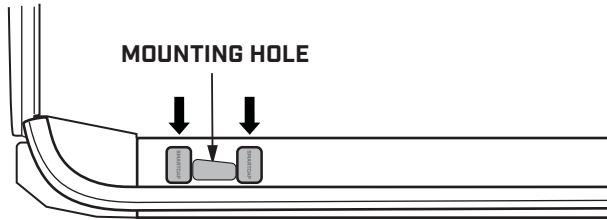

THICK RUBBER PAD

8X

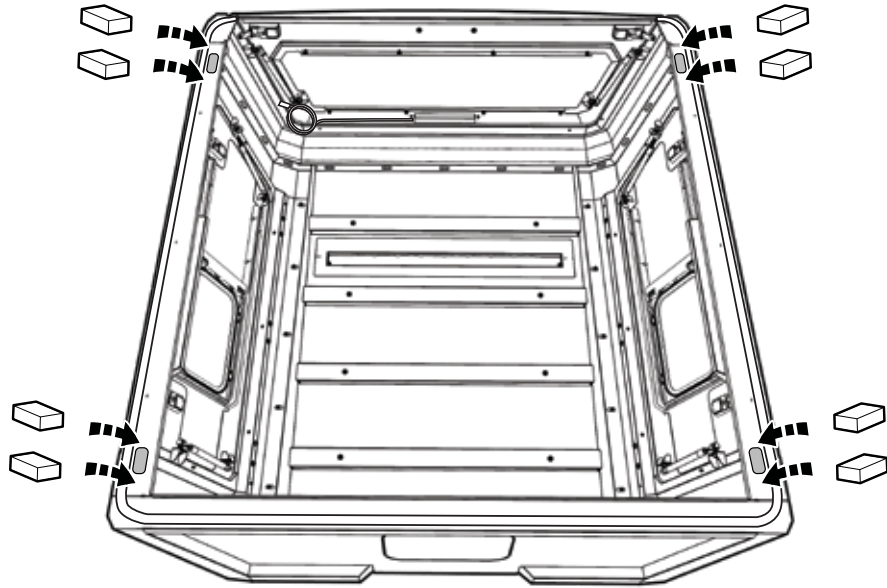
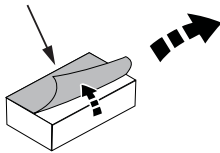

STEP 26

USE 4 PEOPLE TO LIFT THE ASSEMBLED SMARTCAP ONTO THE TRUCK BED.

TO AVOID DAMAGE TO THE D-RUBBER, DO NOT SLIDE THE SMARTCAP INTO PLACE.

4 PERSON JOB

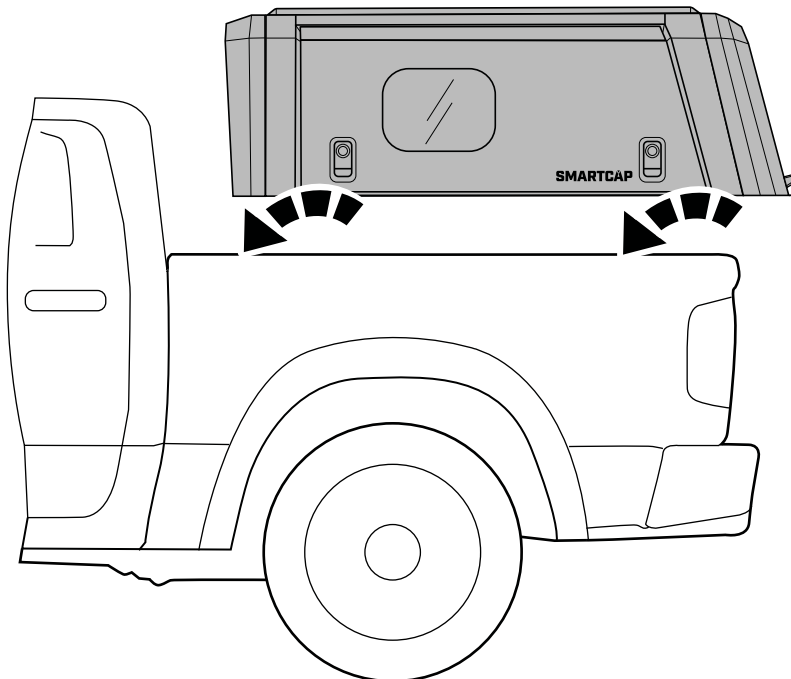

I-SHEET-NA-C2

STEP 27

CHECK THAT THE SMARTCAP IS PROPERLY POSITIONED AND CENTERED ON THE TRUCK BED.



IT'S IMPORTANT THAT THE SMARTCAP IS NOT PUSHED TOO FAR FORWARD, LEAVING A GAP BETWEEN THE SMARTCAP AND THE CAB.

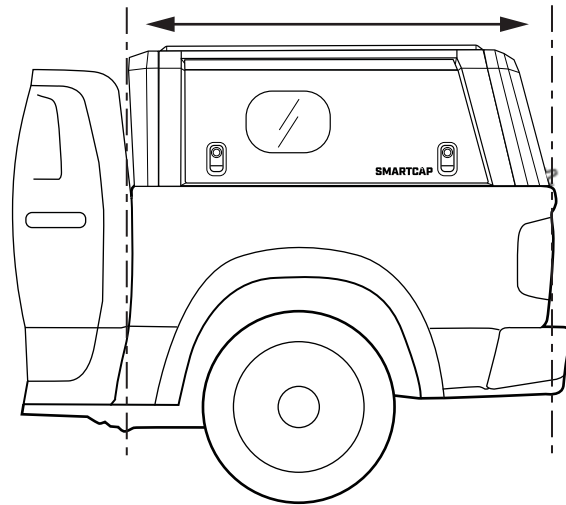
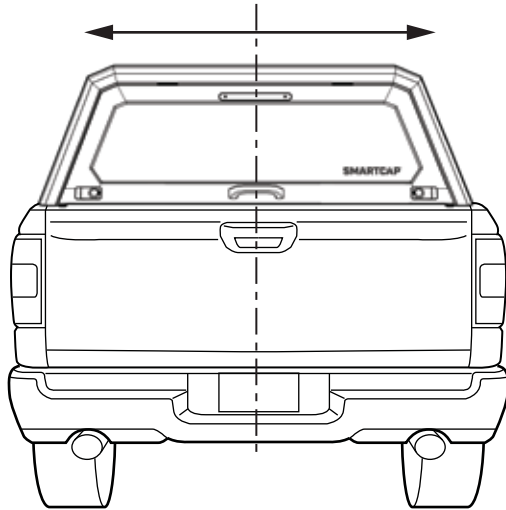

STEP 28

WALK AROUND THE TRUCK BED TO MAKE SURE THE D-RUBBER FITMENT IS CORRECT AND THAT THE RUBBER LIP IS PROPERLY TUCKED UNDERNEATH THE CAP.

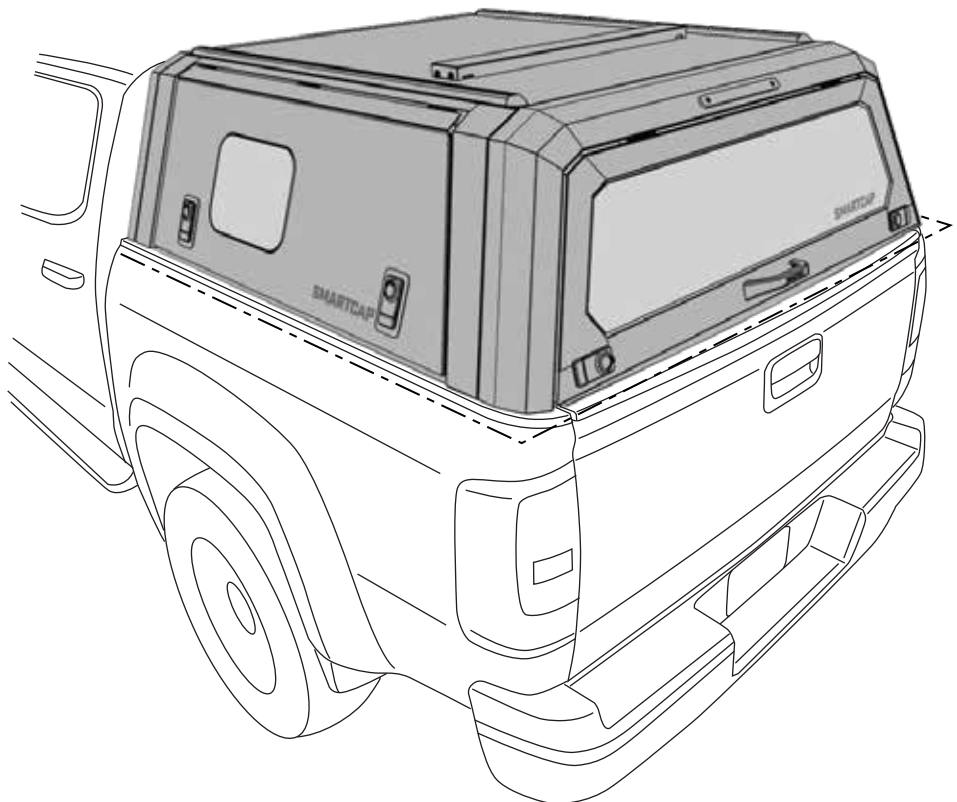

**YOU MAY NOTICE THAT THE SEAL ON THE SLIDING PORTAL WINDOW MIGHT APPEAR WRINKLED. THIS IS DUE TO THE ANTI-SLIP COATING AND IS NOT A CAUSE FOR CONCERN.*

I-SHEET-NA-C2

STEP 29

SECURE THE SMARTCAP TO ALL FOUR MOUNTING BRACKETS ON ALL FOUR CORNERS USING M10 BUTTON HEAD BOLT, M10 LOCK WASHERS AND M10 FENDER WASHER AS SHOWN, HAND TIGHTEN ONLY.

M10 BUTTON HEAD BOLT
M10 LOCK WASHER
M10 FENDER WASHER

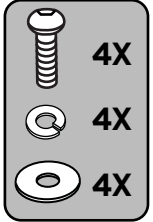
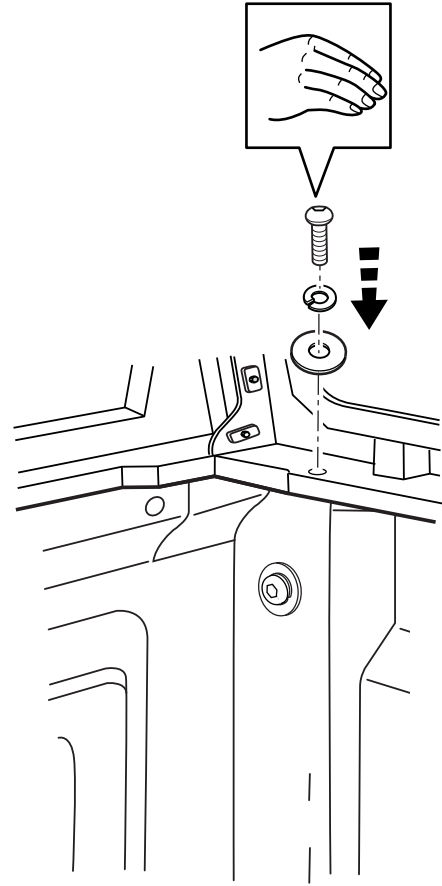
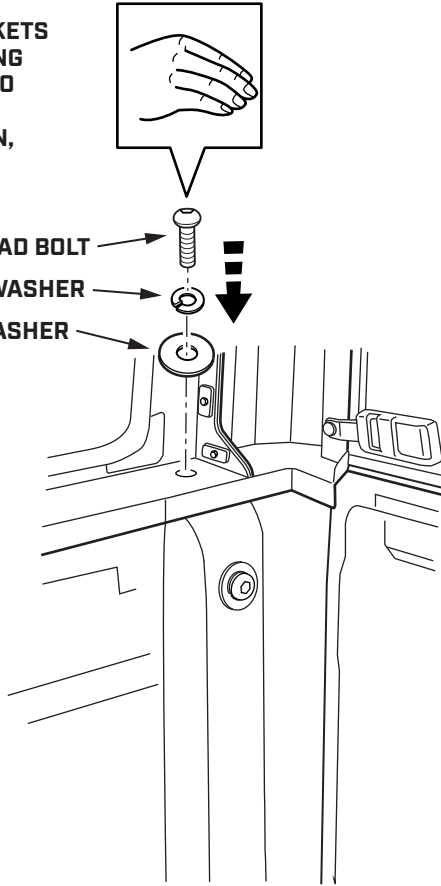

STEP 30

TIGHTEN ALL FOUR M10 BOLTS USING A 6MM HEX SOCKET.

[8.8 ft. lbs]/[12 Nm]

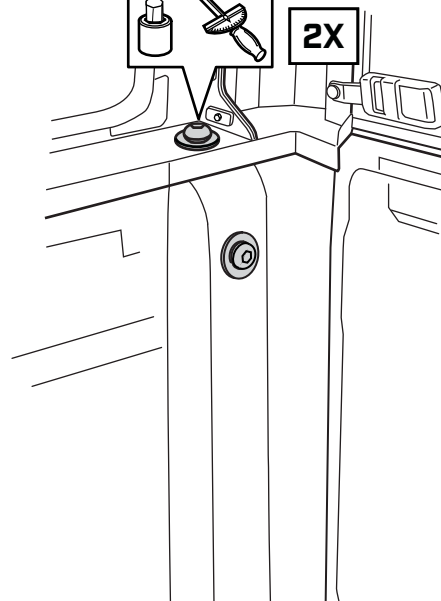

[8.8 ft. lbs]/[12 Nm]

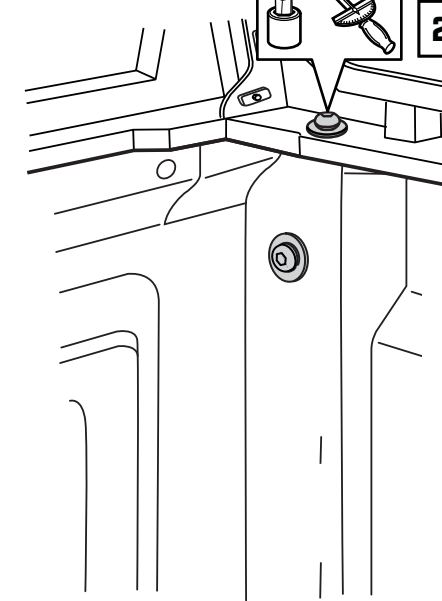

STEP 31

ONCE YOU HAVE FULLY TIGHTENED ALL FASTENERS, YOU WILL NEED TO CONFIRM CORRECT FITMENT OF THE CAP BY CHECKING THE RUBBER SEAL LOCATED ON THE REAR DOOR AS WELL AS THE D-RUBBER.

THE RUBBER SEAL SHOULD MAKE CONTACT WITH THE TAILGATE WITH ZERO GAP BETWEEN THE TWO.

THE D-RUBBER SHOULD MAKE CONTACT WITH THE TAILGATE WITHOUT IMPOSING ON THE OPERATION OF THE TAILGATE.

 THE REAR DOOR RUBBER SEAL SHOULD MAKE CONTACT ALONG THE ENTIRE LENGTH OF THE TAILGATE

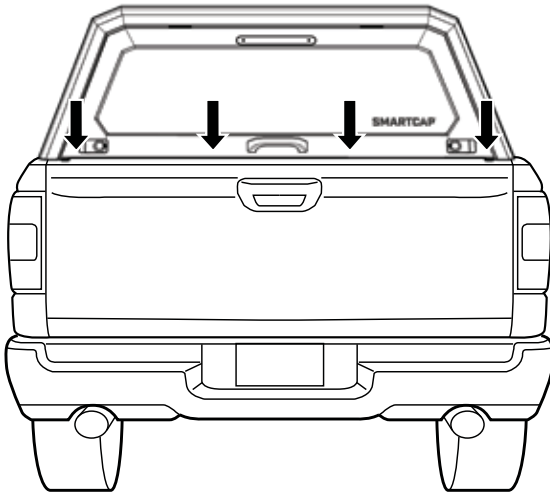

 THERE SHOULD BE 2MM-3MM OF SPACE BETWEEN THE D-RUBBER BASE AND THE D-RUBBER LIP

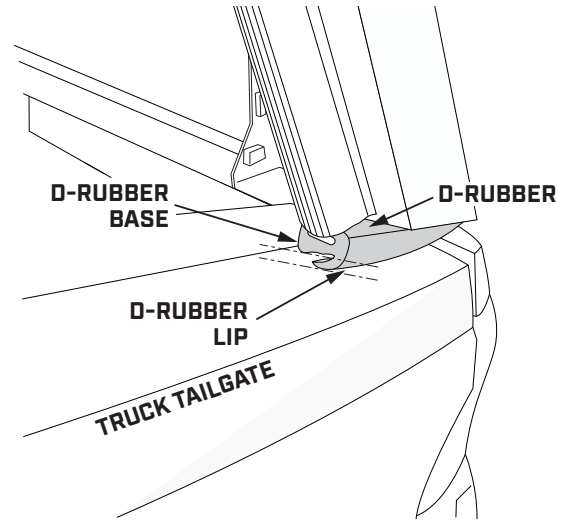

STEP 32

TO ADJUST THE FITMENT OF THE CAP, SLIGHTLY LOOSENING THE M10 BOLTS FOR THE REAR MOUNTING BRACKETS.

IF THERE IS A GAP BETWEEN THE RUBBER SEAL AND THE TAILGATE, GRAB THE CAP NEAR THE ROOF AND FIRMLY PRESS DOWN ON THE SMARTCAP. WHILE PRESSING DOWNWARDS, TIGHTEN THE M10 BOLTS TO THE REQUIRED TORQUE SPEC OF [8.8 ft. lbs]/[12 Nm].

IF THE TAILGATE IS DIFFICULT TO OPEN, GRAB THE CAP NEAR THE ROOF AND FIRMLY PUSH THE CAP UPWARDS. WHILE PUSHING UPWARDS, TIGHTEN THE M10 BOLTS TO THE REQUIRED TORQUE SPEC OF [8.8 ft. lbs]/[12 Nm].

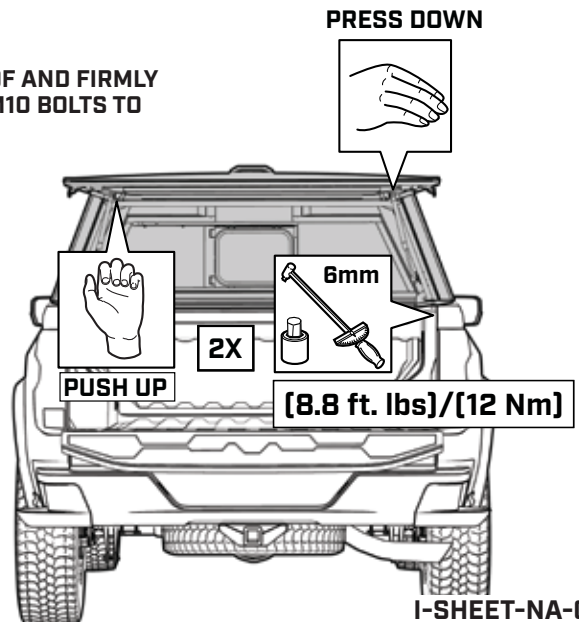
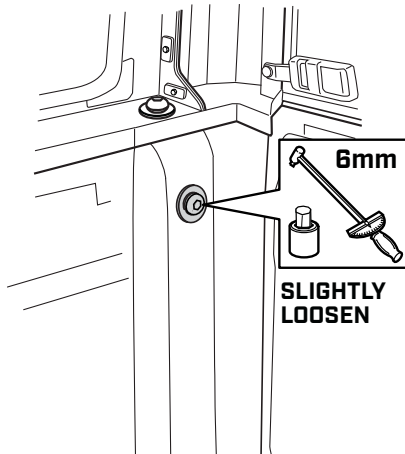

I-SHEET-NA-C2

THIRD BRAKE LIGHT HARDWARE



IMPORTANT

- ▼ BE SURE THE VEHICLE IS TURNED OFF FOR THIS INSTALLATION.
- ▼ READ THROUGH THE ENTIRE PROCEDURE BEFORE STARTING AND FOLLOW THE STEPS CAREFULLY TO ENSURE THE THIRD BRAKE LIGHT WILL FUNCTION PROPERLY.
- ▼ USE A TEST LIGHT TO CHECK FOR SUCCESSFUL INSTALLATION.

STEP 33-38

GM COLORADO (2023)

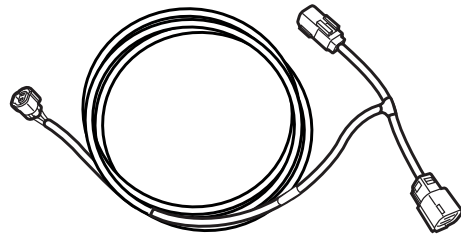

1X

STEP 39-50

GM CANYON (2023)

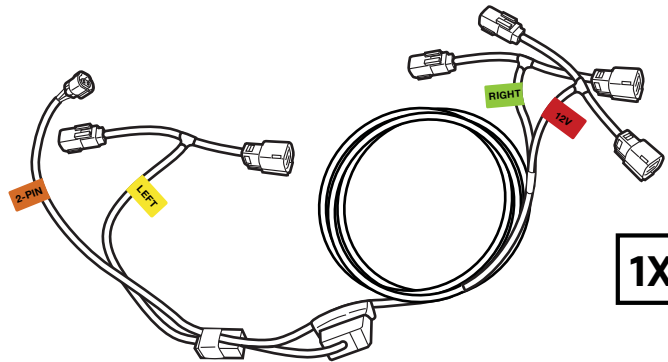

1X

STEP 33

UNTIE THE THIRD BRAKE LIGHT EXTENSION HARNESS FROM WHERE IT IS ATTACHED TO THE SMARTCAP AT THE LEFT REAR CORNER.

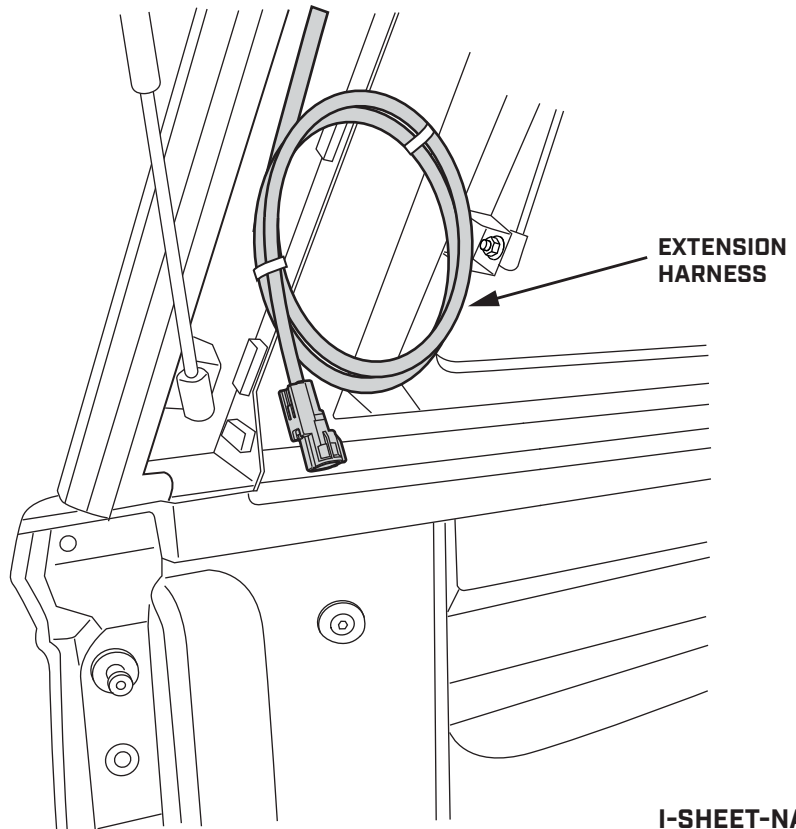

I-SHEET-NA-C2

STEP 34

ROUTE THE THIRD BRAKE LIGHT EXTENSION HARNESS IN THROUGH THE BED RAIL OPENING AND DOWN TOWARDS THE REAR BUMPER.

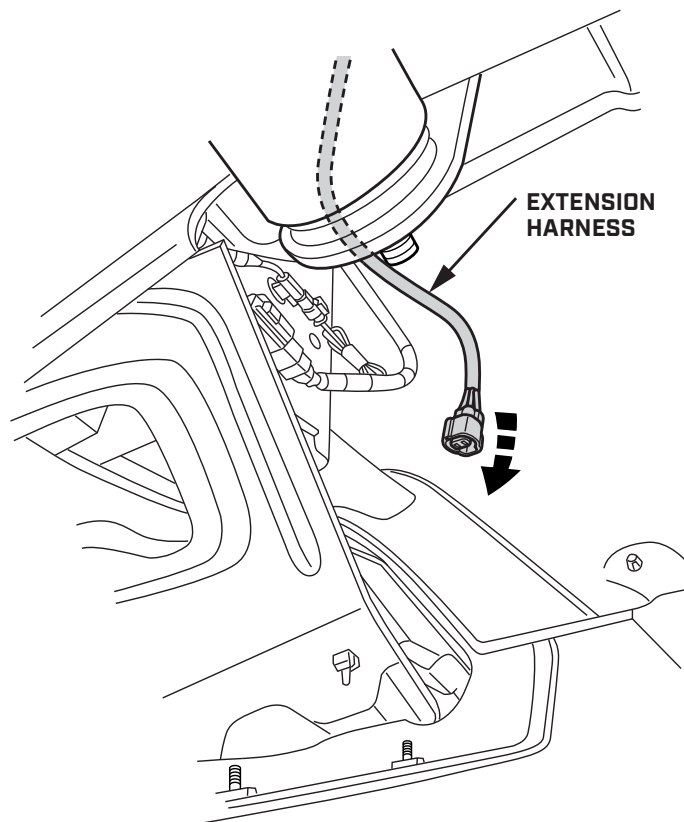
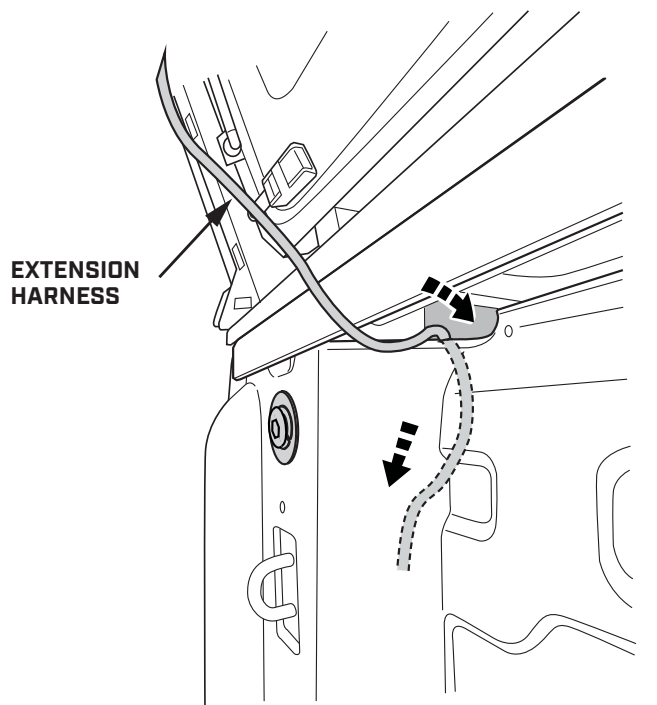

STEP 35

FROM BELOW, PLUG THE CONNECTOR FROM THE EXTENSION HARNESS INTO THE 2-PIN CONNECTOR OF THE T-HARNESS AS SHOWN.

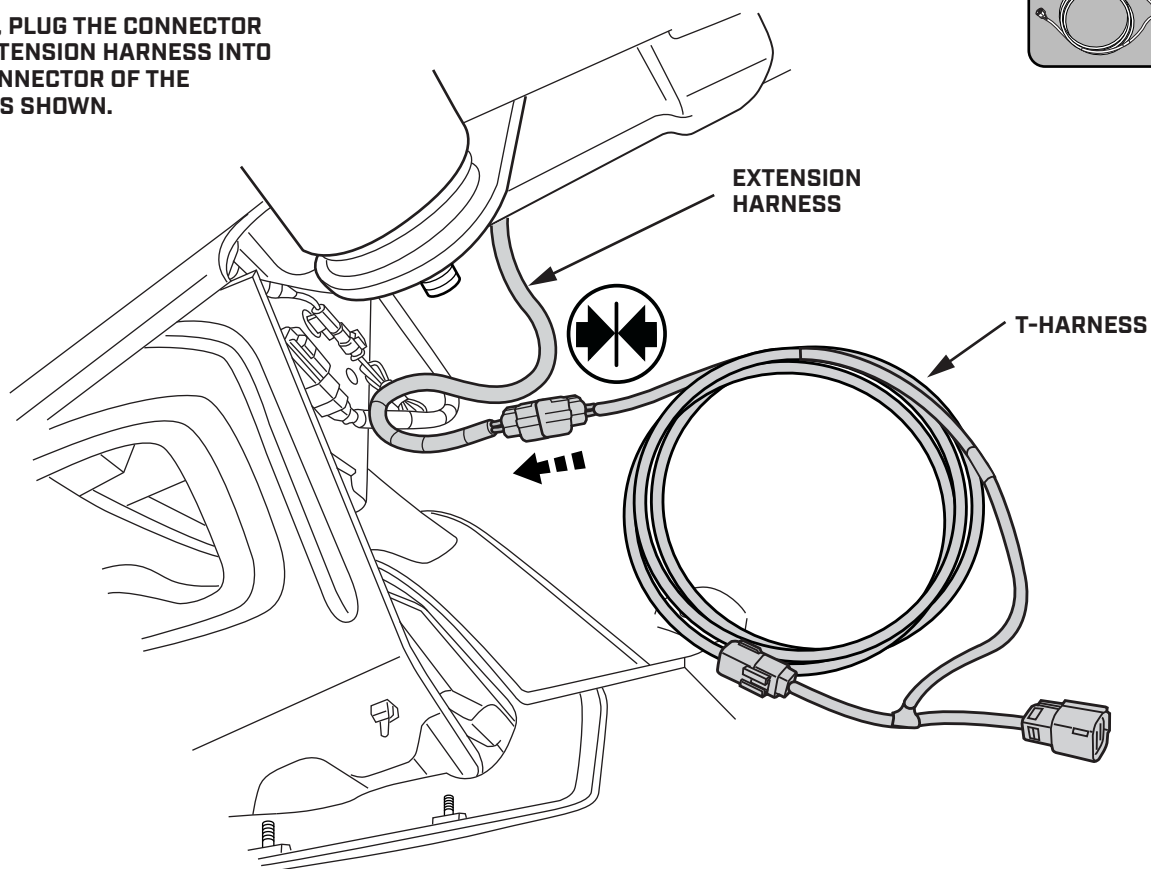
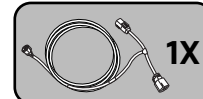

I-SHEET-NA-C2

STEP 36

LOCATE THE BLACK 6-PIN VEHICLE CONNECTOR, CLOSE TO THE DRIVER SIDE TAILLIGHT. PULL BACK ON THE RED TAB, PRESS DOWN ON THE BLACK TAB, AND PULL THE CONNECTORS APART.

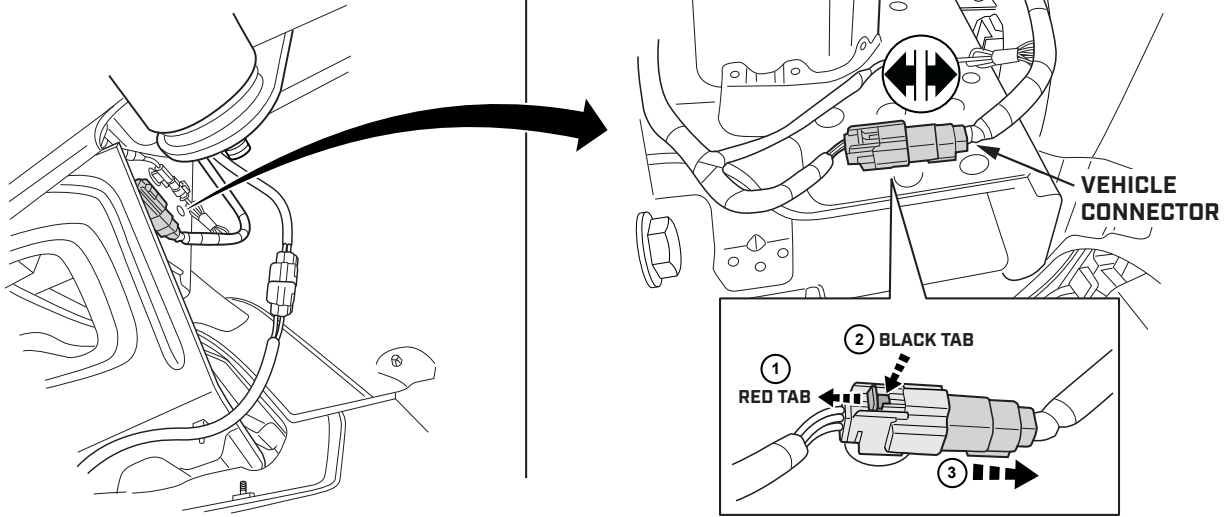

STEP 37

CONNECT THE T-HARNESS FEMALE CONNECTOR TO THE VEHICLE HARNESS MALE CONNECTOR.

CONNECT THE T-HARNESS MALE CONNECTOR TO THE VEHICLE HARNESS FEMALE CONNECTOR.

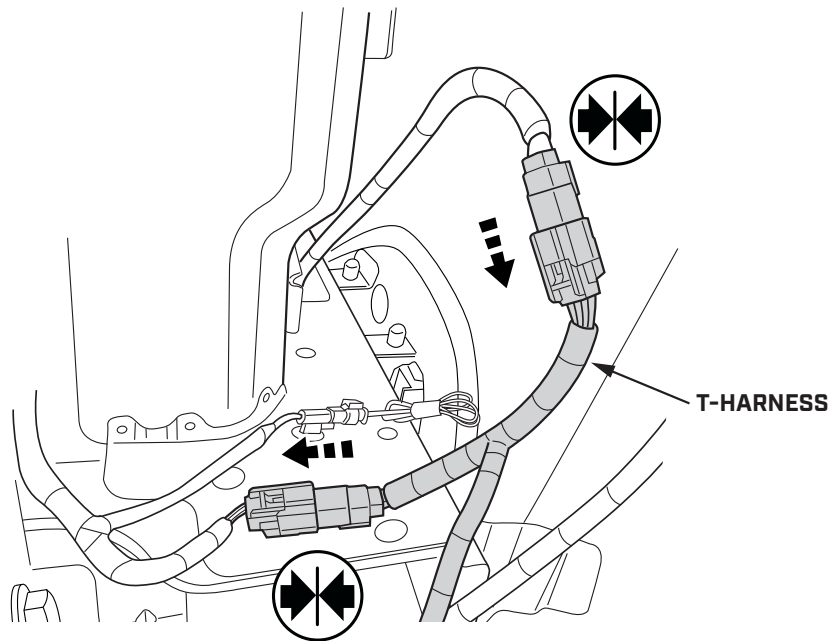

STEP 38



TEST YOUR BRAKE LIGHTS & TURN SIGNALS

- ▼ START THE TRUCK. SOME MODELS MAY TAKE UP TO 30 SECONDS FOR THE VEHICLE TO DETECT THE NEW CONNECTION.
- ▼ CHECK THE BRAKE LIGHTS AND TURN SIGNALS TO BE SURE THEY ARE FUNCTIONING PROPERLY.
- ▼ ONCE YOU HAVE CONFIRMED THAT THE LIGHTS ARE WORKING CORRECTLY, SECURE THE HARNESS WITH CABLE TIES.
- ▼ BE SURE NOT TO INTERFERE WITH ANY MOVING PARTS ON THE VEHICLE.

STEP 39

UNTIE THE THIRD BRAKE LIGHT EXTENSION HARNESS FROM WHERE IT IS ATTACHED TO THE SMARTCAP AT THE LEFT REAR CORNER.

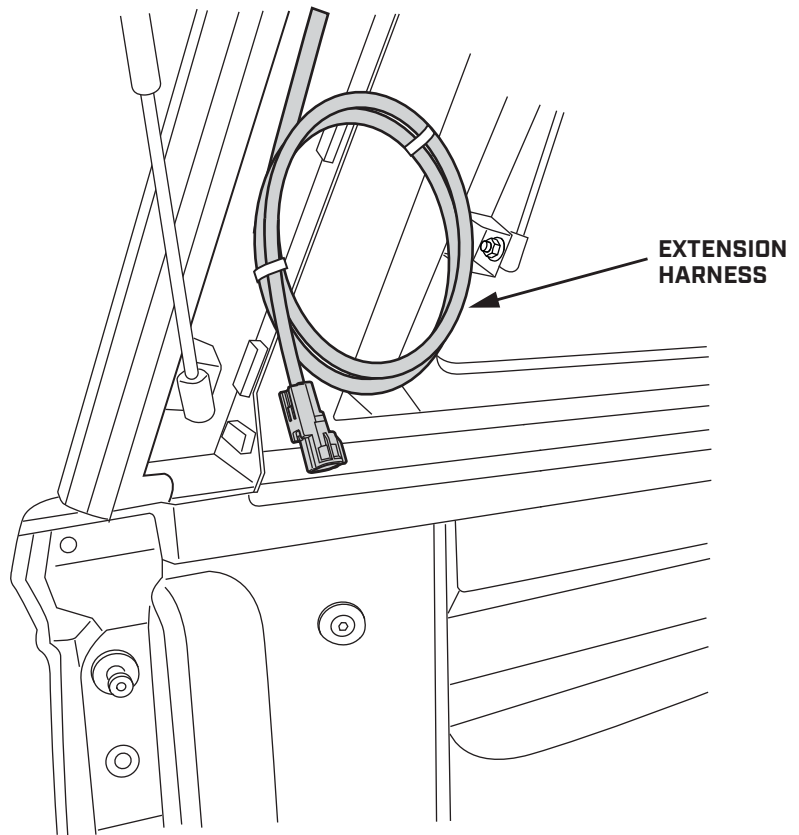

STEP 40

ROUTE THE THIRD BRAKE LIGHT EXTENSION HARNESS IN THROUGH THE BED RAIL OPENING AND DOWN TOWARDS THE REAR BUMPER.

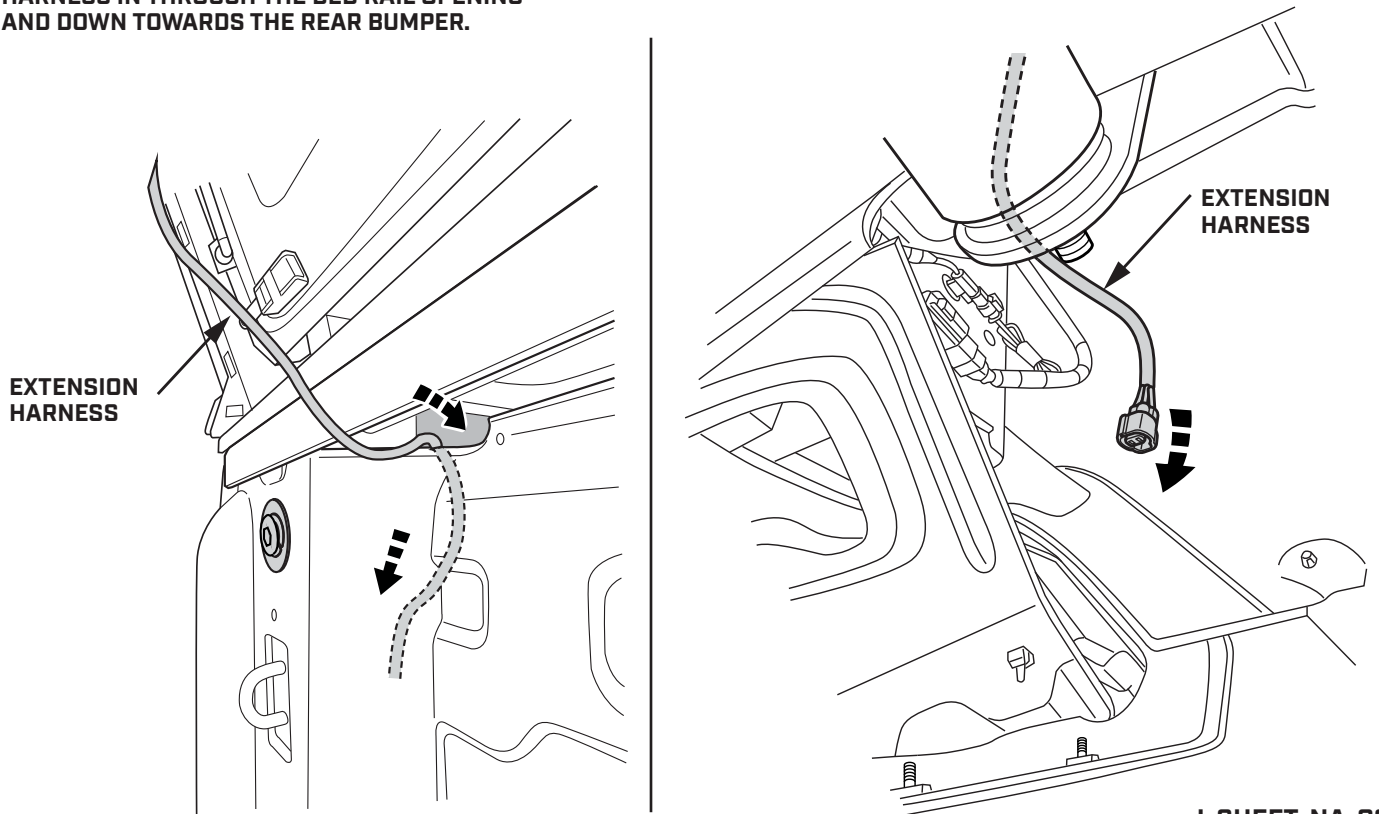

I-SHEET-NA-C2

STEP 41

FROM BELOW, PLUG THE CONNECTOR FROM THE EXTENSION HARNESS INTO THE 2-PIN CONNECTOR OF THE T-HARNESS AS SHOWN.

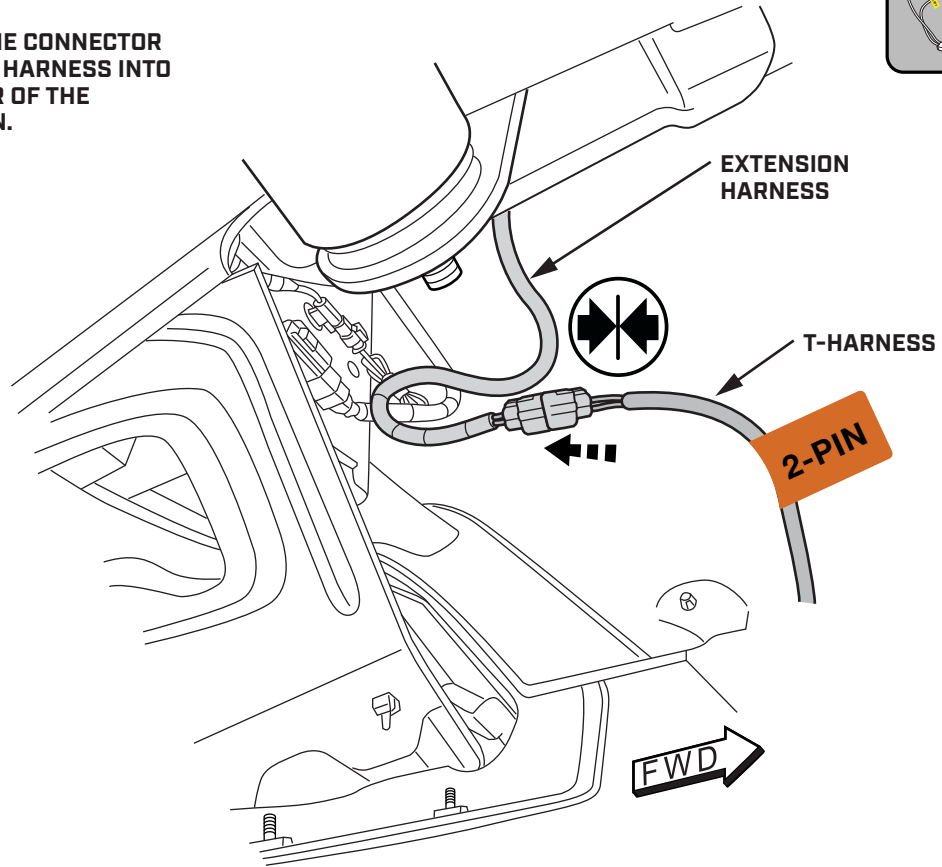
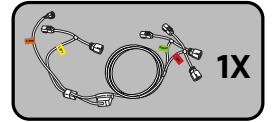

STEP 42

LOCATE THE BLACK 6-PIN VEHICLE CONNECTOR, CLOSE TO THE DRIVER SIDE TAILLIGHT. PULL BACK ON THE RED TAB, PRESS DOWN ON THE BLACK TAB, AND PULL THE CONNECTORS APART.

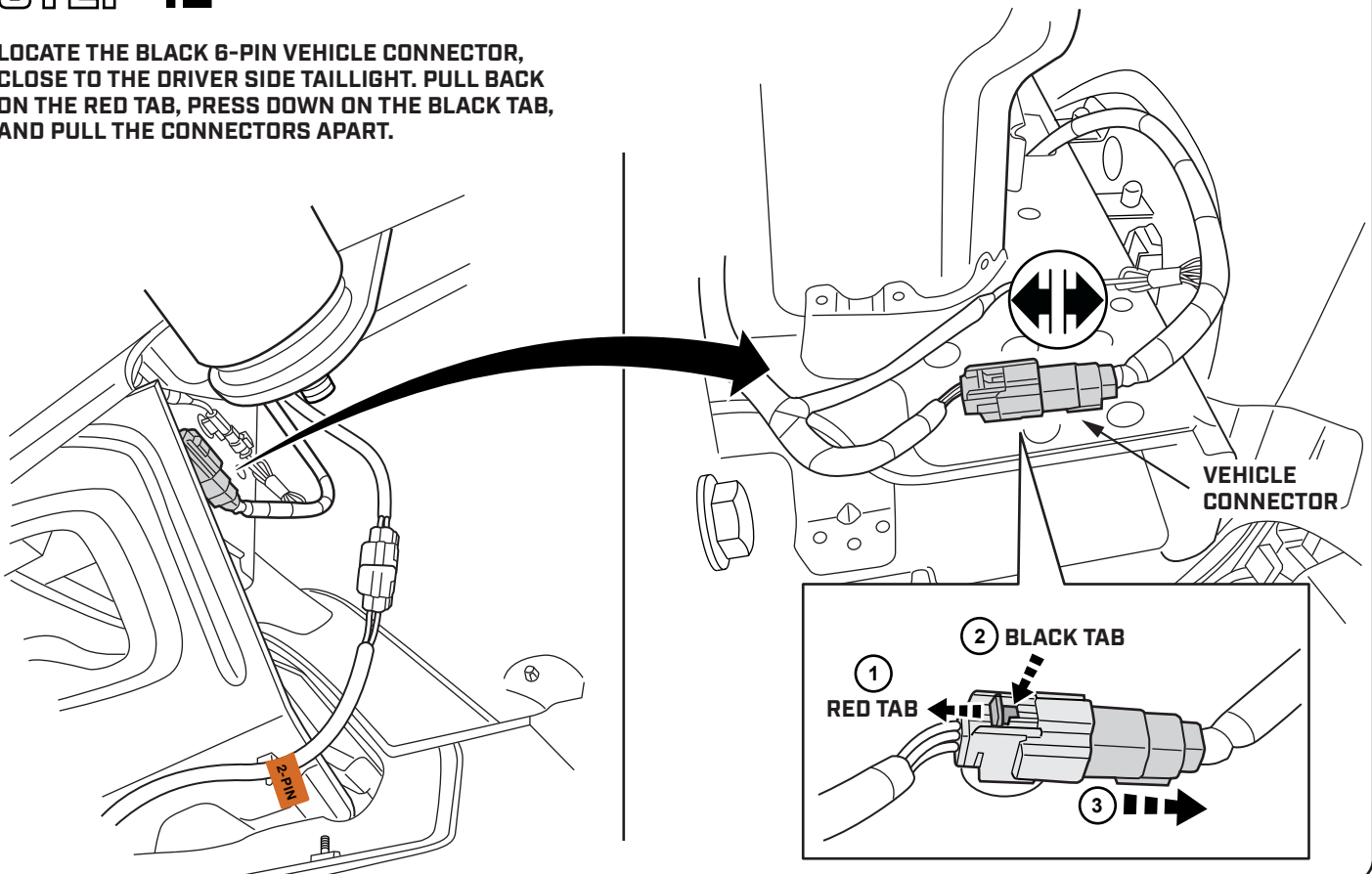

STEP 43

USING THE END OF THE T-HARNESS LABELED "LEFT", CONNECT THE T-HARNESS FEMALE CONNECTOR TO THE VEHICLE HARNESS MALE CONNECTOR.

CONNECT THE T-HARNESS MALE CONNECTOR TO THE VEHICLE HARNESS FEMALE CONNECTOR.

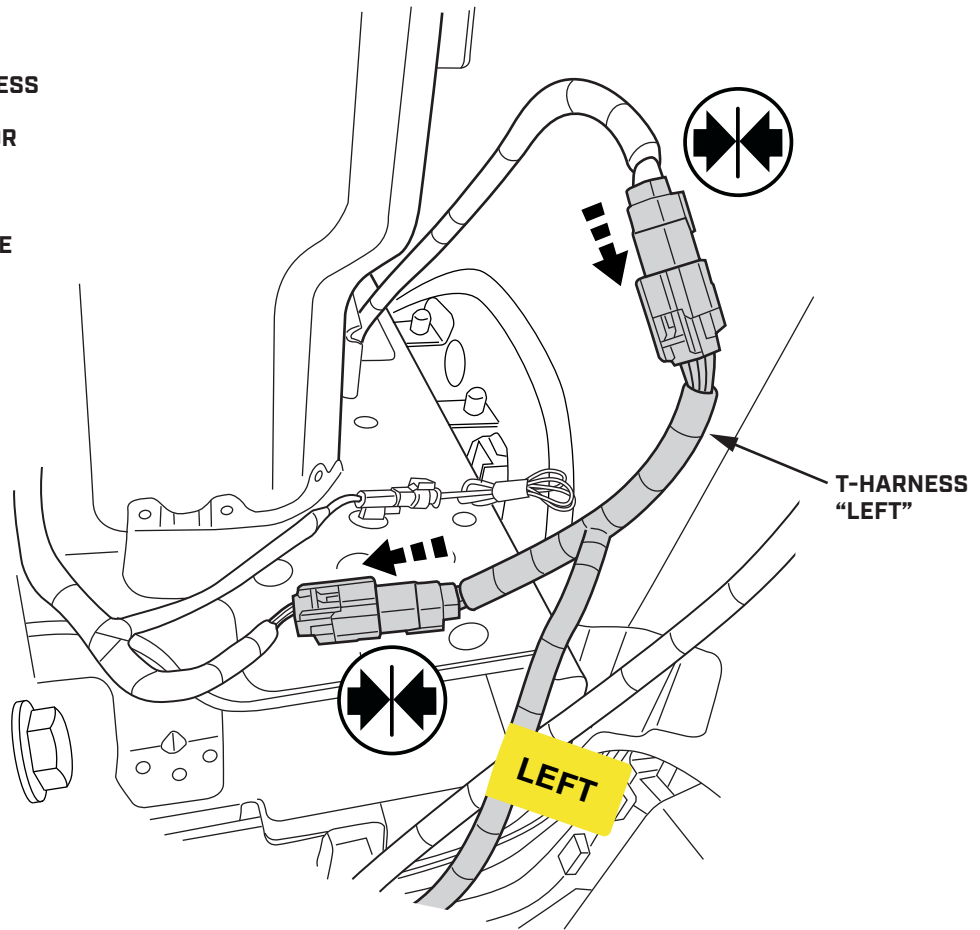

STEP 44

BEGIN ROUTING THE ENDS OF THE T-HARNESS LABELED "RIGHT" AND "12V" TOWARDS THE RIGHT SIDE OF THE TRUCK. ROUTE THE HARNESS ABOVE THE CHASSIS AS SHOWN.

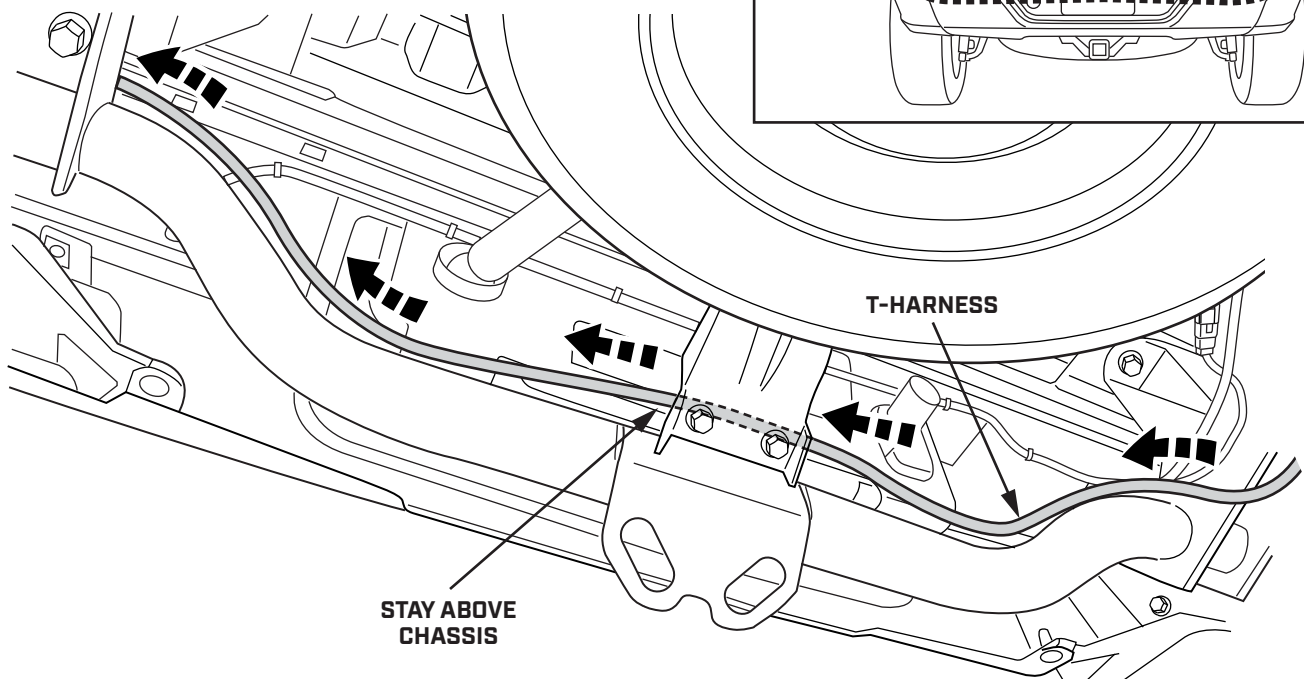

STEP 45

CONTINUE ROUTING THE HARNESS TOWARDS THE TAILPIPE.

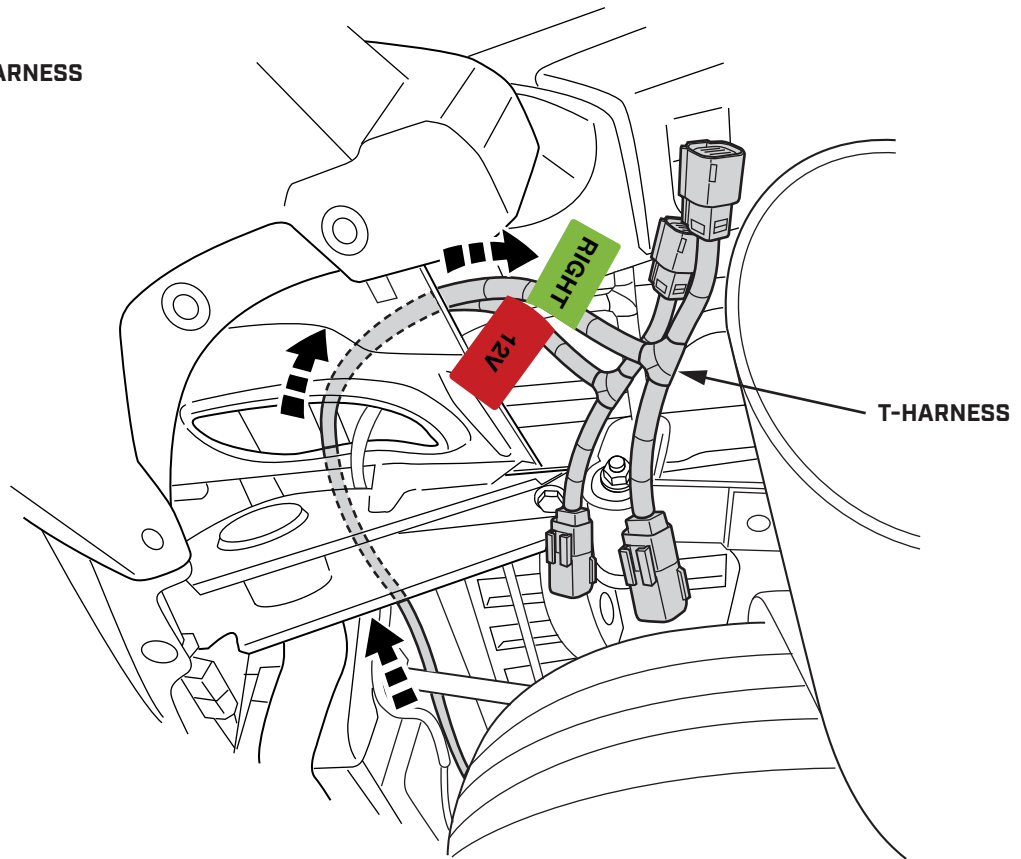

STEP 46

LOCATE THE 6-PIN VEHICLE CONNECTOR ON THE PASSENGER SIDE OF THE TRUCK, CLOSE TO THE TAILLIGHT. PULL BACK ON THE RED TAB, PRESS DOWN ON THE BLACK TAB, AND PULL THE CONNECTORS APART.

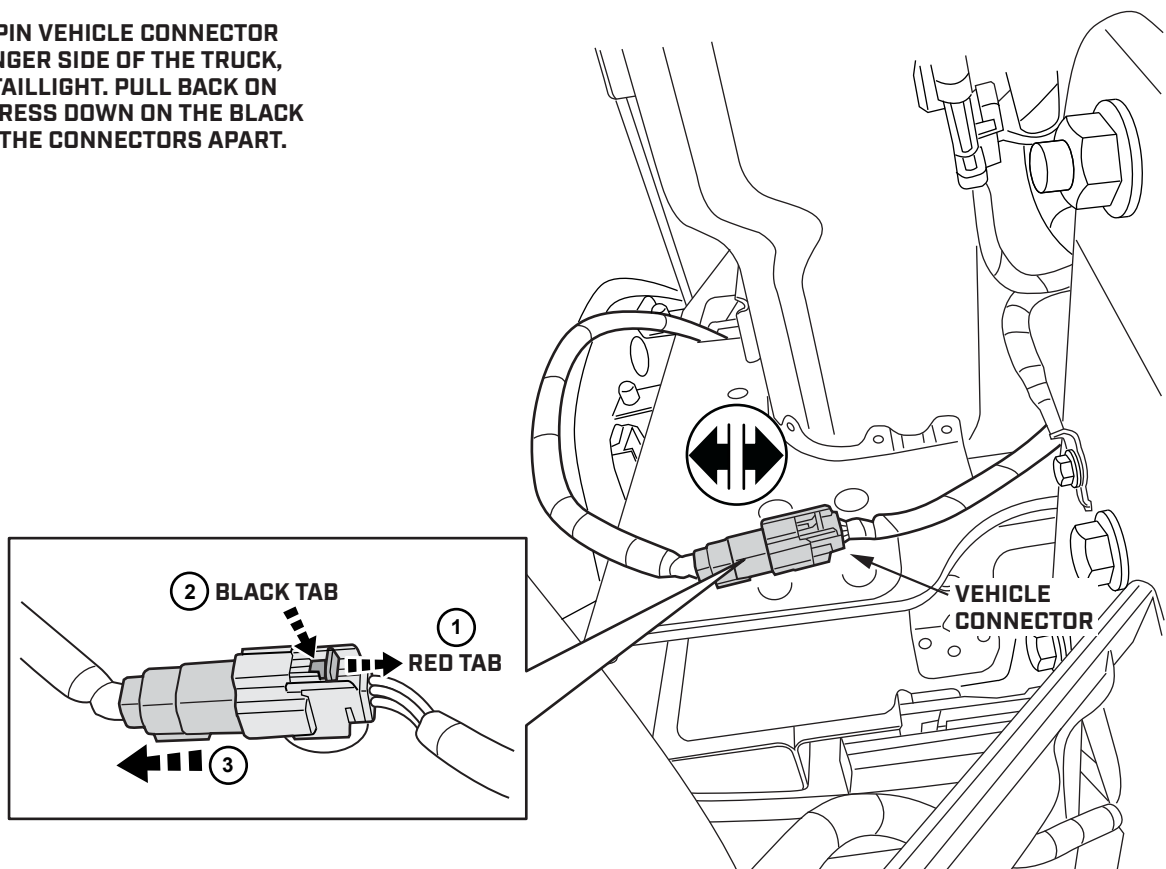

STEP 47

USING THE END OF THE T-HARNESS LABELED "RIGHT", CONNECT THE T-HARNESS FEMALE CONNECTOR TO THE VEHICLE HARNESS MALE CONNECTOR.

CONNECT THE T-HARNESS MALE CONNECTOR TO THE VEHICLE HARNESS FEMALE CONNECTOR.

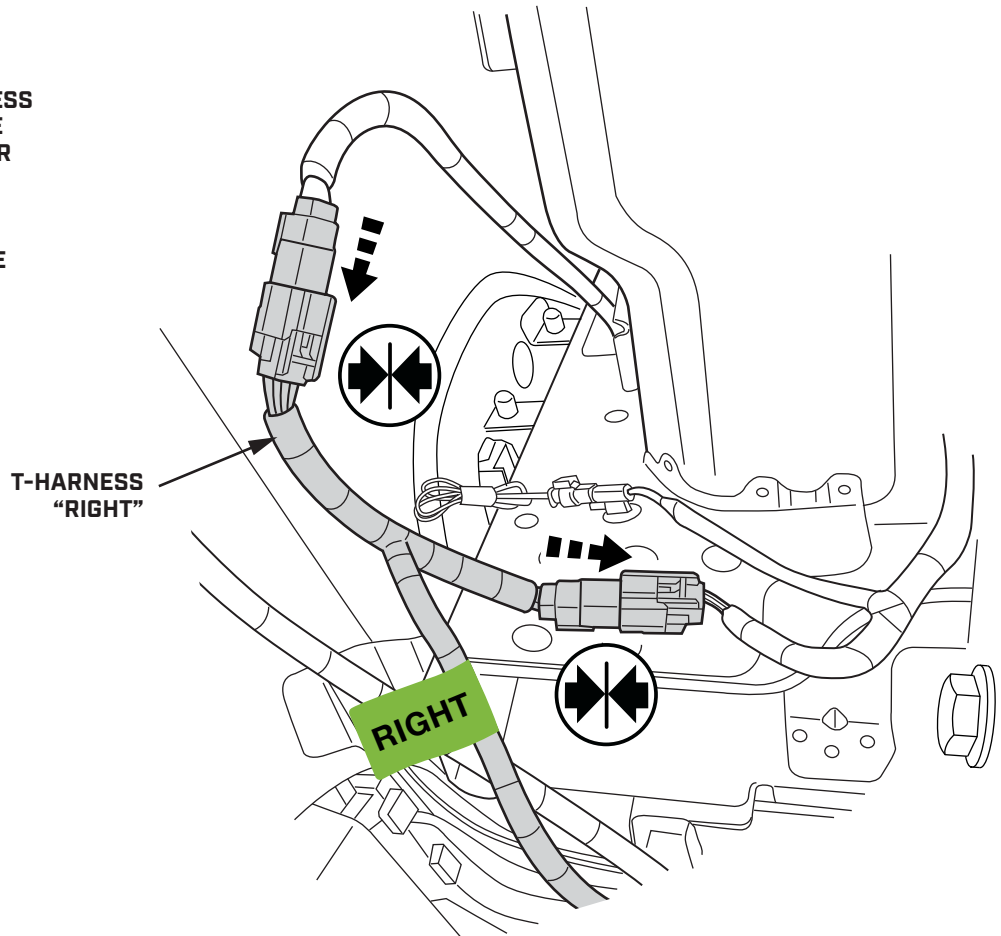

STEP 48

LOCATE THE 6-PIN VEHICLE CONNECTOR ON THE ORANGE AUXILIARY CABLE. PULL BACK ON THE RED TAB, PRESS DOWN ON THE BLACK TAB, AND PULL THE CONNECTORS APART.

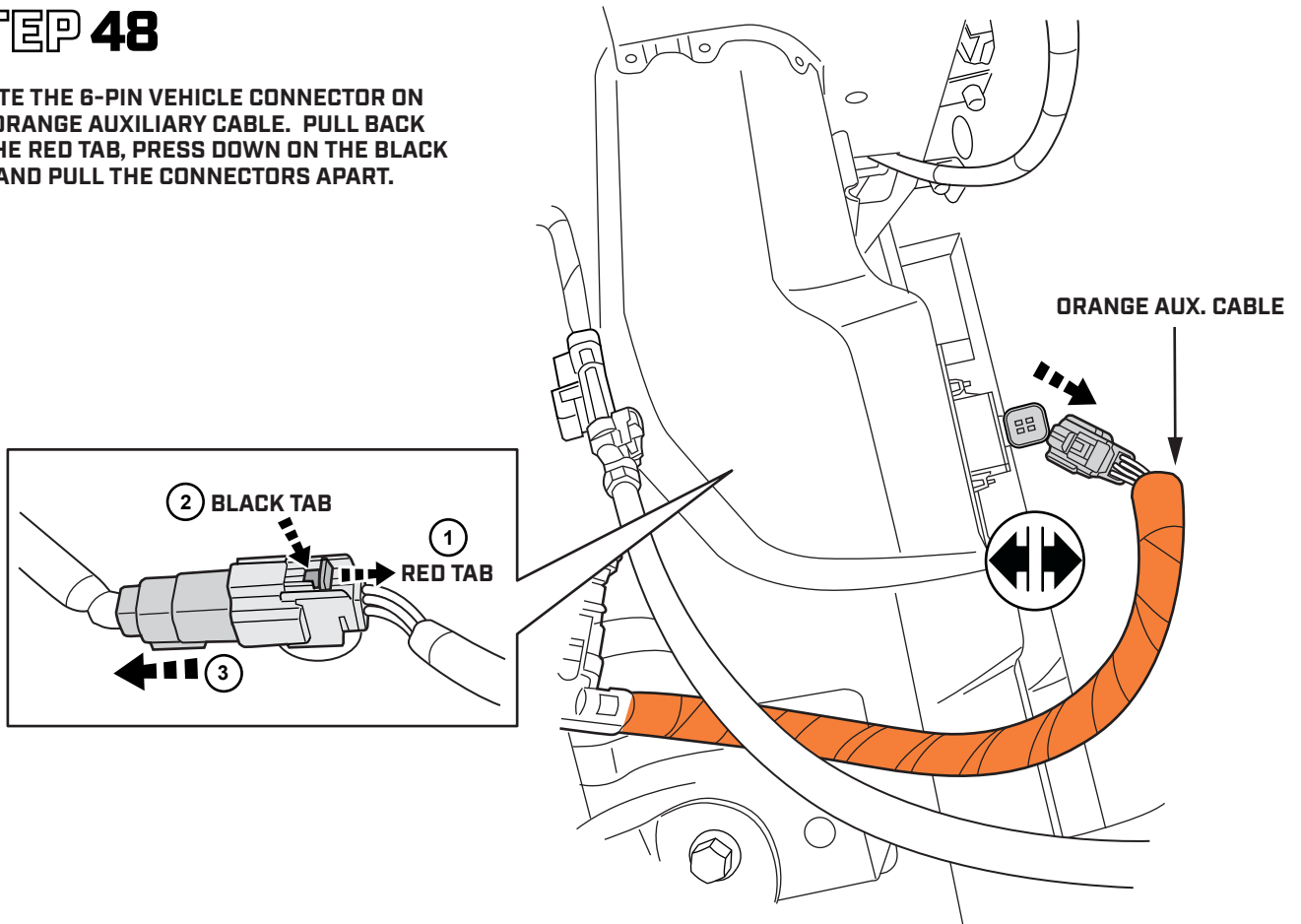

STEP 49

USING THE END OF THE T-HARNESS LABELED "12V", CONNECT THE T-HARNESS FEMALE CONNECTOR TO THE VEHICLE HARNESS MALE CONNECTOR.

CONNECT THE T-HARNESS MALE CONNECTOR TO THE VEHICLE HARNESS FEMALE CONNECTOR.

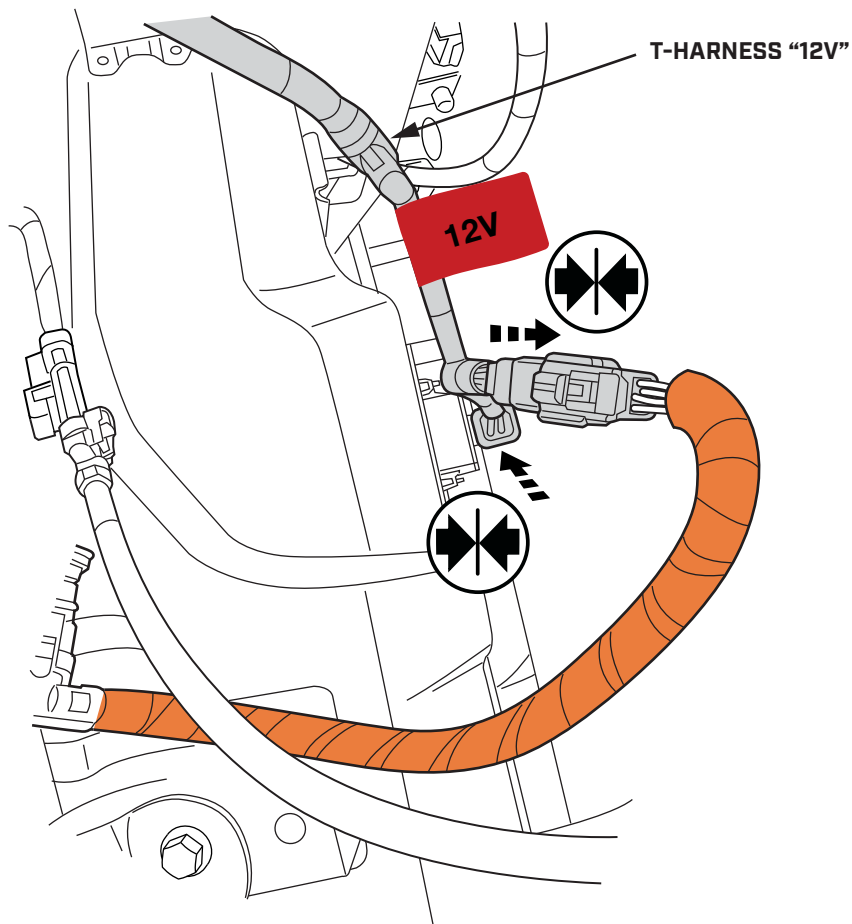

STEP 50



TEST YOUR BRAKE LIGHTS & TURN SIGNALS

- ▼ START THE TRUCK. SOME MODELS MAY TAKE UP TO 30 SECONDS FOR THE VEHICLE TO DETECT THE NEW CONNECTION.
- ▼ CHECK THE BRAKE LIGHTS AND TURN SIGNALS TO BE SURE THEY ARE FUNCTIONING PROPERLY.
- ▼ ONCE YOU HAVE CONFIRMED THAT THE LIGHTS ARE WORKING CORRECTLY, SECURE THE HARNESS WITH CABLE TIES.
- ▼ BE SURE NOT TO INTERFERE WITH ANY MOVING PARTS ON THE VEHICLE.



SMARTCAP[®]

THANKS FOR YOUR PURCHASE.
PLEASE LET US KNOW IF YOU HAVE ANY QUESTIONS.

SMARTCAP.COM - SUPPORT.NA@SMARTCAP.COM - NORTH AMERICA

